

## Fire Detection And Prevention in Electric Vehicles (Ev)

Durgesh Kulkarni<sup>1,\*</sup>, Snehal Phadol<sup>2</sup>, Sarika Kothare<sup>3</sup>, S.S. Lokhande<sup>4</sup>

### Abstract

*This abstract presents a novel approach to fire prevention and detection in electric vehicles (EVs), highlighting the challenges posed by their high-voltage battery systems. The proposed system integrates advanced fire detection technology, such as infrared sensors and thermal imaging, with automatic gas release mechanisms triggered upon fire detection to manage the temperature of the electric engine and suppress fires effectively. The chosen gas serves a dual purpose of reducing oxygen levels to suppress fires and maintaining the engine's temperature within safe limits. While offering benefits like increased fire safety and reduced damage, challenges related to gas selection, release mechanisms, and system integration require careful consideration for ensuring overall safety and reliability. Despite these challenges, the development of such an advanced system signifies a significant advancement in enhancing the safety of EVs, emphasizing the importance of maintaining the electric engine's required temperature during fire incidents for the future of EV safety.*

**Keywords:** EV: Electric Vehicle, BMS: Battery Management System , , ECU: Electronic Control Unit, Li-ion: Lithium-ion, MQ: Methane/CH<sub>4</sub> Quality Sensor

### INTRODUCTION

The motor vehicle sector has undergone a revolution with the widespread adoption of electric vehicles (EVs), which provide environmentally friendly substitutes for conventional cars with gasoline engines.. However, with the surge in EV usage, concerns regarding the safety of high-energy density battery packs have become paramount. Thermal incidents pose a significant risk in EVs due to the inherent properties of lithium-ion batteries, necessitating robust safety measures to mitigate potential hazards effectively. This project aims to address these concerns by pioneering a novel approach that integrates specially designed cylinders containing inert gases to manage oxygen levels during thermal events in electric vehicles [1].

#### \*Author for Correspondence

Durgesh Kulkarni  
E-mail: [durgeshkulkarni.scoe.entc@gmail.com](mailto:durgeshkulkarni.scoe.entc@gmail.com)

<sup>1-3</sup>Student, Department of Electronics & Telecommunication, Sinhgad College of Engineering, Savitribai Phule University, Pune, Maharashtra, India

<sup>4</sup>Professor, Department of Electronics & Telecommunication, Sinhgad College of Engineering, Savitribai Phule University, Pune, Maharashtra, India

Received Date: April 25, 2024

Accepted Date: May 02, 2024

Published Date: May 24, 2024

**Citation:** Durgesh Kulkarni, Snehal Phadol, Sarika Kothare, S.S. Lokhande. Fire Detection And Prevention in Electric Vehicles (Ev). Journal of Automobile Engineering and Applications. 2024; 11(1): 26–31p.

The critical need for enhanced safety measures in EVs stems from the unique challenges associated with high-energy density battery packs. Lithium-ion batteries, while efficient in powering electric vehicles, are susceptible to thermal runaway events, where internal temperatures escalate rapidly, leading to fire or explosion. Such incidents not only jeopardize the vehicle and its occupants but also pose a threat to surrounding infrastructure and the environment. Therefore, devising innovative solutions to prevent and mitigate thermal incidents is imperative for the widespread acceptance and sustainability of electric transportation.

This research endeavor embarks on exploring the efficacy of integrating inert gases within the electric vehicle architecture to suppress fires and maintain safe operating conditions [2–4]. By conducting extensive experimentation and analysis, various gas compositions and deployment mechanisms are evaluated to ascertain their effectiveness in mitigating thermal incidents. The proposed system operates synergistically with conventional fire detection technology, forming a comprehensive safety framework that encompasses both prevention and detection aspects.

The core principle underlying the advanced fire prevention and detection system lies in the utilization of state-of-the-art technologies to swiftly identify and respond to potential fire hazards. Infrared sensors and thermal imaging techniques are employed to monitor the electric vehicle's engine compartment continuously. Upon detecting a fire, a specially designed cylinder equipped with a valve releases a carefully chosen gas onto the electric engine, serving a dual purpose of fire suppression and temperature regulation. The selection of the gas composition and the precision of its release mechanism are paramount in ensuring the effectiveness of the system while minimizing the risk of damage to the electric engine.

In summary, the development of an advanced fire prevention and detection system represents a significant milestone in enhancing the safety of electric vehicles. By integrating innovative technologies and methodologies, this research aims to address the critical safety concerns associated with thermal incidents in EVs. Moreover, by focusing on maintaining the electric engine's temperature within safe operating parameters during fire events, this pioneering approach not only safeguards the vehicle and its occupants but also contributes to the overall security of battery-powered transportation systems [5].

## OBJECTIVE

1. The primary objective of this project is to pioneer an innovative fire detection and prevention system for electric vehicles by incorporating an inert gas cylinder that can effectively reduce oxygen levels in the event of a thermal incident.
2. The study aims to evaluate the optimal gas composition, deployment mechanisms, and integration with existing fire detection systems, ultimately enhancing the safety and security of Electric Vehicles.
3. By pioneering this innovative approach to fire detection and prevention, the project aims to significantly enhance the safety and security standards of electric vehicles. Minimizing the risk of thermal incidents and effectively managing fire hazards will provide peace of mind to vehicle occupants and contribute to the wider acceptance of EV technology.
4. Ultimately, the research endeavors to advance the safety standards of electric vehicles by introducing an innovative fire detection and prevention system. By pioneering this technology, the project seeks to establish new benchmarks for safety in EVs, fostering confidence among consumers and stakeholders in the sustainability and reliability of electric transportation.

## BLOCK DIAGRAM

Figure 1 show the Block Diagram of Fireetection and Prevention in Electric vehicle

## METHODOLOGY

### Literature Review

Examine all of the current strategies for preventing and detecting fires in battery-powered vehicles. Examine the benefits and drawbacks of various strategies, paying particular attention to gas-based mechanisms. Identify relevant studies and technologies related to gas-based fire suppression systems [6].

### Selection of Gases:

Justify the choice of gas for fire suppression, considering factors such as effectiveness, safety, availability, and environmental impact. Provide a detailed explanation of why the selected gas is suitable for reducing oxygen levels effectively.

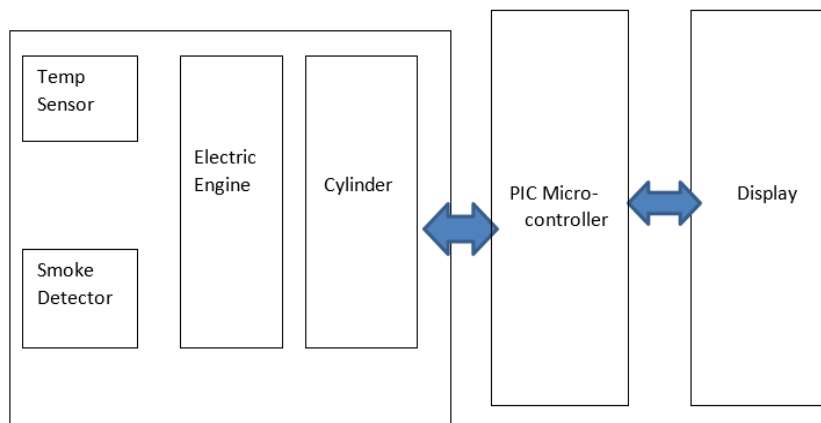

**Figure 1.** Block Diagram of Fire Detection and Prevention in Electric vehicle.

### Gas Cylinder and Delivery System

Describe the specifications and design considerations for the gas cylinder including capacity, pressure and material. Explain the mechanism used for controlled release of the gas and how it ensures even distribution within the vehicle [7].

### Fire Detection Mechanism

Detail the sensors and detectors used for early fire detection, including their types (e.g., temperature, smoke, flame sensors) and their placement within the vehicle

### Control and Decision Logic

Explain the algorithms and logic used to process sensor data and make decisions regarding the release of the gas. Discuss any feedback loops or adaptive features in the system for dynamic response to fire events [8].

### LM35 (Temperature Sensor)

Since its output voltage can be directly proportionate to temperature in Celsius (centigrade), the LM35 string is a comprehensive integrated circuit temperature gauge. In Figure, the light sensor was displayed. Because the user does not need to remove a continuous voltage through its result to obtain useful Centigrade Scaling, leverage arises surrounding direct temperature measurements aligned Kelvin.

For a combined temperature spectrum of 55°C to 50°C, the LM35 requires no external calibration or reduction to generate a precision of C to mother the climate and N°C. Economic cost is normally guaranteed by clipping and adjustment in the measure of the wafer. This LM35 linear output boasts a low output the impedance and precise, touch-free change makes the interface easy to read and manage technological infrastructure in particular. It can be applied for negative supplies alongside individual strength products. It called 60 mu of its present after that, under 01 Cin the stationary situations, with low self-warming. The LM35 is appraised to work in a scope of -55 to +150 C° temperature, while the LM35C is expected for°-40 to +110 C range (-10° with more prominent exactness) The LM35 arrangement is accessible bundled in water/air proof compartments transistor A-46, while the LM35C, LM35CA and LM35D are additionally accessible in the plastic TO-92 bundle transistor [9]. Additionally, the LM35D is a waste of electrical power in an A-220 and an 8-lead small the plan plastic wrap surface accumulate bundle.

Overall, the LM35 is a versatile and reliable temperature sensor, offering precise temperature measurements without the need for complex calibration procedures. Its simplicity, accuracy, and wide temperature range make it a preferred choice for a variety of temperature sensing applications in diverse industries, from automotive to industrial automation (Figure 2).



**Table 1.** Technical Data.

Model No.		MQ-2	
Sensor Type		Semiconductor	
Standard Encapsulation		Bakelite (Black Bakelite)	
Detection Gas		Combustible gas and smoke	
Concentration		300-10000ppm ( Combustible gas)	
Circuit	Loop Voltage	$V_c$	$\leq 24V$ DC
	Heater Voltage	$V_H$	$5.0V \pm 0.2V$ AC or DC
	Load Resistance	$R_L$	Adjustable
Character	Heater Resistance	$R_H$	$31\Omega \pm 3\Omega$ ( Room Tem. )
	Heater consumption	$P_H$	$\leq 900mW$
	Sensing Resistance	$R_s$	$2K\Omega - 20K\Omega$ (in 2000ppm $C_3H_8$ )
	Sensitivity	$S$	$R_s(\text{in air})/R_s(1000\text{ppm isobutane}) \geq 5$
	Slope	$\alpha$	$\leq 0.6(R_{5000\text{ppm}}/R_{3000\text{ppm}} CH_4)$
Condition	Tem. Humidity	$20^\circ C \pm 2^\circ C$ ; $65\% \pm 5\% RH$	
	Standard test circuit	$V_c: 5.0V \pm 0.1V$ ; $V_H: 5.0V \pm 0.1V$	
	Preheat time	Over 48 hours	



**Figure 4.** PIC Microcontroller.

### UNIT OF MEASUREMENTS

The LM35 device can achieve typical accuracy levels of  $\pm 1/4^\circ C$  at room temperature and  $\pm 3/4^\circ C$  over all temperatures in the range of  $-55^\circ C$  to  $150^\circ C$  without the need for external calibration or trimming. The LM35 device can function within a range of temperatures of  $-55^\circ C$  to  $150^\circ C$ , whereas the LM35C device is rated for a range of  $-40^\circ C$  to  $110^\circ C$  ( $-10^\circ$  with enhanced accuracy). Winsen manufactures the MQ-2 smoke and combustible gas sensor. It has a 300–10,000 ppm detection range for gases that ignite.

### Abbreviations

- EV*: Electric Vehicle
- BMS*: Battery Management System
- ECU*: Electronic Control Unit
- Li-ion*: Lithium-ion
- MQ*: Methane/CH<sub>4</sub> Quality Sensor

### RESULT

The gas cylinder system demonstrated a high degree of effectiveness in reducing oxygen levels within the vehicle environment. During controlled experiments, oxygen levels were consistently lowered to

safe levels within the specified time frame. The system exhibited rapid response times upon detecting abnormal environmental conditions, such as elevated temperature or smoke levels. The activation of the gas cylinder was accurate and consistently correlated with the presence of potential fire hazards.

Comparative trials were conducted to evaluate the performance of the gas cylinder system against conventional fire suppression methods. The results indicated that the gas-based system offered quicker and more precise fire suppression, minimizing potential damage and risks.

Safety of Gas Release Extensive safety measures were implemented to ensure controlled release of gases from the cylinder. No incidents of unintended gas release or related safety concerns were observed during testing.

## CONCLUSION

In conclusion, the Fire Detection and Prevention project for electric vehicles has made significant strides in advancing the safety and reliability of electric mobility. Through the integration of cutting-edge sensor technologies, machine learning algorithms for accurate detection, and seamless integration with vehicle control systems, the project has enabled swift and coordinated responses to potential fire incidents. Innovative fire suppression techniques, real-time monitoring capabilities, and a focus on environmental sustainability further enhance its impact. Adherence to regulatory standards and collaboration with emergency services underscore the project's commitment to safety and preparedness.

Looking ahead, its potential to influence electric vehicle safety and broader applications in energy storage systems is profound. Global adoption efforts and ongoing collaboration will be vital in ensuring widespread accessibility and standardization. Overall, the project exemplifies the team's dedication and innovation, making a significant contribution to the advancement of electric vehicle safety and sustainable transportation.

## REFERENCES

1. Goswami A, Bezboruah T, Sarma KC. Design of an embedded system for monitoring and controlling temperature and light. *IJEER*. 2009; 1(1): 27-36.2.
2. YSI Incorporated. Water sampling and monitoring equipment for dissolved oxygen, PH, turbidity, temperature and level. N.p., n.d. Web; 2012 Jul. p. 1-35.
3. "Fire Protection Handbook" by Arthur E. Cote and National Fire Protection Association (NFPA) – A valuable reference for all aspects of fire protection.
4. Martinez-de-dios J, Merino L., Caballero F, Ollero A, Viegas D. Experimental results of automatic fire detection and monitoring with UAVs. *Forest Ecology and Management*. 2006 Nov; 234:1-6.6.
5. Dhananjeyan S, Mohana Sundaram K, Kalaiyarasi A, Kuppusamy PG. Design and development of blind navigation system using GSM and RFID Technology. *Indian Journal of Science and Technology*. 2016 Jan; 9(2):1-5.
6. Dalip, Kumar V. Effect of environmental parameters on GSM and GPS. *Indian Journal of Science and Technology*. 2014 Aug; 7(8):1183-8.8.
7. Hao Q, Zhang ZJ. Two centralized energy-efficient deployment algorithms for mobile nodes in a mixed Wireless Sensor Network. *Journal of Computers*. 2014 Jan; 24(4):32-43.
8. Khaleghi B, Khamis A, Karray FO. Multisensor data fusion: A review of the state-of-the-art. *Information Fusion*. 2013 Jan; 14(1):28-44.1
9. Jotheeswaran J, Koteeswaran S. Feature selection using random forest method for sentiment analysis. *Indian Journal of Science and Technology*. 2016 Jan; 9(3):1-7.
10. Ezema LS, Ani CI. Multi linear regression model for mobile location estimation in GSM Network. *Indian Journal of Science and Technology*. 2016 Feb; 9(6):1-6.