

Design and Analysis of a Transformer-Based 9-Level Multilevel Inverter: Topologies, Operation, and Comparative Evaluation

Omkar Aher^{1*}, Debraj Bhowmick², D.B. Pardeshi³

Abstract

This paper presents information about the use of a transformer as a multilevel inverter. We propose a 9-level inverter design. In this inverter, various types of switches are used. The transformer operates with a single DC voltage input, and the output is high-quality power. A single DC input source generates a 9-level output voltage. The paper also discusses different inverter topologies, such as the cascaded type and the diode-clamped type. A complete analysis of the inverter's operation, structure, and the design of the transformer as an inverter is provided. New topologies, such as symmetric and asymmetric topologies, are also presented. The paper concludes with a comparison of inverter designs, including specifications and applications. Finally, future directions are discussed. The main goal of this paper is to understand the techniques and implementation methods based on transformer-based inverter systems to achieve higher output and better power quality.

Keywords: Inverter, transformer, voltage, topology, circuit, level, switch

INTRODUCTION

The multilevel inverter provides various types of outputs. This provided good quality power. This technology is required for various operations in the electronics sector. The coupling in the transformer is known. Therefore, it is the same as that of coupling. Various topologies are required for this operation, as discussed by Malinowski (2010) [1]. These topologies are presented in detail by Floricaeu et al. (2011) [2]. It represents the type of topology used. Topology is essential for performing specific operations. In the context of transformers, topology refers to the arrangement and structure that influence their performance. It includes the analysis of losses occurring in the transformer, its design, and overall structural configuration.

In the first topology, a single bridge type is used; however, it offers limited control. The second topology incorporates multiple capacitors connected to the circuit, making it highly efficient. The third and fourth topologies are referred to as symmetric and asymmetric, respectively, and represent newer configurations.

In the previous topic, Malinowski (2010) [1] presented a type of inverter known as the 9-level inverter. This configuration is widely used in transformer operations due to its ability to generate nine 9-level voltage outputs. The circuit diagram is briefly described, and this inverter uses eight switches. This paper focuses on providing fundamental information about the inverter. Subsequently, the implementation techniques and design of the inverter are discussed.

*Author for Correspondence

Omkar Aher
E-mail: aheromkar232@gmail.com

¹Student, Department of Electrical Engineering, Sanjivani College of Engineering, Kopargoan, Ahmednagar, Maharashtra, India

²Assistant Professor, Department of Electrical Engineering, Sanjivani College of Engineering, Kopargoan, Ahmednagar, Maharashtra, India

³Head, Department of Electrical Engineering, Sanjivani College of Engineering, Kopargoan, Ahmednagar, Maharashtra, India

Received Date: October 08, 2024

Accepted Date: December 20, 2024

Published Date: December 27, 2024

Citation: Omkar Aher, Debraj Bhowmick, D.B. Pardeshi. Design and Analysis of a Transformer-Based 9-Level Multilevel Inverter: Topologies, Operation, and Comparative Evaluation. Journal of Power Electronics & Power Systems. 2025; 15(1): 37–43p.

In the study by Bhoi (2022) [3], a comparison of inverters is presented. The 9-level inverter is compared with the proposed inverter technology, and a comparative analysis is concluded. In the study by Dhumane (2023) [4], the advantages, disadvantages, and applications of inverters are discussed. This approach offers several benefits.

The advantages of this system include high efficiency, ease of operation, reduced harmonics, and high-quality output. However, it has a costly and complex structure, and losses can occur within the transformer. These factors depend on the specific topology used. This technology is particularly suitable for electric vehicles and power distribution applications. The next section discusses the future scope of this topic, highlighting the potential for the development of new technologies. Finally, the study concludes with a summary of key findings. This topic is highly relevant to the electric power sector [5].

9-LEVEL INVERTER

Structure and Technique

This topic describes the operation of an inverter using a single-phase supply. During operation, the voltage is unidirectional, while the current flows bidirectionally. Eight switches are used in this configuration. Two legs are connected in the circuit diagram. The symbol E represents the DC source voltage. Two windings are involved in the operation: the primary and the secondary windings [6–10]. The primary winding is positioned between points A and B. The midpoints of the switches are designated as positions 1s and 2s, as shown in Figure 1. Another pair of switches, 3s, and 4s, is also located at the midpoint. The primary and secondary windings are connected at the central section of the circuit [11].

The ratio of the transformer can be represented by formula $2n$. Switching was required to produce nine different voltages. The voltages were either positive or negative [12]. The shifting configurations of the operational regions, P1 and P3, are unequal in $N1$ and $N3$. Certain losses occur in the transformer. We conduct a switching method so that switching losses may occur in this technique. Additional switching permutations are required to produce nine levels of output voltage. Furthermore, the ratio of this method is 3; therefore, we used this ratio to produce an output voltage. The energy stress is affected during this operation. The origin of the inverter is the DC voltage source. The power rating exceeds $300/2$ v, and the power is among the 300 watts [13–15].

Design and Implementation

Eight toggles were present in this method. A single DC source was the origin of this technique. One converter is attached to the circuit. Converter used for the required 9-level voltage output at maximum power. The voltage is beyond $300/2$ v and the power in the circuit is 300 V. For reference, we can say that the inverter output voltage is the highest, which is approximately. To create the design, similar steps were required.

1. The transformer ratio will need to be 3.

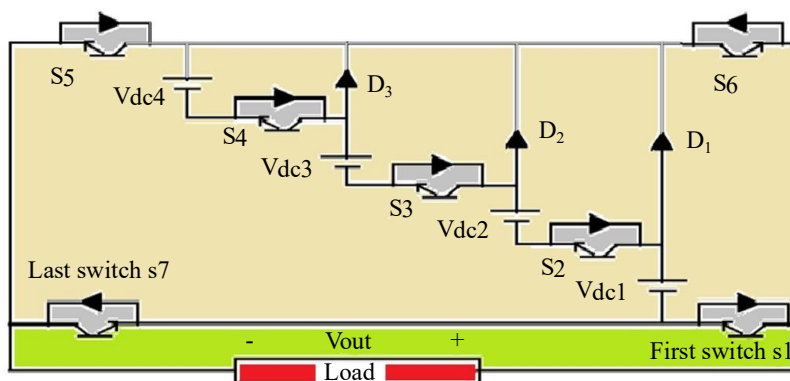

Figure 1. Circuit diagram of a 9-level inverter.

2. The DC link voltage must be equal to the inverter with the highest frequency of the AC voltage. Some losses occur in this circuit under the actual conditions.
3. The actual value of the voltage across the DC links with the peak magnitude in this waveform of the voltage output in the equivalent within the voltage source.
4. Therefore, it is necessary for the similar voltage grades taken into the imagination to be processed at least in a comparable voltage manner in the input.

Thus, the transistor experiences an overall electric stress of 600 V [16,17]. At least 50% of the switch capacity should be sufficient for the current flow, while the remaining 50% should be rated for up to three times the output current.

The current pressure of this circuit in the switches was the same as that at 32 A. The amount of output current in the given data is combined with the electric stain. Each of the four switches of the output power tripped. In addition, this method maintains that the turn ratio takes advantage of this relationship [18–20].

TOPOLOGIES IN TRANSFORMER

This implies that we study the shapes that stretch and move the points of the shape in the transformer, which are called topologies in transformers [21–23]. The various geometries affecting the transformer are the topology of the transformer. The inverter block diagram is shown in Figure 2. Topologies contain a complete analysis of this operation of the transformer. Various types of topologies exist in transformers as multi-based inverters.

Cascaded Type

It contains a direct DC source linked to various stages. An H-type bridge is used in this topology. Various voltage levels were produced in the H-type bridge. The formula for the determined output voltage is $(m=2s+1)$. The ‘s’ represents the amount of the DC source. This is the standard topology of transformers.

Several diodes are used in this topology. A direct-current bus was attached to the circuit. The diode used is a clamping-type diode. When the action of the diodes occurs, the electric stress is produced.

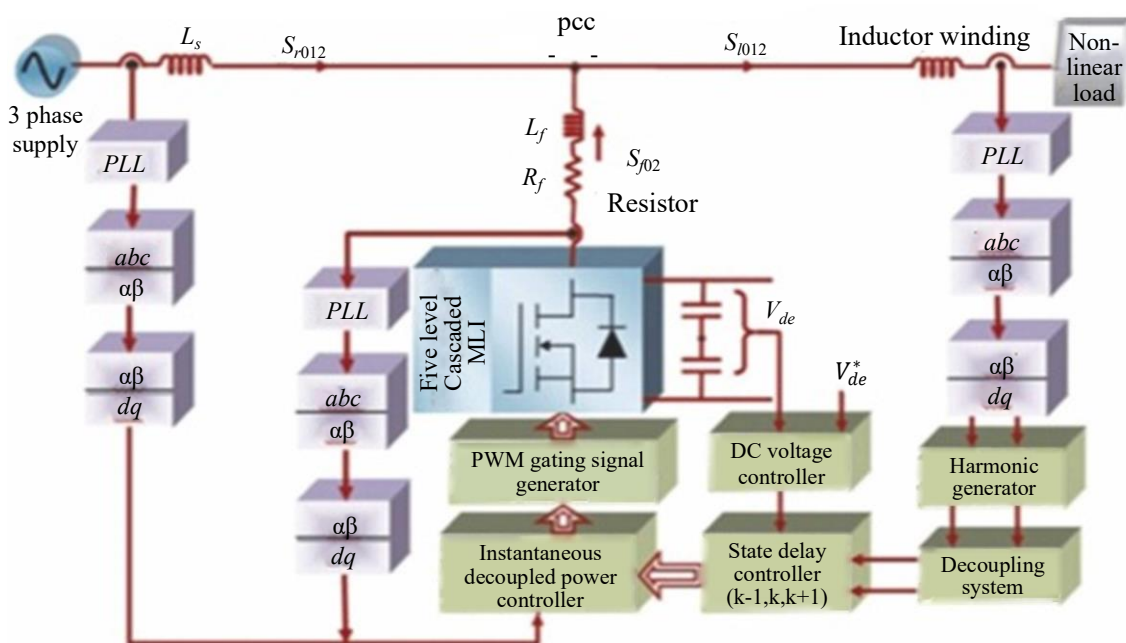

Figure 2. Block diagram of an inverter.

In each phase, the minimum amount was $(m-1)$. The 'm' represents the amount of the level. An inverter produces a high productivity. In this method, monitoring is not performed.

Diode-Clamped Type

Different numbers of capacitors are connected in this topology. It is also called the flying capacitor topology. Multilevel converters are used to reduce the voltage stress between components. The capacitor design exhibits a rung-like arrangement. A capacitor was used to regulate the strength of the circuit. The flying capacitor depends entirely on the transformer's voltage level. This is considered one of the most stable transformer topologies. Multiple capacitors are used in this configuration. Capacitors have a positive impact on voltage regulation; therefore, they are widely employed.

Symmetric Type

Symmetric topology presents an inverter that achieves the turn ratio for a transformer of the same type. The transformer ratio was 1:1. In this topology, we used a capacitor. The capacitor used in this operation the main purpose is to split the input voltage. The source is DC, and the voltage on the capacitance is volts direct current (VDC). The structure shows that the positive is zero, and the negative is the output voltage. Two switches were used: s1 and s2. When switch s1 is on, switch s2 is turned off. Similarly, switch s2 is on and s1 is off.

The primary side of the transformer is short-circuited and generates a voltage. When switches s1 and s2 are on, the primary side of the transformer is short-circuited. Switches s1 and s2 are turned off, and this switching is called desirable switching. This topology is based entirely on the switching operation.

Asymmetric Type

In asymmetric topology, the turn ratio of the transformer can be selected to maximize the number of output voltages. In this topology, the higher output voltage levels achieved fewer in the transformer and other components. The turn ratio of the transformer was sequentially changed. This topology is used to obtain the output voltage and provide better power efficiency in the transformer. Many factors and components affect transformers such as switches, gate drives, and Insulated Gate Bipolar Transistor (IGBT) transistors will be affected. We used this topology to achieve good efficiency.

COMPARISON OF THE INVERTERS AND ANALYSIS

This section presents a comparison between two inverters: the proposed inverter and the 9-level inverter. The proposed inverter uses only one DC source in the circuit and operates with a single-phase transformer supply.

The proposed inverter contains a smaller number of active elements and can generate nine output voltage levels. The 9-level inverter requires certain topologies for operation, such as the cascaded and diode-clamped types.

However, unlike the 9-level inverter, the proposed inverter does not require any capacitors, which is an advantage. On the other hand, the proposed inverter requires more components to operate, while the 9-level inverter uses fewer components.

A 9-level inverter and other topologies require four transformers, whereas the proposed inverter requires only one transformer. The proposed inverter maintains a maximum constant voltage while exhibiting lower electrical stress.

Advantages of Operation

1. The best advantage is that it reduces the harmonic effect when it generates the output voltage to provide a good waveform.

2. It reduces the electromagnetic interference.
3. The multilevel can handle and control the high voltage.
4. It gives good efficiency for the output.
5. This are easy structure so it easier to operate.
6. This method gives good quality power in the output voltages.
7. It has good grid integration for use in renewable sources.
8. Used in various hybrid vehicles to generate power.

Disadvantages of Operation

1. In this method, we used many more components, such as semiconductor devices and various types of capacitors, so that they are very stable.
2. It reduced the distortion on the waveform because it has low maintenance.
3. It gives very much clean power but, this paper can affect our instrument.
4. Complexity is affected because certain operations can give very difficult optimization.
5. We do not control easily because certain factors are affecting this method.
6. The effects of various losses occur with this method. Switching and transformer losses occur.
7. Due to many more components being added so more maintenance is required.
8. This technology depends upon the type of topologies.

Uses

- In this method we are used a couple of transformers are added to the inverter. They provide various outputs for these requirements. Addition and substation are very easy to use in this method.
- This will provide a better voltage during this operation. There is good isolation here; therefore, our safety is secure.
- This is helpful for distribution. We used a step-up and step-down transformer for the load, thus providing a very high-quality output.
- For renewable energy, we used this method to provide better results for non-conventional sources.
- There is a variable frequency given in this method; therefore, we can perform a good analysis of the frequency.

CONCLUSION

In this section, we explain the theory of the transformer as a multilevel inverter. This theory concludes that various types of information are required. In conclusion, the first is type, and next, we can understand the various topologies. Our next purpose is to compare the inverters. To understand its features, many types of specifications are presented in this study. Specifications such as advantages and uses. Thus, we can understand the future requirements of these technologies. In the future, they will become a very popular and effective technology. For the output, this is a good technology. Inverters are useful in electrical fields. It performs effectively in a transformer. In this section, we introduce rare knowledge of the electric field. This knowledge is used in various applications and included for distribution purposes.

FUTURE SCOPE

This operation has several advantages. In the future, they will be useful for various applications. The characteristics of the operation are very rare and useful for future implementation. Today's generation is shifting toward electric vehicles. In electric vehicles, various sources supply voltage and other types of power. We used our multilevel operation to obtain a much better result. Efficiency is required much more, so the technology used we obtain better efficiency in the electrical sector.

According to my suggestion, they are certain and more developed in this technology. Various types of equipment are expected to be available in the future. Various types of switches and transformers are available. With this equipment, we add new operations, so we obtain unbelievable results.

The main purpose of this process is to store energy. In the future, we will try a larger number of experiments, so much more energy is required. Therefore, this method is very useful for future experiments. Required source high voltage beyond the current limit. Thus, our operation assists. This operation transferred more voltage and power.

It is also within the environmental factor; therefore, it reduces energy losses. In addition, more energy is saved. Therefore, for saving purposes, this technology is required. In various industries, this is very useful for a large amount of production. Therefore, they have a very good future scope for transformers as multilevel inverters.

REFERENCES

1. Malinowski M, Gopakumar K, Rodriguez J, Pérez MA. A survey on cascaded multilevel inverters. *IEEE Trans Ind Electron.* 2010;57:2197–2206. DOI: 10.1109/TIE.2009.2030767.
2. Floricau D, Floricau E, Gateau G. New multilevel converters with coupled inductors: Properties and control. *IEEE Trans Ind Electron.* 2011;58:5344–5351. DOI: 10.1109/TIE.2011.2112319.
3. Bhoi SL, Salve SS, Kumar DV, Pardeshi DB, William P. Deployment of slow power hybrid electric vehicle based on combustion engine. In: *Proc 3rd Int Conf Electronics and Sustainable Communication Systems (ICESC)*; 2022. p. 231–5. DOI: 10.1109/ICESC54411.2022.9885402.
4. Dhumane RA, Nikam TD, Hajare RN, Pardeshi DB, William P. Sustainable and intelligent control strategies for electric vehicle systems. In: *Proc 2nd Int Conf Edge Computing and Applications (ICECAA)*; Namakkal, India; 2023. p. 1551–5. DOI: 10.1109/ICECAA58104.2023.10212140.
5. Dahatonde S, Jape N, Hajare RN, Pardeshi DB, William P. Arduino based vehicle overload detection system for prevention of accidents using ADC. In: *Proc 5th Int Conf Inventive Research in Computing Applications (ICIRCA)*; Coimbatore, India; 2023. p. 1633–6. DOI: 10.1109/ICIRCA57980.2023.10220821.
6. Roham MN, Kadam RS, Hajare R, Pardeshi DB, William P. Hybrid model for vehicle overload detection system using Arduino sensors. In: *Proc 5th Int Conf Inventive Research in Computing Applications (ICIRCA)*; Coimbatore, India; 2023. p. 1431–4. DOI: 10.1109/ICIRCA57980.2023.10220870.
7. Salehahari S, Babaei E. New coupled-inductor based multilevel inverter with extension capability. *J Iran Assoc Electr Electron Eng.* 2019 Feb 10;15(4):61–71.
8. Yuan X, Barbi I. Fundamentals of a new diode clamping multilevel inverter. *IEEE Trans Power Electron.* 2000;15:711–8. DOI: 10.1109/63.849041.
9. Hua CC, Wu CW, Chuang CW. Fully digital control of 27-level cascade inverter with variable DC voltage sources. In: *Proc 2nd IEEE Conf Industrial Electronics and Applications (ICIEA)*; 2007. DOI: 10.1109/ICIEA.2007.4318849.
10. Bhatane GA, Gond VJ, Chaudhari SV, William P. Real time performance monitoring of solar PV panel IoT system for energy optimization. In: *Proc 4th Int Conf Innovative Practices in Technology and Management (ICIPTM)*; Noida, India; 2024. p. 1–4. DOI: 10.1109/ICIPTM59628.2024.10563559.
11. William P, Chowdhury S, Falah A, Hussain A, Kumar R, Rao ALN. Security enhancement in IoT based smart grid system using cryptographic techniques. In: *Proc 4th Int Conf Innovative Practices in Technology and Management (ICIPTM)*; Noida, India; 2024. p. 1–6. DOI: 10.1109/ICIPTM59628.2024.10563264.
12. William P, Nirsanametla Y, Al-Samalek A, Hussain A, Varshney N, Rao A. AI and machine learning techniques for managing complexity, changes and uncertainties in manufacturing. In: *Proc 4th Int Conf Innovative Practices in Technology and Management (ICIPTM)*; Noida, India; 2024. p. 1–6. DOI: 10.1109/ICIPTM59628.2024.10563755.
13. William P, Chowdhury S, Al-Samalek A, Hussain A, Sharma K, Srivastava AP. Compounding process optimization for recycled materials using machine learning algorithms. In: *Proc 4th Int Conf Innovative Practices in Technology and Management (ICIPTM)*; Noida, India; 2024. p. 1–6. DOI: 10.1109/ICIPTM59628.2024.10563917.

14. Corzine KA, Familiant YL. A new cascaded multilevel H-bridge drive. *IEEE Trans Power Electron.* 2002;17:125–31. DOI: 10.1109/63.988678.
15. Hinago Y, Koizumi H. A single-phase multilevel inverter using switched series/parallel DC voltage sources. *IEEE Trans Ind Electron.* 2010;57:2643–50. DOI: 10.1109/TIE.2009.2030204.
16. Rodriguez J, Lai JS, Peng FZ. Multilevel inverters: A survey of topologies, controls, and applications. *IEEE Trans Ind Electron.* 2002;49:724–38. DOI: 10.1109/TIE.2002.801052.
17. Babaei E. A cascade multilevel converter topology with reduced number of switches. *IEEE Trans Power Electron.* 2008;23:2657–64. DOI: 10.1109/TPEL.2008.2005192.
18. Bibave R, Kulkarni V. Maximum power extraction from wind energy system by using perturbation and observation method. In: *Proc Int Conf Smart Electric Drives and Power System (ICSEDPS)*; Nagpur, India; 2018. p. 105–10. DOI: 10.1109/ICSEDPS.2018.8536033.
19. Yeole SS, Kolhe SV, Bibave RR, Chavan VS, Kadam BB, Bodhe VS. Design of two-wheeler hybrid electric vehicle using series parallel configuration. In: *Proc 3rd Int Conf Artificial Intelligence and Smart Energy (ICAIS)*; Coimbatore, India; 2023. p. 1595–8. DOI: 10.1109/ICAIS56108.2023.10073870.
20. Pund VS, Dongare SK, Amate PS, Jadhav DR, Bibave RR, Pardeshi DB. Soldier health monitoring and position tracking (E-vest). In: *Proc 4th Int Conf Electronics and Sustainable Communication Systems (ICESC)*; Coimbatore, India; 2023. p. 257–61. DOI: 10.1109/ICESC57686.2023.10193616.
21. Warule AS, Barde VR, Barshile MK, Kambhire SV, Bibave RR, Pardeshi DB. Electric reaping and fertilizing machine. In: *Proc 5th Int Conf Inventive Research in Computing Applications (ICIRCA)*; Coimbatore, India; 2023. p. 1685–91. DOI: 10.1109/ICIRCA57980.2023.10220941.
22. Saeedifard M, Irvani R, Pou J. Analysis and control of DC-capacitor-voltage-drift phenomenon of a passive front-end five-level converter. *IEEE Trans Ind Electron.* 2007;54:3255–66. DOI: 10.1109/TIE.2007.905967.
23. Kaliamoorthy M, Rajasekaran V, Praveen Raj G. A novel single phase cascaded multilevel inverter for hybrid renewable energy sources. In: *Proc Adv Comput Commun Syst Int Conf*; 2015. p. 1–10. DOI: 10.1109/ICACCS.2015.7324097.