

# Smart Home Safety Using Fire and Gas Detection System

Aasavari Badave<sup>1</sup>, Akanksha Pawale<sup>2</sup>, Tejaswini Andhale<sup>3</sup>, Sonali K. Godase<sup>4,\*</sup>

## Abstract

*In a world where technology is advancing at a rapid pace, one goal of smart homes is to protect the safety of the house and, most importantly, the people who live there. An essential part of our suggested systems' functionality is the inclusion of fire and gas detection sensors. The increasing use of smart homes has shown new ways of increasing security and safety through including intelligent techniques in proper ways in our proposed systems. This research paper proposes a "Smart Home Safety System" specially designed to reduce the risks comes with gas and fire uses. The system proves how we can utilize automation techniques and sensors to respond and detect threats in our day-to-day life of real-time. The basic apparatus/components of our proposed system include upgraded fire & gas detecting sensors systematically placed in the smart home architects. Those sensors continuously checks/monitors the quality of air which consists harmful gases and detects the presence of temperatures which are different from normal room temperature & smoke indicates fire. The observations which are detected from the sensors are processed to system's CCU (Central Control Unit).*

1. **Keyword:** CCU, CUBE IDE, C language, PCB Board, 5v Buzzer

## INTRODUCTION

In the world stated by rapid advancements in technologies, one perspective of smart homes is to ensure the safety of home and obviously family members, and a key of component in this is the participation of fire and gas detection sensors in our proposed systems. This transformative technology not only improves the overall safety of homes but also gives homeowners with continuous observation details and controlling capabilities [1-33].

The typical methods of gas and fire detection have transformed into interconnected, sophisticated systems that having the power of AI and smart sensors. These system goes beyond the basics of triggering alarms in the presence of gas or smoke; they are designed intelligent, proactive, and capable of effortless communication with the other smart devices. Smart home safety systems set upgraded sensors that can even detect the smallest changes in the air quality, identifies hazards such as combustible gases, carbon monoxide. The application of ML algorithms allows those projects to adapt & learn to the characteristics of a home, cancelling wrong alarms [34-66].

### \*Author for Correspondence

Sonali K. Godase  
E-mail: [sonali.karache@sknscoe.ac.in](mailto:sonali.karache@sknscoe.ac.in)

<sup>1-3</sup>Students, Department of Electronics & Telecommunication Engineering, SKN Sinhgad College of Engineering, Korti, Pandharpur, Maharashtra, India

<sup>4</sup>Assistant Professor, Department of Electronics & Telecommunication Engineering, SKN Sinhgad College of Engineering, Korti, Pandharpur, Maharashtra, India

Received Date: May 06, 2024  
Accepted Date: May 29, 2024  
Published Date: June 10, 2024

**Citation** Aasavari Badave, Akanksha Pawale, Tejaswini Andhale, Sonali K. Godase. Smart Home Safety Using Fire and Gas Detection System. Recent Trends in Fluid Mechanics. 2024; 11(1): 35–43p.

## LITERATURE REVIEW

Smith, J. et al

- *Pros:* Smith's study indicates the effectiveness of smart home gas and fire detection systems in providing continuous real-time alerts to house owners & emergency services, reducing late responses and preventing drastic events.
- *Cons:* Smith et al. point out challenges reliability issues, wrong alarms, using sensor technologies, and the need for maintaining system's effectiveness [67].

#### **Johnson, A**

- *Pros:* Johnson's research sets focus on increasing ability of home safety systems, describes their adaptability to the different layouts and sizes.
- *Cons:* On the other hand, Johnson identifies privacy constraints that are related to storage and collection of sensitive data by systems [68].

#### **Lee, C. et al**

- *Pros:* Lee's study states the role of ML algorithms in enhancing the accuracy of gas and fire detection in smart homes.
- *Cons:* Lee et al. acknowledges the resources required for the implementation of such algorithms, and the complexity of optimization & model training [69].

#### **Patel, R**

- *Pros:* Patel's review used for this paper gives overall overview of trends and technologies in the smart home safety systems, that properly includes implementing cloud computing, IoT devices, and data analytics.
- *Cons:* On this side, Patel particularly highlights the need for standards to ensure effortless integration between those different platforms and devices [70].

#### **Acknowledgement**

In the era of technology-based lifestyles, the integration of smart home safety systems has become important thing now-a-days. Gas and fire detection systems stand like bulwarks against the potential disasters, ensures the security and safety of residents. This acknowledgment gets into the main role played by the systems, highlighting the importance in modern houses and expressing the gratitude towards upgraded technologies that have made components of safety of domestic infrastructure. I extend my gratitude towards the pioneers in the field of gas and fire detection technology, whose efforts have the way for innovations, solutions that provides safety to the lives and properties. By their ingenuity and dedication, they have drastically changed the landscape of home safety, in an era of proactive prevention takes precautions over reactive actions/measures.

I also acknowledge the hardworking engineers and researchers who continuously gives their efforts towards improvement of technological capabilities and scientific knowledge. Their commitment to the excellence has resulted in field of development of communication protocols, algorithms, and cutting-edge sensors which enables the seamless working of gas and fire detecting systems into smart homes.

#### **PROBLEM STATEMENT**

In the best era of smart homes, ensuring the security of the residents is most important. Gas and fire-based incidents possesses to the dangerous threats to both property and life, making compulsory to the proactive and intelligent solutions. The current lack of efficient and integrated systems for early detection of gas and fire leakages in the smart homes is a basic thing that needs to be noticed. The absence of a solution puts the residents at a risk and may be leads to different consequences.

#### **OBJECTIVES**

Smart home safety systems designed with gas and fire detection that offers a collection of benefits. The primary advantage comes in early threat detection and enabling fast response to hazards. This early detection attached with the instant alerts, aware house-owners to take quick action, minimizing the risk of severe harm or damage. Automation features enhance the safety by triggering responses.

## METHODOLOGY

Model of proposed system is shown in Figure 1.

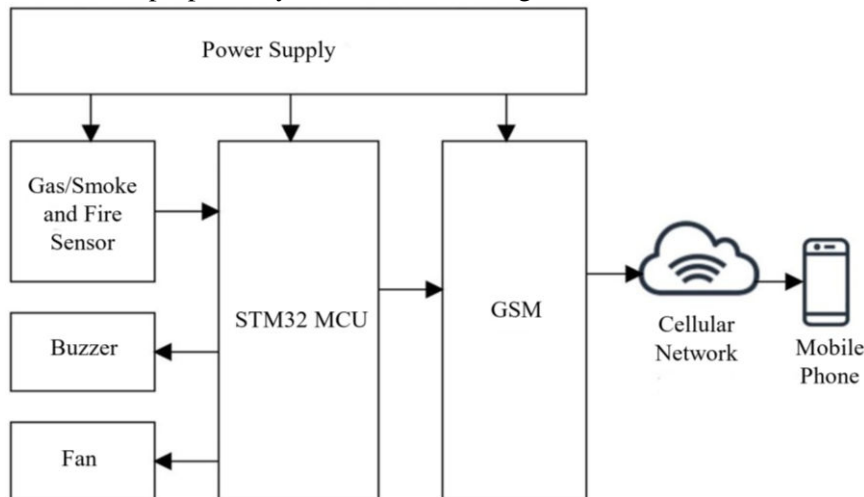

**Figure 1.** High level architecture of the proposed system.

The methodology for a home safety system using fire and gas detection involves several key steps. First, it begins with the installation of specialized sensors strategically placed throughout your home. These sensors are like tiny detectives, constantly checking the air for any signs of smoke, high temperatures, or gas leaks. When they detect something unusual, they send a signal to a central control unit. Next, the central control unit plays a crucial role. It's like the brain of the system. When it gets signals from the sensors, it decides what action to take. If there's a fire, it can trigger alarms, turn on sprinklers, and send alerts to your smartphone. If there's a gas leak, it might shut off the gas supply and notify the gas company. This way, the system acts quickly to protect you and your home, and it also keeps you informed about what's happening, even when you're not at home. In simple terms, the methodology of this system involves setting up sensors to detect problems and a smart control unit to take action and keep you safe. Pin diagram of smart home safety using fire and gas detector is shown in Figure 2.

## Program code

```
#include <Arduino.h>
#define MQ2 0
#define Flame PB12
#define Buzzer PB9
#define Fan PB8
#define built PC13
const String PHONE = "123456789101"; // Replace with your recipient's phone number
void setup ()
{
// Begin serial communication with Arduino and Arduino IDE (Serial Monitor) Serial.begin(9600);
// Begin serial communication with Arduino and A9 GSM
  Serial2.begin(115200);
  pinMode(MQ2, INPUT);
  pinMode(Flame, INPUT_PULLUP);
  pinMode(Buzzer, OUTPUT);
  pinMode(Fan, OUTPUT);
}
```

```

pinMode(built, OUTPUT);
Serial.println("Initializing...");
// Initialize A9 GSM
sendATCommand("AT");
sendATCommand("ATE1");
sendATCommand("AT+CMGF=1");
sendATCommand("AT+CNMI=1,2,0,0,0");
sendATCommand("AT+COPS=?");
sendATCommand("AT+COPS?");
sendATCommand("AT+CREG");

}
void loop()
{
    int gas =
    analogRead(MQ2)
    ; int flame =
    digitalRead(Flame
    );
    Serial.println("Gas Value: " + String(gas));
    Serial.println("Flame Status: " + String (flame == LOW? "Detected": "Not
    Detected"));if (flame == LOW || gas > 250)
    {
        sendSMS();
        digitalWrite(Bu
        zzer, HIGH);
        digitalWrite(Fa
        n, HIGH);
        digitalWrite(bui
        lt, LOW);
    }
    else
    {
        digitalWrite(Bu
        zzer, LOW);
        digitalWrite(Fa
        n, LOW);
        digitalWrite(bu
        ilt, HIGH);
        delay(5000);
    }
    delay (5000);
}
void sendSMS()
{
    Serial2.println("AT+CMGS=\"" +
    PHONE + "\"\r");delay(100);
    Serial2.println("ALERT! \nThis is an emergency in your home.\nGas leakage or
    Flame detected");Serial2.write(0x1A);
    delay (100);
}
void sendATCommand(String cmd)

```

```

    {
        Serial2.println(cm
        d);delay(100);
        while (Serial2.available())
        {
            Serial.write(Serial2.read());
        }
    }
    }
    }
    
```

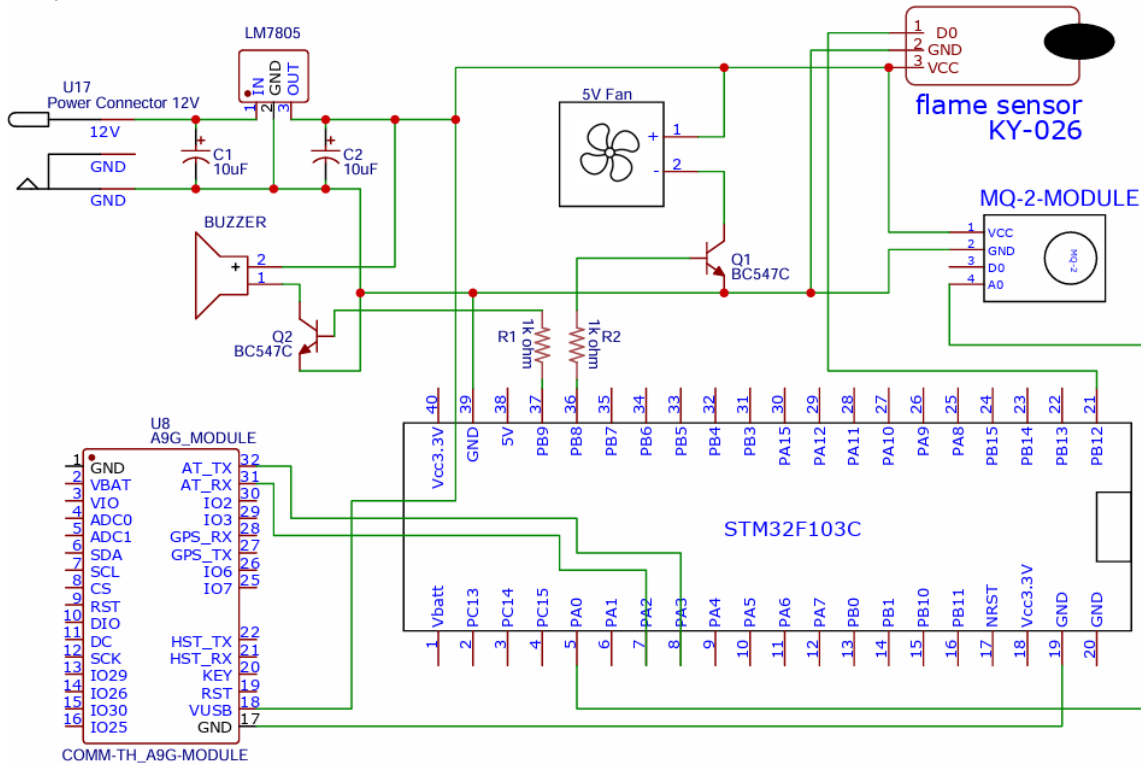

**Figure 2.** Pin diagram of smart home safety using fire and gas detector.

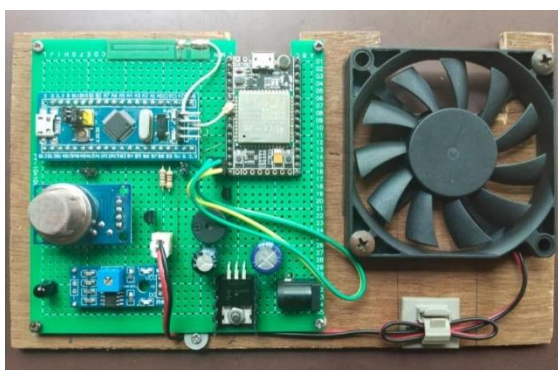

**Figure 3.** Smart home safety using fire and gas detection.

### Software & Hardware Requirements

#### Software Requirements

1. CUBE IDE
2. C language

#### Hardware requirements:

2. STM32F103C8T6 development board

3. Flame sensor
4. MQ2 Gas sensor
5. A9g GSM module
6. 5v Buzzer
7. 5v Fan
8. KA7805 Voltage Regulator
9. PCB Board
10. 9v Adapter

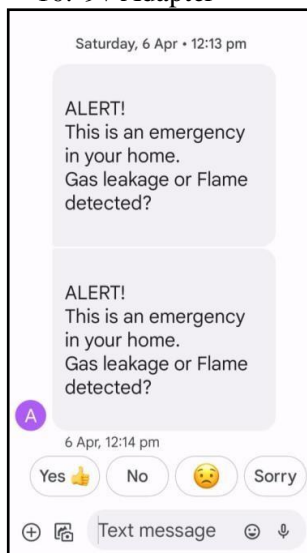

**Figure 4.** Message on house owner's phone.

## RESULTS

Our project gives the result as follows in figure 3. When we run the actual system, then it analyzes surroundings temperature using their sensors. If flame/fire detected then it starts fan and buzzer will sounds. Then simultaneously system sends a precautionary message (ALERT! This is an emergency in your home. Gas leakage or flame detected) to the house-owner's phone as shown in Figure 4.

## CONCLUSIONS AND DISCUSSION

The implementation of a smart home safety system incorporating gas and fire detection brings about a significant improvement in the overall security and well-beings. The of advanced technologies not only gives real-time monitoring but also offers an advanced active approach to reduce damages/hazards. Conclusion is that, the smart home safety system behaves like a powerful shield against gas and fire-related risks, and ensures rapid responses and minimizes the chances of catastrophic events. The integration of automation, intelligent sensors, and remotely monitoring capabilities suggests house-owners with the peace of mind and sense of control, making smart homes more resilient and safer to face of emergencies. As technology continues to evolve, and to do further refinements in smart home safety systems promising and anticipated even on maximized levels of adaptability and protection for house-owners in future.

## REFERENCES

1. Park G, Lyu G, Jo Y, Gu J, Eun J, Kim H. Development of Gas Safety Management System for Smart- Home Services. *International Journal of Distributed Sensor Networks*. 2013;9(10). doi:10.1155/2013/591027
2. L. Salhi, T. Silverston, T. Yamazaki and T. Miyoshi, "Early Detection System for Gas Leakage and Fire in Smart Home Using Machine Learning," 2019 IEEE International Conference on Consumer Electronics (ICCE), Las Vegas, NV, USA, 2019, pp. 1-6, doi: 10.1109/ICCE.2019.8661990.

3. Kunal Kumar, Navneet Sen, Sheikh Azid, Utkal Mehta, A Fuzzy Decision in Smart Fire and Home Security System, *Procedia Computer Science*, Volume 105, A Kalaiarasi., D. Deepak Kumar, B. Bharathraj, v.Naveen Vishak, S. Jasith, L. Raja, "Industry – specific Intelligent Fire Management System: A survey", 20232017
4. M. Ralevski and B. R. Stojkoska, "IoT based system for detection of gas leakage and house fire in smart kitchen environments," 2019 27th Telecommunications Forum (TELFOR), Belgrade, Serbia, 2019, pp.1-4, doi: 10.1109/TELFOR48224.2019.8971021.
5. Kweon, S.-J.; Park, J.-H.; Park, C.-O.; Yoo, H.-J.; Ha, S. Wireless Kitchen Fire Prevention System Using Electrochemical Carbon Dioxide Gas Sensor for Smart Home. *Sensors* 2022
6. Marhoon, H.M., Mahdi, M.I., Hussein, E.D., & Ibrahim, A.R. (2018). Designing and Implementing Applications of Smart Home Appliances. *Modern Applied Science*.
7. A. C. Jose and R. Malekian, "Improving Smart Home Security: Integrating Logical Sensing Into Smart Home," in *IEEE Sensors Journal*, vol. 17, no. 13, pp. 4269-4286, 1 July 2017, doi: 10.1109/JSEN.2017.2705045.
8. Deshpande, H. S. and Karande, K. J. (2014, April). Efficient implementation of AES algorithm on FPGA. In *2014 International Conference on Communication and Signal Processing* (pp. 1895-1899). IEEE.
9. Swami, S. S. (2017, August). An efficient FPGA implementation of discrete wavelet transform for image compression. In *2017 International Conference on Energy, Communication, Data Analytics and Soft Computing (ICECDS)* (pp. 3385-3389). IEEE.
10. Mane, P. B. (2018). High speed area efficient FPGA implementation of AES algorithm. *International Journal of Reconfigurable and Embedded Systems*, 7(3), 157-165.
11. Kulkarni, P. R. and; Mane, P. B. (2017). Robust invisible watermarking for image authentication. In *Emerging Trends in Electrical, Communications and Information Technologies: Proceedings of ICECIT-2015* (pp. 193-200). Springer Singapore.
12. Mane, P. B. (2016). Area efficient high speed FPGA based invisible watermarking for image authentication. *Indian journal of Science and Technology*.
13. Kashid, M. M., Karande, K. J. (2022, November). IoT-based environmental parameter monitoring using machine learning approach. In *Proceedings of the International Conference on Cognitive and Intelligent Computing: ICCIC 2021, Volume 1* (pp. 43-51). Singapore: Springer Nature Singapore.
14. Mane, D. P. (2017). An Efficient implementation of DWT for image compression on reconfigurable platform. *International Journal of Control Theory and Applications*, 10(15), 1-7.
15. Mandwale, A. J. (2015, January). Different Approaches for Implementation of Viterbi decoder on reconfigurable platform. In *2015 International Conference on Pervasive Computing (ICPC)* (pp. 1-4). IEEE.
16. Nagane, U. P. (2021). Moving object detection and tracking using Matlab. *Journal of Science and Technology*, 6, 86-89.
17. Jadhav, M. M. et al (2021). Machine learning based autonomous fire combat turret. *Turkish Journal of Computer and Mathematics Education (TURCOMAT)*, 12(2), 2372-2381.
18. Mane, D. P. (2019). High throughput and area efficient FPGA implementation of AES algorithm. *International Journal of Engineering and Advanced Technology*, 8(4).
19. Shinde, G. N. (2021). An approach for robust digital image watermarking using DWT-PCA. *Journal of Science and Technology*, 6(1).
20. Shinde G. (2019). A robust digital image watermarking using DWT-PCA. *International Journal of Innovations in Engineering Research and Technology*, 6(4), 1-7.
21. Kalyankar, P. A., Thigale, S. P., Chavhan, P. G., and; Jadhav, M. M. (2022). Scalable face image retrieval using AESC technique. *Journal of Algebraic Statistics*, 13(3), 173-176.
22. Kulkarni, P. (2015). Robust invisible digital image watermarking using discrete wavelet transform. *International Journal of Engineering Research and; Technology (IJERT)*, 4(01), 139-141.
23. Mane, D. P. (2018). Secure and area efficient implementation of digital image watermarking on reconfigurable platform. *International Journal of Innovative Technology and Exploring Engineering*, 8(2), 56-61.

24. Deshpande, H. S. and Karande, K. J. (2015, April). Area optimized implementation of AES algorithm on FPGA. In 2015 International Conference on Communications and Signal Processing (ICCSP) (pp. 0010-0014). IEEE.
25. Ghodake, R. G. (2016). Sensor based automatic drip irrigation system. *Journal for Research*, 2(02).
26. Mane, P. B. (2019). High-Speed area-efficient implementation of AES algorithm on reconfigurable platform. *Computer and Network Security*, 119.
27. Mane, P. B. (2014, October). Area optimization of cryptographic algorithm on less dense reconfigurable platform. In 2014 International Conference on Smart Structures and Systems (ICSSS) (pp. 86-89). IEEE.
28. Takale, S. (2022). DWT-PCA Based Video Watermarking. *Journal of Electronics, Computer Networking and Applied Mathematics (JECNAM) ISSN*, 2799-1156.
29. Patale, J. P., Jagadale, A. B., and; Pise, A. (2023). A Systematic survey on Estimation of Electrical Vehicle. *Journal of Electronics, Computer Networking and Applied Mathematics (JECNAM) ISSN*, 2799-1156.
30. Jadhav, M. M., and; Seth, M. (2022). Painless machine learning approach to estimate blood glucose level with non-invasive devices. In *Artificial Intelligence, Internet of Things (IoT) and Smart Materials for Energy Applications* (pp. 83-100). CRC Press.
31. Kondekar, R. P. (2017). Raspberry Pi based voice operated Robot. *International Journal of Recent Engineering Research and Development*, 2(12), 69-76.
32. Maske, Y., Jagadale, A. B., and; Pise, A. C. (2023). Development of BIOBOT System to Assist COVID Patient and Caretakers. *European Journal of Molecular and Clinical Medicine*, 3472-3480.
33. Maske, Y., Jagadale, M. A., and; Pise, M. A. (2021). Implementation of BIOBOT System for COVID Patient and Caretakers Assistant Using IOT. *International Journal of Information Technology and; Amp*, 30-43.
34. Jadhav, H. M., Mulani, A., and; Jadhav, M. M. (2022). Design and development of chatbot based on reinforcement learning. *Machine Learning Algorithms for Signal and Image Processing*, 219-229.
35. Gadade, B. (2022). Automatic System for Car Health Monitoring. *International Journal of Innovations in Engineering Research and Technology*, 57-62.
36. Kamble, A., (2022). Google assistant based device control. *Int. J. of Aquatic Science*, 13(1), 550-555.
37. Mandwale, A., and; Mulani, A. O. (2015, January). Different Approaches for Implementation of Viterbi decoder. In *IEEE International Conference on Pervasive Computing (ICPC)*.
38. Mulani, A. O., Jadhav, M. M., and; Seth, M. (2022). Painless Non-invasive blood glucose concentration level estimation using PCA and machine learning. *The CRC Book entitled Artificial Intelligence, Internet of Things (IoT) and Smart Materials for Energy Applications. Internet of Things (IoT) and Smart Materials for Energy Applications*.
39. Boxey, A., Jadhav, A., Gade, P., Ghanti, P., and; Mulani, A. O. (2022). Face Recognition using Raspberry Pi. *Journal of Image Processing and Intelligent Remote Sensing (JIPIRS) ISSN* 2815-0953.
40. Takale, S., and; Mulani, D. A. Video Watermarking System. *International Journal for Research in Applied Science and; Engineering Technology (IJRASET)*, 10.
41. Shinde, M. R. S., and; Mulani, A. O. (2015). Analysis of Biomedical Image Using Wavelet Transform. *International Journal of Innovations in Engineering Research and Technology*, 2(7), 1-7.
42. Mandwale, A., and; Mulani, A. O. (2014, December). Implementation of Convolutional Encoder and; Different Approaches for Viterbi Decoder. In *IEEE International Conference on Communications, Signal Processing Computing and Information technologies*.
43. Ghodake, R. G., and; Mulani, A. O. (2018). Microcontroller Based Automatic Drip Irrigation System. In *Techno-Societal 2016: Proceedings of the International Conference on Advanced Technologies for Societal Applications* (pp. 109-115). Springer International Publishing.
44. Mulani, A. O., and; Mane, P. B. (2016), "Fast and Efficient VLSI Implementation of DWT for Image Compression", *International Journal of Control Theory and Applications*, 9(41), pp.1006-1011.
45. Shinde, R., and; Mulani, A. O. (2015). Analysis of Biomedical Image. *International Journal on Recent and; Innovative trend in technology (IJRITT)*.

46. Patale, J. P., Jagadale, A. B., Mulani, A. O., and; Pise, A. (2022). Python Algorithm to Estimate Range of Electrical Vehicle. *Telematique*, 7046-7059.
47. Utpat, V. B., Karande, D. K., and; Mulani, D. A. Grading of Pomegranate Using Quality Analysis. *International Journal for Research in Applied Science and; Engineering Technology (IJRASET)*, 10.
48. Mulani, A. O., Jadhav, M. M., and; Seth, M. (2022). Painless Non-invasive blood glucose concentration level estimation using PCA and machine learning. *The CRC Book entitled Artificial Intelligence, Internet of Things (IoT) and Smart Materials for Energy Applications*.
49. Mandwale, A., and; Mulani, A. O. (2016). Implementation of High Speed Viterbi Decoder using FPGA. *International Journal of Engineering Research and; Technology (IJERT)*.
50. Kambale, A. (2023). HOME AUTOMATION USING GOOGLE ASSISTANT. *UGC care approved journal*, 32(1).
51. Sawant, R. A., and; Mulani, A. O. Automatic PCB Track Design Machine. *International Journal of Innovative Science and Research Technology*, 7(9).
52. ABHANGRAO, M. R., JADHAV, M. S., GHODKE, M. P., and; MULANI, A. Design And Implementation Of 8-bit Vedic Multiplier. *JournalNX*, 24-26.
53. Seth, M. (2022). Painless Machine learning approach to estimate blood glucose level of Non-Invasive device. *Artificial Intelligence, Internet of Things (IoT) and Smart Materials for Energy Applications*.
54. Korake, D. M., and; Mulani, A. O. (2016). Design of Computer/Laptop Independent Data transfer system from one USB flash drive to another using ARM11 processor. *International Journal of Science, Engineering and Technology Research*.
55. Mulani, A. O., Birajadar, G., Ivković, N., Salah, B., and; Darlis, A. R. (2023). Deep learning based detection of dermatological diseases using convolutional neural networks and decision trees. *Treatment du Signal*, 40(6), 2819-2825.
56. Pathan, A. N., Shejal, S. A., Salgar, S. A., Harale, A. D., and; Mulani, A. O. (2022). Hand Gesture Controlled Robotic System. *Int. J. of Aquatic Science*, 13(1), 487-493.
57. Dr. Altaf O. Mulani. (2024). A Comprehensive Survey on Semi-Automatic Solar-Powered Pesticide Sprayers for Farming. *Journal of Energy Engineering and Thermodynamics (JEET) ISSN 2815-0945*, 4(02), 21–28. <https://doi.org/10.55529/jeet.42.21.28>
58. Sandeep Kedar and A. O. Mulani (2024), IoT Based Soil, Water and Air Quality Monitoring System for Pomegranate Farming, *NATURALISTA CAMPANO*, Vol. 28, Issue 1.
59. Bhanudas Gadade, A O Mulani and A.D.Harale (2024). IOT Based Smart School Bus and Student Monitoring System. *NATURALISTA CAMPANO*, Vol. 28, Issue 1.
60. Anil Dhanawade, A. O Mulani and Anjali. C. Pise. (2024). Smart farming using IOT based Agri BOT. *NATURALISTA CAMPANO*, Vol. 28, Issue 1.
61. Dr. Shweta Sadanand Salunkhe and Dr. Altaf O. Mulani. (2024). Solar Mount Design Using High-Density Polyethylene. *NATURALISTA CAMPANO*, Vol. 28, Issue 1.
62. Sarda, M., Deshpande, B., Deo, S., and; Karanjkar, R. (2018). A comparative study on Maslow's theory and Indian Ashrama system." *International Journal of Innovative Technology and Exploring Engineering*, 8(2), 48-50.
63. Deo, S., and; Deo, S. (2019). Cybersquatting: Threat to domain name. *International Journal of Innovative Technology and Exploring Engineering*, 8(6), 1432-1434.
64. Shambhavee, H. M. (2019). Cyber-Stalking: Threat to People or Bane to Technology. *International Journal on Trend in Scientific Research and Development*, 3(2), 350-355.
65. Deo, S., and; Deo, D. S. (2019). Domain name and its protection in India. *International Journal of Recent Technology and Engineering*.
66. Sarda, M., Deshpande, B., Deo, S., and; Pathak, M. A. (2018). Intellectual Property And Mechanical Engineering-A Study Emphasizing The Importance Of Knowledge Of Intellectual Property Rights Amongst Mechanical Engineers. *International Journal of Social Science and Economic Research*, 3(12), 6591-6596.
67. Jetter J, Zhao Y, Smith KR, Khan B, Yelverton T, DeCarlo P, Hays MD. Pollutant emissions and energy efficiency under controlled conditions for household biomass cookstoves and implications

- 
- for metrics useful in setting international test standards. *Environmental science & technology*. 2012 Oct 2;46(19):10827-34.
68. Johnson KB, Stockwell V. Management of fire blight: a case study in microbial ecology. *Annual review of phytopathology*. 1998 Sep;36(1):227-48.
69. Giri PC, Chowdhury AM, Bedoya A, Chen H, Lee HS, Lee P, Henriquez C, MacIntyre NR, Huang YC. Application of machine learning in pulmonary function assessment where are we now and where are we going?. *Frontiers in physiology*. 2021 Jun 24;12:678540.
70. Patel S, Park H, Bonato P, Chan L, Rodgers M. A review of wearable sensors and systems with application in rehabilitation. *Journal of neuroengineering and rehabilitation*. 2012 Dec;9:1-7.