

Fuel Less Slingshot Rocket to Fly a Certain Distance Using Costless and Ecofriendly Fuel

Sharad Panchal^{1,*}, Sagar Modale²

Abstract

In this study, the rocket travels a certain distance by utilizing the force provided by the alternative of using potassium nitrate (KNO_3) and sugar ($C_{12}H_{22}O_{11}$). This initial burst reduces the amount of fuel needed for the rocket to achieve the necessary speeds and altitudes. Slingshot physics involves using stored elastic energy to shoot something at high speed. This energy comes from specially made elastic bands for slingshots and is initially provided by the muscle energy of the slingshot operator. In practice, the rubber tubes of the slingshot are stretched and secured at a specific point. The rocket is then placed in that position according to a predetermined design, and the secured slingshot tubes are released. This propels the rocket up to a certain distance with the force of the slingshot, after which the rocket continues using its own fuel. As the rocket reaches higher velocities, air resistance increases, which counteracts the force provided by the slingshot. This resistance must be carefully managed to ensure efficient propulsion. This concept also helps save fuel costs. Initially, only money is needed to build the stand, and it can be used repeatedly to launch such rockets. The concept saves fuel by utilizing elastic energy for the initial phase of the launch. The rocket's own fuel is used only after the elastic energy is depleted, allowing it to continue its journey into space. The slingshot launcher stand requires an initial investment for construction. However, once built, it can be reused for multiple rocket launches, leading to a significant reduction in long-term costs.

Keywords: Launcher stand, elastic rubber, Bowl, prepared rocket, hanking hooks

INTRODUCTION

A solid rocket, also known as a solid-fuel rocket, is a type of rocket that utilizes solid propellants such as fuel or oxidizer in its motor. The earliest rockets were solid-fuel rockets powered by gunpowder, which were utilized by the Chinese, Indians, Mongols, and Arabs in warfare as early as the 13th century [1]. The development of the rocket has transformed it into an essential tool for space exploration. The rocket first appeared in history as a fire arrow used by the Chin Tartars in 1232 AD to defend against a Mongol attack on Kai-feng-fu [2].

*Author for Correspondence

Sharad Panchal
E-mail: panchalsharad54@gmail.com

¹Student, Department of Electrical Engineering, Marathwada Institute of Technology (MIT) Engineering College, Aurangabad, Maharashtra, India

²Assistant Professor, Department of Electrical Engineering, Marathwada Institute of Technology (MIT) Engineering College, Aurangabad, Maharashtra, India

Receiving Date: July 16, 2024
Accepted Date: July 30, 2024
Published Date: August 05, 2024

Citation: Sharad Panchal, Sagar Modale. Fuel Less Slingshot Rocket to Fly a Certain Distance Using Costless and Ecofriendly Fuel. Journal of Aerospace Engineering & Technology. 2024; 14(2): 14–19p.

Conventional aviation and rocket fuels are complex hydrocarbon mixtures containing hundreds to thousands of chemical compounds. Historically, combustion chemistry modeling of these fuels has taken a fuel surrogate approach [3–5]. After decades of relative stagnation, there has been a spectacular surge of interest in recent years towards multiple activities in space, both from governmental and commercial entities, with the birth of the so-called New Space Economy [6, 7].

Rocket science has always been complicated, not only because it deals with rocket dynamics, attitude control, and propulsion system properties, but also

because of the complexity that arises from its payload. Whether it is manned or unmanned, the question remains: how do we get that payload into orbit? How do we combine them in orbit to form giant structures like space stations? And most importantly, how do the mechanics and aerodynamics of the shuttle interact with lifting the rocket? This article aims to simplify complex terminology, difficult mathematics, and painstaking equations into simple rules for the general reader. It does not require any prerequisite knowledge in the field to study it. "A Simplified Guide to Rocket Science and Beyond-Understanding the Technologies of the Future" by Deep Bhattacharjee and Sanjeevan Singha Roy [8].

The single most important property of elastomers is their ability to undergo large elastic deformations. In this article, the theoretical treatment is briefly outlined and shown to account quite successfully for the observed elastic behavior of rubbery materials. The special case of small elastic deformations is then discussed in some detail due to its technical importance. Finally, attention is drawn to some aspects of rubber elasticity that are still little understood (A.N. Gent, [9]). The slingshot effect is an intriguing phenomenon that NASA has effectively used to send spacecraft to the outer edges of the solar system. This phenomenon can be satisfactorily explained by Newtonian physics. However, when presented as a problem involving four-momentum conservation, the methods of relativistic kinematics easily led to the conditions necessary for both an accelerating and a retarding scenario. This problem provides an example that showcases the frequent utility of relativistic methods in analyzing problems of Newtonian mechanics [1]. This research paper aims to design a new fuel, optimize and test a prototype launcher stand (LS), and evaluate its mechanical efficiency. This method involves developing a new fuel for rocket launches.

MATERIAL AND METHODS

Collection of Materials and Chemicals

An iron LS, elastic band, plastic pipe, potassium nitrate (KNO_3), sugar ($\text{C}_{12}\text{H}_{22}\text{O}_{11}$), and potassium nitrate were used for rocket fuel purchased from the local market in Aurangabad, Maharashtra, India.

Preparation of Rocket Fuel

Potassium nitrate and sugar are used to make rocket fuel. The ratio of potassium nitrate to sugar was taken as 3:2 wt/wt. Initially, KNO_3 and $\text{C}_{12}\text{H}_{22}\text{O}_{11}$ were placed into a beaker. Then, enough water was added to completely dissolve the KNO_3 and $\text{C}_{12}\text{H}_{22}\text{O}_{11}$. The suspension was boiled until all the water evaporated, leaving behind a candy-like substance [10].

Preparation of Rocket and Launcher Stand

First, the LS is placed neatly on the ground. Elastic bands attached to the rod on both sides of the LS are then connected to the bowl. Next, the "V"-shaped wires on the underside of the bowl are fixed into the appropriate holes out of the 5 holes by the rod. Once all arrangements of the LS are fixed, the fuel tank of the rocket is placed in the bowl. The entire body of the rocket is then fitted into a semi-circular pipe. Once the rocket and LS are properly positioned, the rope attached to the rod (connect and disconnect rod) is made horizontal (parallel to the ground). At the right time, the rope is pulled hard, causing the rod to come out of the hole and disconnect from the bowl rod. The elastic energy of the bands then propels the rocket into the air. After the elastic energy is exhausted, the rocket ignites its own fuel tank and continues flying.

The height of the LS is 10 feet, and it weighs 22 kg. The shape of the L.S. is a Christian cross shape, with two steel rods attached above it, each 20 cm in length. Five elastic bands are attached to each rod, with five holes in a straight line on the lower side of the L.S. The distance between each hole is 10 cm to stretch the elastic band as needed. The rods are attached at the bottom to secure the L.S. to the ground. A small, adjustable steel bowl is designed to fit the fuel tank on the underside of the rocket, weighing 150 g. Two "U"-shaped hooks are attached to the sides of the bowl, with "V"-shaped strings underneath. A round steel plate is placed in the bowl to keep the fuel tank upright. The 5-hole arrangement is to prevent overstretching of the elastic bands, with a radius of 0.5 cm. A 10 cm steel rod can connect and



Figure 1. Elastic bands.

disconnect the bowl. A hemispherical pipe, 2 feet in length, is attached to ensure the rocket goes straight. A straight plastic plate is used to fit the rocket in the hemispherical pipe. The elastic bands have a diameter size of OD 5 mm × ID 3 mm, with a length of 2 feet. There are a total of 10 elastic bands, which can be adjusted based on the weight of the rocket.

Elastic bands are bands made of natural or synthetic rubber, round in shape, with high physical properties such as elasticity, strength, and flexibility (Figure 1). When pulled for a distance and then released, they return to their original position. The energy stored in the elastic band is determined by the band's spring constant (k) and how far the rubber band is stretched. For each type of elastic band, the maximum elastic potential energy (PE) can be calculated using the number using the formula:

$$PE = \frac{1}{2}kx^2$$

To calculate tension: (total weight on scale) – (rocket body weight) – (bar weight) = band tension (1)

RESULTS AND DISCUSSION

Rocket Fuel and Trial

The speed of a rocket with a weight of 2 kg is 2500 m/s. This rocket requires less fuel compared with other rockets (non-slingshot launch). The more the elastic band is stretched, the faster the rocket accelerates. There is no smoke emitted when the slingshot rocket launches. Once the elastic energy is depleted, the rocket ignites its fuel tank and releases smoke into the sky. The concept of the slingshot rocket in rocket science represents a significant advancement by utilizing the properties of a slingshot mechanism [11]. This approach offers numerous advantages: a rocket weighing 2 kg can achieve a launch speed of 1323 km/h. The speed increases with the degree of elastic band stretch, showing that more elastic energy results in higher initial velocities [12]. The slingshot rocket launches without emitting smoke, contributing to a cleaner launch process. Once the elastic energy is depleted, the rocket's fuel tank activates and releases smoke at higher altitudes, reducing ground-level pollution. By incorporating a slingshot mechanism into rocket launches, this concept not only optimizes fuel usage and costs but also introduces a versatile and reusable launching system. It paves the way for more economical, efficient, and environmentally friendly rocket designs. The LS facilitates the soft launch of the rocket. Rocket balancing is excellent due to the LS, as shown in (Figure 2). The stand is positioned perpendicular to the ground, with the lower end buried 3 feet into the ground. Initially, the hollow round pipe is adjusted to keep the rocket's direction straight.

The hemispherical pipe has holes drilled at appropriate distances to ensure proper fitting on the stand. It has a height of 3 feet and a radius of 3 cm. To guarantee stability and functionality, the bottom of the Slingshot LS must be securely buried into the ground, maintaining its upright position during launch. This foundational stability is essential for the accurate and efficient operation of the launcher (Figure 3).

The LS is equipped with a hemispherical pipe that is firmly connected to the main structure using nuts and bolts. This pipe acts as a guide for the rocket, ensuring that it follows a precise path when launched. The use of nuts and bolts facilitates easy assembly, disassembly, maintenance, and adjustment as needed (Figure 4). Elastic bands are fitted to the side rods of the LS. The side rod is strategically positioned to maximize the elastic potential energy stored in the band. Attached to the elastic band is a bowl, designed to hold the rocket securely before launch. The bowl ensures that the rocket remains

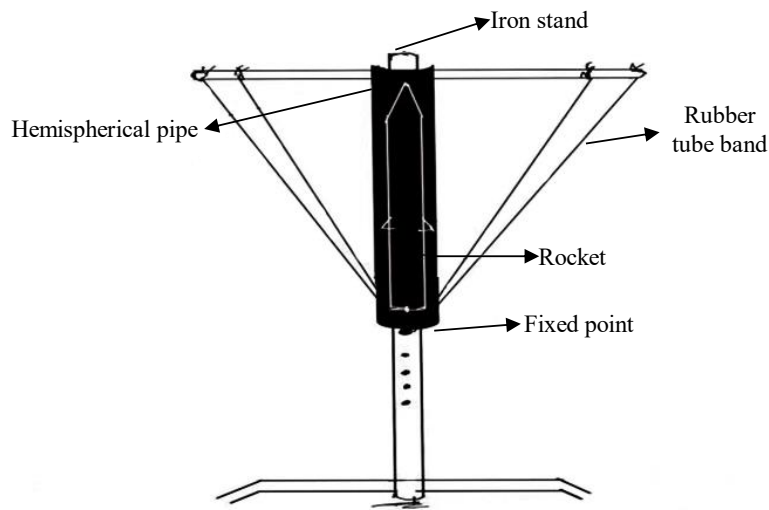

Figure 2. Rocket connected to the slingshot launcher stand.

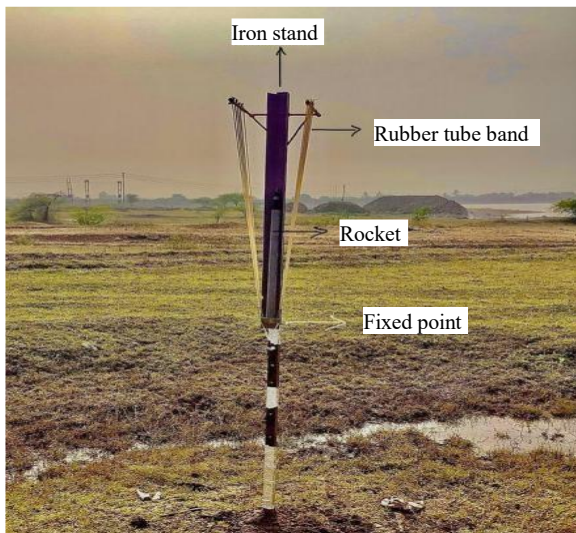

Figure 3. Rocket ready for installation.

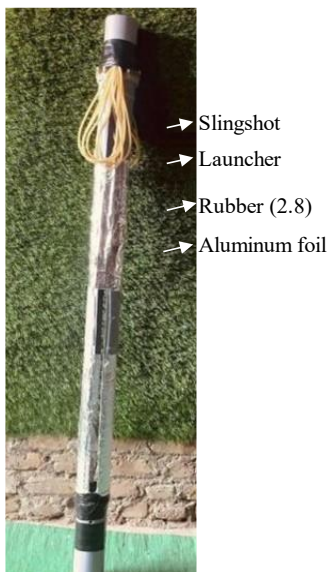

Figure 4. Prepared rocket.

stable and properly aligned with the launch path, preventing any misfires or misdirections. During the launch process, the elastic band is stretched, storing potential energy. When released, this energy is converted into kinetic energy, propelling the rocket along the hemispherical pipe and into the air. This innovative setup eliminates the need for conventional fuel, significantly reduces carbon dioxide (CO₂) emissions, and promotes a more sustainable approach to rocket launch.

Optimization of Speed of the Rocket

To optimize the speed of the rocket, the C₁₂H₂₂O₁₁ to KNO₃ ratio was varied from 2:1 to 2:5 by weight. These experiments were conducted using a fuel weight of 1 kg, with a total rocket body weight of 2 kg maintained (Table 1). The speed of the rocket increased with higher concentrations of KNO₃, with a 2:3 ratio providing the highest speed of 1323 km/h. Speeds of 1200 km/h and 1198 km/h were achieved at ratios of 2:2 and 2:4, respectively. Therefore, the 2:3 ratio was deemed most suitable for maximizing the rocket's speed.

Table 1. Optimization of sugar and potassium nitrate ratio for rocket fuel.

C ₁₂ H ₂₂ O ₁₁ :KNO ₃ ratio	Fuel weight (kg)	Rocket body weight (kg)	Total Rocket weight (kg)	Speed (km/h)
2:1	1	1	2	1103
2:2	1	1	2	1200
2:3	1	1	2	1323
2:4	1	1	2	1198
2:5	1	1	2	1003

Mechanism of Slingshot Rocket

The design and materials used to manufacture the slingshot launcher are selected for durability and performance, ensuring that the system can withstand repeated use without significant wear or degradation. This approach not only provides an environmentally friendly alternative to conventional rocket launches but also contributes to the development of cost-effective and reusable launch technologies. The concept involves using stored elastic energy from specially designed bands to launch rockets, reducing initial fuel requirements. Elastic bands, similar to a slingshot mechanism, are stretched and secured to a fixed point. When released, they propel the rocket over a certain distance. This initial burst of acceleration minimizes the reliance on onboard fuel for achieving necessary speeds and altitudes. After the elastic energy is depleted, the rocket transitions to using its own propulsion systems. As velocity increases, air resistance also increases, necessitating careful management for efficient propulsion. The approach saves on fuel costs by leveraging elastic energy initially, with the LS requiring an initial construction investment but offering reusability for multiple launches. This design ensures long-term cost reduction and promotes sustainability in rocket launches.

CONCLUSION

In rocket science, the slingshot rocket concept was developed by examining the properties of a slingshot mechanism. This innovative approach offers significant benefits and efficiencies. The single LS can be utilized for various rocket designs, providing flexibility and reusability. Fuel costs are reduced by 40% compared with traditional rockets that do not use a slingshot mechanism. This cost reduction is achieved through the efficient use of the slingshot mechanism, which requires less fuel for propulsion. Additionally, the design of the rocket allows for a smaller fuel tank, contributing to overall weight savings and increased efficiency. By incorporating a slingshot mechanism into rocket launches, this concept optimizes fuel usage and costs while introducing a versatile and reusable launching system. This innovation paves the way for more economical and adaptable rocket designs. The LS is a structured support system for launching rockets, featuring adjustable tensioning through elastic bands and multiple attachment points for flexibility. It includes secure mechanisms for holding the rocket's fuel tank and ensuring a straight launch trajectory via a hemispherical guide pipe. The use of elastic bands helps provide controlled tension, which can be adjusted based on the rocket's weight.

REFERENCES

1. Dykla JJ, Cacioppo R, Gangopadhyaya A. Gravitational slingshot. *Am J Phys.* 2004; 72 (5): 619–621. Doi: 10.1119/1.1621032.
2. Singh DA. Sugar-based rocket propulsion system: making, analysis & limitations. *Int J Eng Trends Appl.* 2015; 2 (5): 18–22.
3. Violi A, Yan S, Eddings EG, Sarofim AF, Granata S, Faravelli T, et al. Experimental formulation and kinetic model for JP-8 surrogate mixtures. *Combust Sci Technol.* 2002; 174 (8): 399–417.
4. Colket M, Edwards T, Williams S, Cernansky NP, Miller DL, Egolfopoulos F, et al. Development of an experimental database and kinetic models for surrogate jet fuels. In: 45th AIAA Aerospace Sciences Meeting and Exhibit; Reno, NV, USA: AIAA; 2007. Paper No. 2007-770.
5. Eddings EG, Yan S, Ciro W, Sarofim AF. Formulation of a surrogate for the simulation of jet fuel pool fires. *Combust Sci Technol.* 2005; 177 (4): 715–739.
6. BryceTech. Start-up space report 2022. Alexandria, VA, USA: BryceTech; 2022.
7. BryceTech. Smallsats by the numbers 2023. Alexandria, VA, USA: BryceTech; 2023.
8. Bhattacharjee D, Roy SS. A simplified guide to rocket science and beyond: understanding the technologies of the future. *TechRxiv.* 2023. Doi: 10.36227/TechRxiv.22338391.v1.
9. Gent AN. Rubber elasticity: Basic concepts and behavior. In: Gent AN, editor. *Engineering with rubber: how to design rubber components.* 2nd ed. Oxford, England, The United Kingdom: Elsevier; 2013. 1–34 p. Doi: 10.1016/B978-0-12-394584-6.00001-7.
10. Lopez-Telgie A, Murcia Pineros JO, Morales-Verdejo C. Characterization of potassium nitrate/dextrose solid rocket propellant using calorimetry. *J Chil Chem Soc.* 2023; 68 (1): 5762. Doi: 10.4067/S0717-97072023000105762.
11. Danby JMA. The gravity assist: Concept and applications. *J Astronaut Sci.* 1962; 9 (3): 200–210.
12. Vishalashi R. Application of Hooke's law in elasticity. *Indian J Res.* 2017; 6 (11): 75–78.