



Smart Card Based Lineman Safety

Sanket Bankar^{1,*}, Mahesh Thorve², Ruchika Lad³, Prof. Sharad Patil⁴

Abstract

As maintenance workers and electrical substations are being repaired, there are more electrical mishaps involving linemen today. Contact with overheated wires is the most frequent reason for electric shock and electrocution in the workplace, but there are other factors as well. When transporting equipment like poles and ladders, this happens when people underestimate the height of the ground and overhead wires. Not separating electrical supply is another common cause of electrical injury. working on electrical equipment that is "live," A lack of maintenance Even if you survive an electrical shock, there may be serious aftereffects, such as burns, eye damage, partial limb paralysis, neurological issues including forgetfulness and memory loss, and injuries sustained immediately after the shock (such as falling off a ladder). Therefore, we create projects for linemen or electricians to prevent electrical injuries.

Keywords: Arduino nano, Microcontroller, RFID, Relay, Jump Wire.

INTRODUCTION

The 8-bit microcontroller, a member of the Arduino family, controls the entire system. In this case, we are using two microcontrollers, one of which is mounted on a pole and the other on a fuse box for power distribution. RF The RF receiver and switching circuit are interfaced with the microcontroller that is mounted on the power distribution fuse box, and the transmitter and sensor are mounted on the pole. There are many overhead lines in a city or village. One main pole is included on each line. The main pole of each line is where the smart card exchange circuit is located. The microprocessor reacts and transmits a signal through an RF transmitter when a lineman or electrician switches their card to turn off a sensor installed on the main pole of each line. When an electrician or lineman switches cards on the power-turn-off sensor installed on the main pole of each line, the microcontroller responds by transmitting a signal via RF, which an RF receiver can then receive and process to turn off the power to that line via a power-distribution fuse box. When a line worker has finished his or her task, the switch will activate the sensor and cause the microcontroller to send a signal to the microcontroller of the power distribution fuse box. There is a significant chance of a communication gap between the electric lineman and the sub-station operator or staff whenever any issues arise on distribution lines. Linemen are required to notify the substation operator to cut the power to the line that has malfunctioned. They can accomplish this by calling the substation operator or by physically visiting the substation to perform maintenance on the distribution line. A transformer, other parts, a domestic appliance, or the life of an electric lineman could all be at risk due to this communication gap.

*Author for Correspondence

Sanket Bankar
E-mail: Sanketbankar0@gmail.com

¹⁻³Student, Department of Electrical Engineering, NBN Singhad Technical Institute Campus, Savitribai Phule Pune University, Maharashtra, India

⁴Assistant Professor, Department of Electrical Engineering, NBN Singhad Technical Institute Campus, Savitribai Phule Pune University, Maharashtra, India

Received Date: September 18, 2023

Accepted Date: October 13, 2023

Published Date: October 16, 2023

Citation: Sanket Bankar, Mahesh Thorve, Ruchika Lad, Prof. Sharad Patil. Smart Card Based Lineman Safety. International Journal of Electrical and Communication Engineering Technology. 2023;1(1): 1-7p.

An Electrical Breaker

An electrical switch known as a circuit breaker is designed to protect an electrical circuit from

damage caused by overload or short circuit. Its primary responsibility is to detect a failure state and interrupt current flow. The regular operation of a circuit breaker can be restored either manually or automatically, in contrast to a fuse that needs to be changed after just one use. Due to a lack of coordination and communication between the maintenance staff and the employees of the electric substation, we observe an increase in deadly electrical incidents involving linemen when operated manually. To avoid such mishaps, the breaker can be designed so that only allowed users can control it with a password.

LITERATURE REVIEW

A Perfect method to prevent electrical damage and death did not exist in earlier times. If someone turns on the power supply, an electrician can manually switch it off from the power distribution box and then proceed to their job on the electrical pole. Electrical accidents or fatalities will have an impact on electricians. We are currently developing an RFID smart card-based lineman protection solution. The safety system for electric linemen employs a novel password idea. The lack of coordination and communication between the maintenance staff and the electric substation employees is shown to be a contributing factor to the rise in deadly electrical accidents involving linemen during electric line repairs. So, to prevent this, a password-based circuit breaker is being used. These passwords give the system complete control to turn the supply to each line on or off. The line can be turned ON or OFF by maintenance personnel, such as linemen. The staff wants to shut off that piece of the supply line and fix it if there is an issue there. Because of the He can enter it into the computer system using a matrix keypad. The system then matches the entered password to the password created. In the event that the passwords match, the supply of electricity to that line will be cut. Now that the line can be repaired more securely, he can switch it on later by entering the password. Since no one can switch on the queue without the worker's consent, this ensures his security [1].

There is also a password-changing option here [2]. The 8-bit microprocessor from the 8051 family controls the entire system. In contrast to a predetermined password that is permanently burned onto the microcontroller, the password is saved in an EEPROM that is interfaced to the microcontroller. A warning light will appear on another bulb if the breaker is attempted to be opened incorrectly (for example, by entering the wrong password).

The paper by Santosh Ashok Kamble presented a circuit breaker system that uses an Android app and is password-based [3]. Here, we link the circuit to the Android application and enter the password there. The number of fatal accidents involving linemen who received electric shocks because of insufficient coordination between maintenance personnel and those working at the electric substation has significantly increased. This technology offers a remedy for the issue, ensuring that no further occurrences risk the lives of linemen. In this case, the substation provides circuit control. The circuit can be turned OFF by the lineman entering the password. Now that the repairs have been made safely, he may go back to the substation and turn the circuit on.

In their research, Deokar et al. [4] discussed the need for quick protection of electrical circuits from overload and short circuit faults that can occur in the power system. Therefore, the ECB (Electronic Circuit Breaker) was developed to protect electric circuits from short circuits and overloaded circuits. This type of circuit breaker has a shorter trip time when an abnormal condition arises than mechanical or convectional circuit breakers like the MCB (Miniature Circuit Breaker), which takes longer to trip the circuit due to its very slow action thermal bimetal lever mechanism. The ECB (Electronic Circuit Breaker) can be used to achieve a very low trip time of the circuit, protecting sensitive loads against short circuit or overload current. When a short circuit occurs, current flows through a series element with a low resistance, which the electronic circuit breaker (ECB) senses. The voltage drop across the series element and the preset voltage are then compared in the level comparator, the resultant comparator signal is supplied to the microcontroller, the operation of the MOSFET is controlled by the microcontroller, and the circuit trips immediately.

Diarah et al.'s project includes a keypad for stepping into the access code, a dynamic display unit that shows various messages at predetermined times, a door controller section that consists of an H-bridge driver integrated circuit (IC) which regulates the speed and direction of the door's generator, and an alarm system that sounds when certain conditions are met. An 8051-based microprocessor (89s51) controls the entire system [5].

A modification of the FMEA technique was presented by Marcelo E. Valdes to rank different hazard mitigation solutions according to how they affect the different hazardous tasks that they address. The goal is to offer an unbiased analytical tool for prioritising prospective investments or actions based on their estimated impact in terms of reducing facility hazards overall [6].

METHODOLOGY

To guarantee lineman safety, this project provides a solution to the issue. This project's primary goal is to give electricians a car system that will protect them from electrical injuries. The 8-bit microcontroller, a member of the Arduino family, is in complete control of the system. Here we use two microcontrollers, one is placed on a pole, and another is placed on a power distribution fuse box. RF Transmitter and sensor is interfaced with microcontroller placed on pole and RF receiver and switching circuit is interfaced with microcontroller which placed on power distribution fuse box. The Village or City consists of several overhead lines. Each line contains one main pole. The smart card swap circuit is placed on the main pole of each line. When line man or electrician swap their card on power turn off sensor placed on main pole of each line the microcontroller act and transmit signal through RF transmitter, RF receiver can receive that signal and microcontroller interfaced with RF receiver can take action to turn off power supply of this line through power distribution fuse box. When line man completes their work, he will swap their smart card to power turn on sensor then microcontroller transmit signal through RF transmitter to power distribution fuse box microcontroller through RF receiver and that microcontroller can take action to turn on power supply of this line.

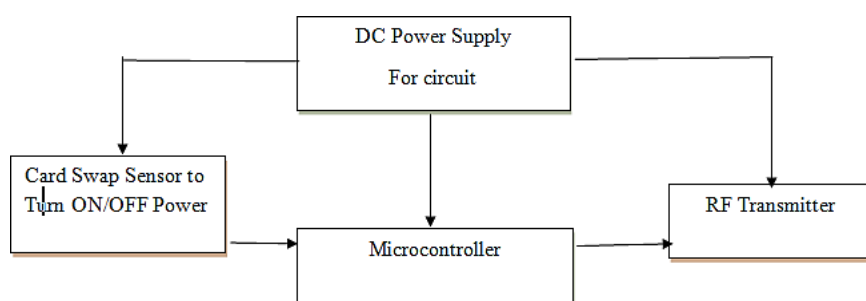

Figure 1. Placement of Electric Pole in Microcontroller.

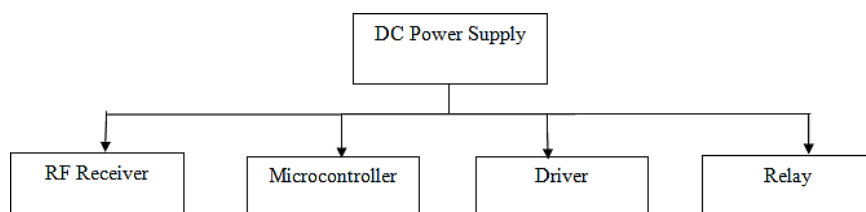

Figure 2. Placement of Circuit in Power Distribution Fuse Box.

Microcontroller Nano Arduino

To manage a single function in a gadget, a microcontroller is integrated into a system. It uses its core CPU to interpret data that it gets from its I/O peripherals to accomplish this. This system is fully controlled by 8-bit microcontroller which is family member of arduino. Here we use two microcontrollers [7–8]. One is placed on a pole, and another is placed on power distribution fuse box. Rf transmitter and sensor are interfaced with microcontroller placed on pole and rf receiver and switching circuit is interfaced with microcontroller which is placed on power distribution fuse box.

RF Transmitter

Serial data is received by the RF transmitter, which then uses its RF antenna to wirelessly send it. The data transfer rate ranges from 1 Kbps to 10 Kbps. The sent data is received by the RF receiver, which is running at the same frequency as the transmitter. As seen above, the transmitter module is made up of three pins: ground, Din, and Vcc. The input voltage range for the Vcc pin is large, ranging from 3 V to 12 V. During transmission, the transmitter's minimum current consumption is 9 mA, and it can reach up to 40 mA. The data pin used to transmit the signal is in the centre. This signal was transmitted on air at a frequency of 433 MHz after being modified using the ASK.

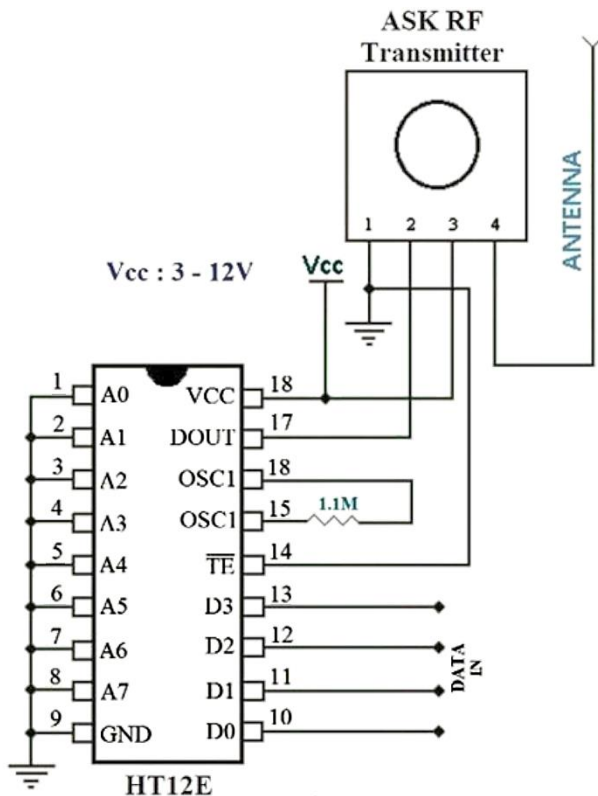

Figure 3. RF Transmitter.

RF Receiver

Receiver receives transmitted data, so data can be sent from one end to another and not the other way around. As seen above, the RF receiver module has four pins: Vcc, Dout, Linear Out, and Ground. It is necessary to use a controlled 5 V source to power the VCC pin. This module has an operating current of less than 5.5 mA. To receive the 433 MHz signal from the air, the pins Dout and Linear out are shorted together. After the data is extracted from this signal, it is demodulated and transmitted via the data pin.

LED stands for light-emitting diode, a semiconductor used in electronics that, when charged with an electric current, generates visible or infrared light. Minority electrons are delivered from $p \rightarrow n$ and minority holes are sent from $n \rightarrow p$ in a forward biased diode. Minority carrier concentration rises at the junction boundary. At the intersection, the extra minority carriers recombine with the carriers carrying the majority charges.

Transistor

A transistor is an extremely small semiconductor that acts as a gate or switching device for electrical signals and amplifies and generates them in addition to controlling or regulating the flow of current or voltage. Transistors are typically made up of three semiconductor material layers, or

terminals, each of which can carry a current. The current flowing through a different pair of transistor terminals is controlled by a voltage or current applied to one pair of terminals. A transistor can magnify a signal because the regulated (output) power can be greater than the controlling (input) power. While many transistors are found embedded in integrated circuits, some are packaged individually. It is essentially a semiconductor apparatus for power switching and signal amplification. Most electronic devices and circuits are powered by a DC power supply. Most DC power supplies are in the form of wall adapters. Transistors are among the fundamental components of contemporary electronics.

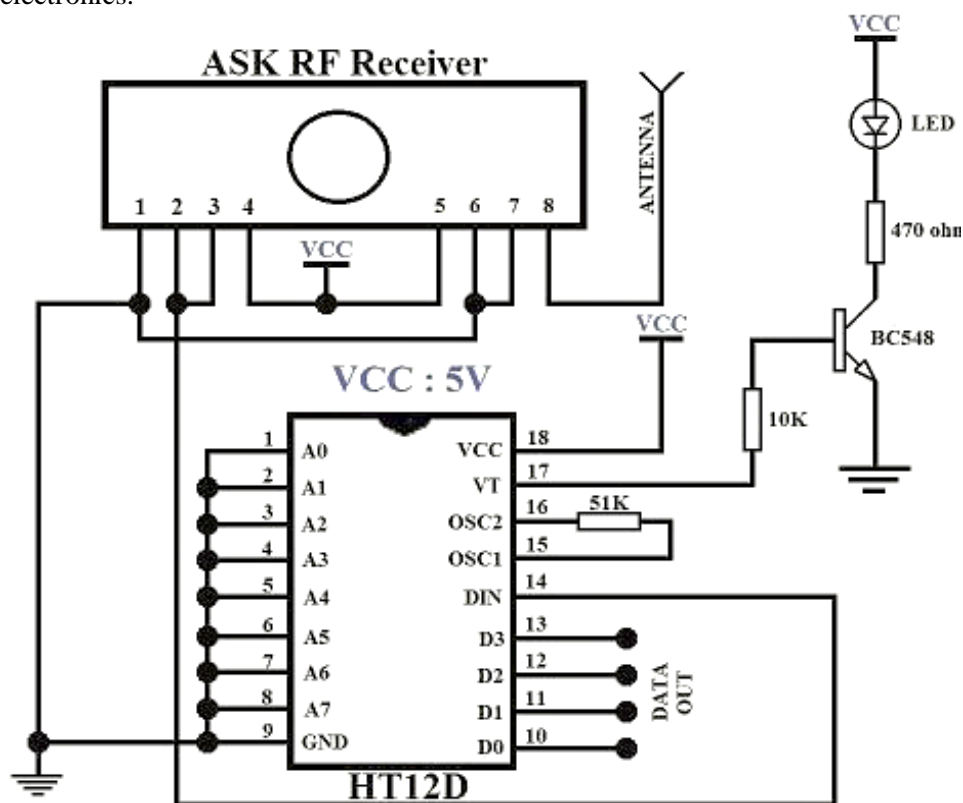

Figure 4. RF Receiver.

Power Source

An apparatus that transforms alternating current (AC) to direct current (DC) or from one voltage to another is called a direct current (DC) power supply.

Relays are electromagnetic switches that can turn on or off much greater electric currents. They are powered by relatively tiny electric currents. An electromagnet, which is a coil of wire that temporarily turns into a magnet when electricity passes through it, is the central component of a relay. Relays are used to safeguard the electrical system and reduce the risk of over currents or voltages damaging the linked equipment. Relays are used to protect the equipment that is connected to them.

Operator/Driver

A driver, which can include a high-power transistor, liquid crystal display (LCD), stepper motors, SRAM memory, and many more, is a circuit or part that is used to control another circuit or part. Typically, they are employed to control the amount of current that flows through a circuit or to manage other elements like other devices and components of the circuit. For instance, a specialised integrated circuit that manages high-power switches in switched-mode converters that convert electricity is sometimes referred to by this phrase. An amplifier can alternatively be thought of as a voltage regulator that maintains an attached component running within a wide range of input voltages or as a driver for loudspeakers.

This project gives solution to the problem to ensure line man safety. The main objective of this project is to provide an automotive system for electrician to avoid electrical injuries. Automation in electrical sector.

Acknowledgement

It's our privilege to acknowledge with a deep sense of gratitude to our project guide Prof. Sharad Patil sir for his valuable suggestions and guidance throughout our course of study and timely help given to us in completion on this paper. We express our gratitude to Prof. Sharad Patil sir (HOD, Department of Electrical Engineering) and Dr. Shivprasad Patil sir (Principal, NBNSO) for their kind help and cooperation. We are highly obliged to the entire staff of the Electrical Engineering Department for their kind co-operation and help. We also take this opportunity to thank my colleague, who backed our interest by giving useful suggestions and all possible help.

REFERENCES

1. Jay Kumar, Surya Kumar, Praveen Tyagy "PASSWORD BASED CIRCUIT BREAKER", International Journal of Recent Research Aspects. Volume 3, Issue 1, March 2016. 80–85.
2. J. Veena, Afreen, Sunil Kumar, Santhosh "Electric Lineman Protection Using User Changeable Password Based Circuit Breaker". International Journal of Current Engineering and Scientific Research (IJCESR). Volume - 2, Issue - 5, 2015.
3. Santosh Ashok Kamble. "CIRCUIT BREAKER BASED ON ANDROID", International Research Journal of Engineering and Technology. Volume: 07, Issue: 07, July 2020.
4. Tushar V. Deokar; Onkar Y. Salunkhe; Ganesh J. Ankalgi; Vishal D. Kare. Ultra-fast acting Electronic Circuit Breaker for overload protection. 2017 Third International Conference on Advances in Electrical, Electronics, Information, Communication and Bioinformatics (AEEICB). 27–28 February 2017; Chennai, India. US: IEEE Press; 2017.
5. Diarah Reuben Samuel, Egbune Dickson, Osueke Christian, "Microcontroller Based Code Locking System with Alarm", IOSR Journal of Electrical and Electronics Engineering (IOSR-JEEE). Volume 9, Issue 1 Ver. II (Jan. 2014) R. E. Mueller, Pratik Yadav, Suraj B, "Temporary protective grounding of distribution circuits," in Proc. 21st Annu. North-Amer. Power Symp., 1989, pp. 270–280.
6. M. E. Valdes, "Adapting failure mode and effects analysis (FMEA) to select hazard mitigation measures," in Conf. Rec. 59th IEEE IAS Annu. Meeting PCIC, 2014.
7. Guide for Safety in AC Substation Grounding, IEEE Std 80–2000, pp. 8, 11, and 26.
8. Ganesh Narine. Causes and Prevention of Electric Power Industry Accidents: A Delphi Study. Walden University Scholar Works. 2019. <https://core.ac.uk/download/pdf/232859067.pdf>