

## Automatic Solar Panel Cleaning Robot Using Wi-Fi

Anjali Roy<sup>1,\*</sup>, Guru Krishna Prasad S L<sup>2</sup>, Rithvin R Prasad<sup>3</sup>, Rinku R S<sup>4</sup>

### Abstract

Addressing fuel shortages stands as one of the most critical global challenges today, alongside the significant issue of water scarcity for both urban and rural populations. A considerable portion, around 60-70%, of the country's electricity demand is fulfilled by burning wood and agricultural waste. Solar energy is the most abundant renewable energy on earth which doesn't pollute the environment while producing the energy. Solar power, harnessing renewable energy from gentle solar radiation, holds immense potential. Transitioning from petroleum-based energy to electric energy is pivotal for advancing renewable sources. Solar energy has evolved into a sustainable energy choice, urging an expansion in its utilization. Particularly in dusty regions like tropical nations such as India, solar photovoltaic (PV) panels are extensively deployed. However, dust accumulation on these panels hampers their efficiency by obstructing sunlight, reducing electricity generation by up to 50% if left uncleaned for a month. The goal of this project is to argue robotic technology and WiFi connection to design, develop, and deploy a fully autonomous solar panel cleaning system. The primary aim is to tackle the decline in solar panel efficiency as a result of collecting particles. It aims to create a sophisticated cleaning robot capable of independent operation. Integrated with WiFi, the system allows remote monitoring, control, and scheduling of cleaning processes. The breakthrough is in the way wireless technologies and automated machines are seamlessly combined to improve solar panel performance and maintenance while guaranteeing peak energy production.

**Keywords:** Photovoltaic, renewable energy, robot, solar power

### INTRODUCTION

The need to optimize solar panel efficiency grows as the globe shifts toward using solar energy as its main alternate power source.

However, the accumulation of dirt and debris poses a significant challenge, diminishing the panels' performance and efficiency over time. In response to this pressing issue, we introduce the Automatic Solar Panel Cleaning Robot—a cutting-edge solution designed to ensure optimal performance and longevity of solar panel systems. Harnessing the abundance of solar energy, this innovative robot offers a proactive approach to maintaining solar panels by autonomously cleaning them at regular intervals. By employing advanced technologies such as artificial intelligence, robotics, and sensor systems, this robot is capable of efficiently navigating across solar arrays, detecting and removing various forms of contaminants, including dust, pollen, and bird droppings. Unlike traditional manual cleaning methods that are labor-intensive, time-consuming, and often impractical for large-scale installations, the Automatic Solar Panel Cleaning Robot offers a cost-effective and

#### \*Author for Correspondence

Anjali Roy  
E-mail: [anjaliroy0016@gmail.com](mailto:anjaliroy0016@gmail.com)

<sup>1</sup>Student Electrical and Electronics Engineering, UKF College of Engineering and Technology, Kollam, Kerala India

<sup>2</sup>Student Electrical and Electronics Engineering, UKF College of Engineering and Technology, Kollam, Kerala India

<sup>3</sup>Student, Electrical and Electronics Engineering, UKF College of Engineering and Technology, Kollam, Kerala India

<sup>4</sup>Assistant Professor Electrical and Electronics Engineering, UKF College of Engineering and Technology, Kollam, Kerala India

Received Date: May 20, 2024

Accepted Date: July 09, 2024

Published Date: August 24, 2024

**Citation:** Anjali Roy, Guru Krishna Prasad S L, Rithvin R Prasad, Rinku R S. Automatic Solar Panel Cleaning Robot Using Wi-Fi. Journal of Mechatronics and Automation. 2024; 11(2): 6–11p.

sustainable alternative. Because of its autonomous performance, less human intervention is required, which lowers labor costs and boosts system uptime overall. Additionally, this robot maximizes energy output by keeping solar panels clean, which boosts energy yields and increases the return on investment for solar power plants.

It also contributes to environmental sustainability by promoting the use of clean energy while reducing water consumption associated with manual cleaning methods.

A robot is developed using omni wheels that can rotate on pv panel. They have some sensors on wheels to prevent falling off. Since it is designed to be used on rooftop panels [1]. A cleaning system with or without water is developed by providing two press buttons on either side to wipe out water and nylon brush used to avoid damages to pv panel [2]. A robot with increased efficiency, reduced water usage and labor cost is developed for both cleaning and detection of other defects. It is easy to move the cleaning head so that it offers lowest risk on scratching the panels [3]. Self powered remotely controlled robot which can sense the dimension of panel and can adjust the robot is developed and cleaning is done using enviroclean liquid and drying the panel by air blow [4]. A robot which allows multidirectional motion, so it can move freely along pv panel is developed by using omni wheels results in better efficiency and reduced time for cleaning with the help of mobile application [5].

In this paper, The Automatic Solar Panel Cleaning Robot represents a breakthrough solution in the field of solar energy technology, addressing the critical issue of dirt accumulation and enabling solar panels to operate at peak efficiency. With its advanced features and benefits, this robot paves the way for a cleaner, more efficient, and sustainable future powered by solar energy [6].

#### **AUTOMATIC SOLAR PANEL CLEANING ROBOT USING WI-FI**

The existing model consists of a cleaning robot and an automated carrier track, designed to clean multiple solar panels in a solar- powered facility. The robot moves on a semicircular platform that connects to the neighboring panel, allowing it to transfer from one panel to another. It is equipped with a front-facing brush powered by a DC motor and a water line to clear the panel. The system is controlled by an Arduino microcontroller programmed in C language [7]. Additionally, the model includes a DC motor and an IR sensor for detecting changes in the environment. The IR sensor uses infrared light to track the movement of objects. The overall control of the system is depicted in a schematic diagram with a motor driver circuit and a communication module. By utilizing this model, the cleaning time can be reduced, water and power consumption can be minimized, and the cleaning process can be made more efficient [8]. By utilizing this model, the cleaning time can be reduced, water and power consumption can be minimized, and the cleaning process can be made more efficient. A potential disadvantage of a Bluetooth-based solar panel cleaning robot is its limited range. Bluetooth typically has a range of around 100 meters, which might constrain the robot's ability to receive commands or transmit data if the controlling device is far away from the solar panels [9]. This could lead to operational challenges in larger solar installations or areas with substantial distances between the control point and the cleaning robot (Figure 1).

Automatic solar panel cleaning robot using Wi-Fi works by using a combination of components and technologies. An Arduino microcontroller containing C code is in charge of operating the robot. It has a Wi-Fi module installed, permitting remote robot control [10].

The robot has a cleaning mechanism that includes a front-facing brush powered by a DC motor. A DC pump is used to bring water to the brush, which is then cleared through a water line integrated into the front panel. The robot moves on a semicircular platform that connects to the neighboring panel, and it transfers from one panel to another through connecting surfaces. The user can control the robot using a remote control that communicates with the Wi-Fi module. The remote control has buttons for moving the robot left, right, front, and back. There is also a button to activate the water pump for cleaning [11]. The brush swings to clean the solar panel's surface as the robot advances.

Overall, the Wi-Fi solar panel cleaner robot provides a wireless and automated solution for cleaning solar panels, reducing the need for manual labor and improving cleaning efficiency

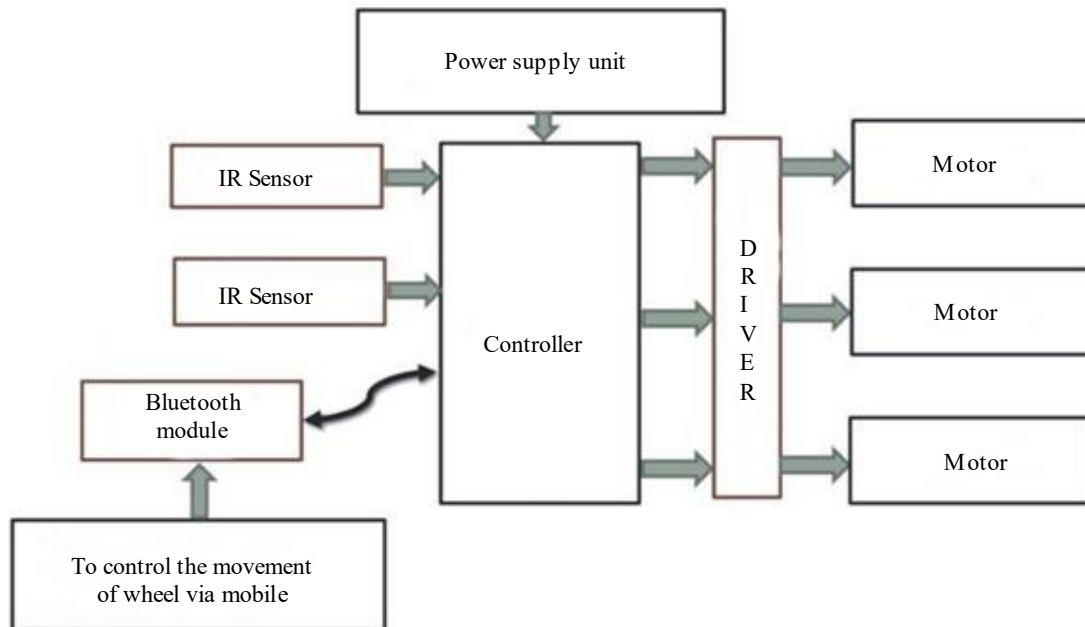

**Figure 1.** Block diagram of existing system.

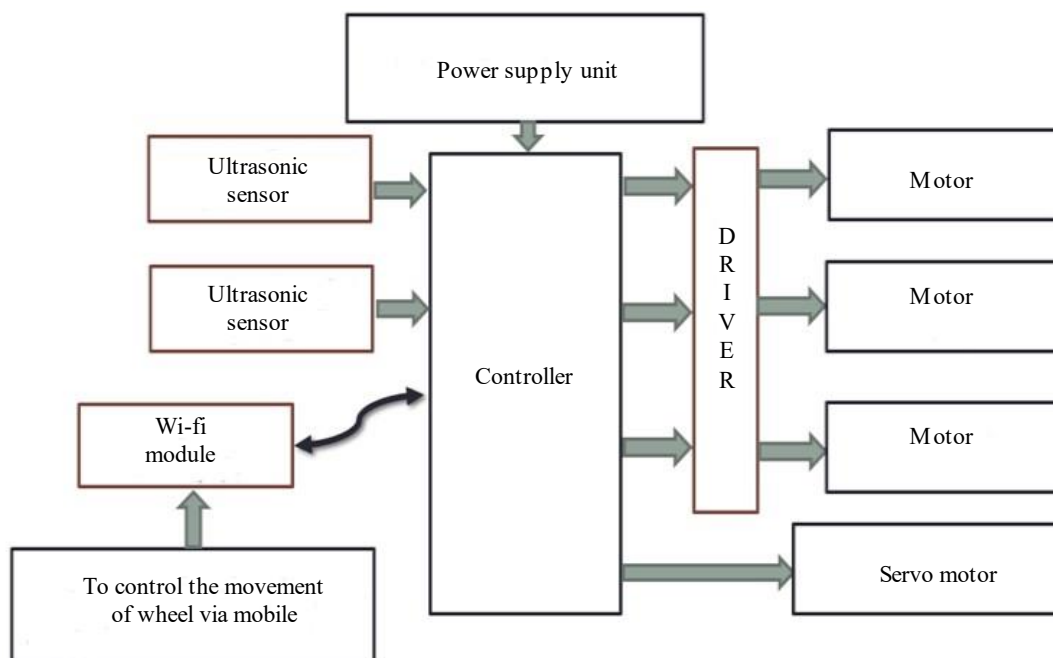

**Figure 2.** Block diagram of automatic solar panel cleaning robot using Wi-Fi.

An automatic solar panel cleaning robot that utilizes WiFi operates through a blend of advanced technologies and seamless connectivity. The robot employs sensors to detect the layout and positioning of solar panels within its operating environment. This initial detection phase is crucial as it allows the robot to create a map or grid of the solar panel array. Once the solar panels are identified, the robot autonomously navigates towards them. The cleaning mechanisms are designed to effectively remove various types of debris, including dust, dirt, pollen, bird droppings, and other contaminants that may accumulate on the panels over time [12]. The precise operation of these cleaning mechanisms ensures

thorough cleaning without causing damage to the delicate surface of the solar panels. The integration of WiFi connectivity is a pivotal aspect of the robot's functionality. The robot may link digitally to a user interface or central control center via WiFi, allowing for autonomous control and monitoring (Figure 2).

This connectivity allows operators to remotely monitor the robot's cleaning progress, receive real-time updates on its status, and intervene if necessary. Additionally, WiFi connectivity enables the robot to transmit data related to its power levels, cleaning schedule, and any encountered issues, providing valuable insights for optimization and maintenance purposes. Furthermore, WiFi connectivity facilitates the implementation of scheduled cleaning tasks based on predetermined criteria or environmental conditions. Operators can remotely adjust the cleaning schedule as needed, ensuring that the solar panels are cleaned at regular intervals to maintain peak performance and efficiency [13-17]. An automatic solar panel cleaning robot that utilizes WiFi operates through a combination of advanced technologies, including autonomous navigation, specialized cleaning mechanisms, and seamless connectivity. By leveraging WiFi connectivity, the robot can provide remote monitoring and control capabilities, optimize cleaning schedules, and facilitate efficient power management, ultimately ensuring the effective maintenance and performance of solar panel arrays [18-20].

## RESULT AND DISCUSSION

For the construction of robot, we used Arduino uno r3 ATmega328p as microcontroller, L298N as motor driver, node MCU ESP8266 as WIFI module, HC-SR04 as ultrasonic sensor (Figure 3). For the assembling of robot, we used Poly Bluetooth Controlled Omni Wheel Robot Kit (Figure 4). The assembled robot has been put in the solar panel and it has been working perfectly. The output of the solar panel increased once it is cleaned.

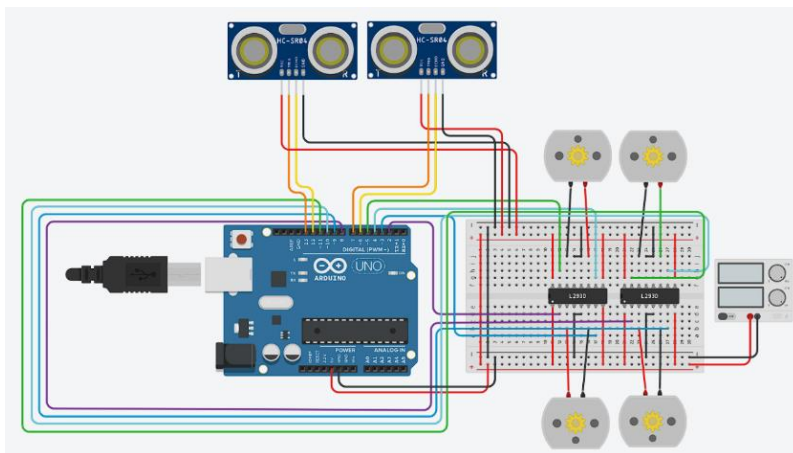

**Figure 3.** Circuit diagram of automatic solar panel cleaning robot using Wi-Fi.

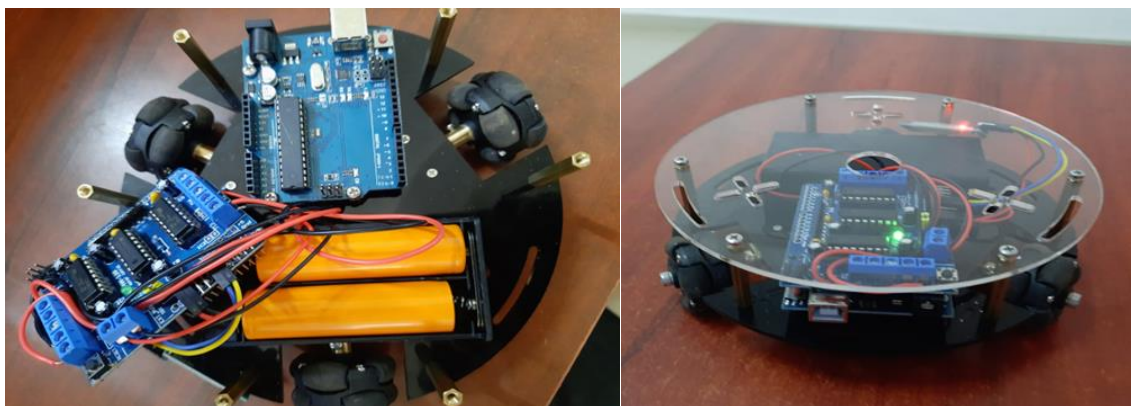

**Figure 4.** Robot trainer kit.

## CONCLUSION

The development and implementation of an automatic solar panel cleaning robot utilizing WiFi connectivity present a significant advancement in the field of renewable energy maintenance. Through the integration of intelligent design and wireless communication technology, this system offers several key advantages. Firstly, the automation of solar panel cleaning reduces the need for manual labor, thereby enhancing efficiency and minimizing operational costs. The robot may be remotely enjoyed and controlled through WiFi connectivity, allowing for real-time scheduling and improvements based on weather and energy production need.

Secondly, the autonomous nature of the robot ensures consistent and thorough cleaning, optimizing the performance of solar panels and maximizing energy output over time. This enhances the lifetime and trustworthiness of solar power systems and adds to the overall ecological sustainability of the infrastructure for renewable energy suppliers.

Overall, the automatic solar panel cleaning robot presented in this study represents a promising solution for addressing the maintenance challenges associated with solar power generation. As renewable energy continues to play a crucial role in mitigating climate change and meeting global energy demands, innovations such as this will be instrumental in enhancing the efficiency, reliability, and sustainability of solar technology. Further research and development in this area are warranted to optimize performance and expand the applicability of such systems in diverse environmental conditions.

## REFERENCES

1. T. Sorndach, N. Pudchuen and P. Srisungsitthisunti, "Rooftop Solar Panel Cleaning Robot Using Omni Wheels," *2018 2nd International Conference on Engineering Innovation (ICEI)*, Bangkok, Thailand, 2018, pp. 7-12, doi: 10.1109/ICEI18.2018.8448530.
2. S. K. Thomas, S. Joseph, T. S. Sarrop, S. B. Haris and R. Roopak, "Solar Panel Automated Cleaning (SPAC) System," *2018 International Conference on Emerging Trends and Innovations In Engineering And Technological Research (ICETIETR)*, Ernakulam, India, 2018, pp. 1-3, doi: 10.1109/ICETIETR.2018.8529032.
3. A. Al Baloushi, M. Saeed, S. Marwan, S. AlGhafri and Y. Moumouni, "Portable robot for cleaning photovoltaic system" *2018 Advances in Science and Engineering Technology International Conferences (ASET)*, Dubai, Sharjah, Abu Dhabi, United Arab Emirates, 2018, pp. 1-4, doi: 10.1109/ICASET.2018.8376781.
4. S. Santosh Kumar, S. Shankar and K. Murthy, "Solar Powered PV Panel Cleaning Robot," *2020 International Conference on Recent Trends on Electronics, Information, Communication & Technology (RTEICT)*, Bangalore, India, 2020, pp. 169-172, doi: 10.1109/RTEICT49044.2020.9315548.
5. R. Priya, K. S. Radha and M. Karthikeyan, "Design of Bluetooth-based Solar Panel Cleaner Robot," *2023 7th International Conference on Computing Methodologies and Communication (ICCMC)*, Erode, India, 2023, pp. 1611-1616, doi: 10.1109/ICCMC56507.2023.10084178.
6. M. Keennon, K. Klingebiel, and H. Won, "Development of the Nano Hummingbird: A tailless flapping wing micro air vehicle," in *Proc. 50th AIAA Aerosp. Sci. Meeting Including New Horizons Forum Aerosp. Expo.* Jan. 2012, p. 588.
7. E. Farrell Helbling and R. J. Wood, "A review of propulsion, power, and Control architectures for insect-scale flapping-wing vehicles," *Appl. Mech.Rev.*, vol. 70, no. 1, Jan. 2018, Art. No. 010801, doi: 10.1115/1.4038795.
8. M. H. Dickinson, F.-O. Lehmann, and S. P. Sane, "Wing rotation and the aerodynamic basis of insect flight," *Science*, vol. 284, no. 5422, pp. 1954–1960, 1999, doi: 10.1126/SCIENCE.284.5422.1954.
9. R. J. Wood, "The first take-off of a biologically inspired at-scale robotic Insect," *IEEE Trans. Robot.*, vol. 24, no. 2, pp. 341–347, Apr. 2008, doi:10.1109/TRO.2008.916997.

10. N. T. Jafferis, E. F. Helbling, M. Karpelson, and R. J. Wood, “Untethered Flight of an insect-sized flapping-wing microscale aerial vehicle,” *Nature*, Vol. 570, no. 7762, pp. 491–495, Jun. 2019, doi: 10.1038/s41586-019-1322-0.
11. D. Lentink and M. H. Dickinson, “Rotational accelerations stabilize leading edge vortices on revolving fly wings,” *J. Experim. Biol.*, vol. 212, No. 16, pp. 2705–2719, Aug. 2009, doi: 10.1242/JEB.022269.
12. M. Piccoli and M. Yim, “Piccolissimo: The smallest micro aerial vehicle,” In *Proc. IEEE Int. Conf. Robot. Autom. (ICRA)*, May 2017, pp. 3328–3333, Doi: 10.1109/ICRA.2017.7989378.
13. D. K.-C. Liu, J. Friend, and L. Yeo, “A brief review of actuation at the micro-scale using electrostatics, electromagnetics and piezoelectric Ultrasonic,” *Acoust. Sci. Technol.*, vol. 31, no. 2, pp. 115–123, 2010, doi:10.1250/AST.31.115.
14. T. Mashimo and S. Izuhara, “Review: Recent advances in Micromotors,” *IEEE Access*, vol. 8, pp. 213489–213501, 2020, doi:10.1109/ACCESS.2020.3041457.
15. A. Inoue, B. Shen, and A. Takeuchi, “Developments and applications of bulk glassy alloys in late transition metal base system,” *Mater. Trans.* vol. 47, no. 5, pp. 1275–1285, 2006, doi: 10.2320/MATER-TRANS.47.1275.
16. W. S. N. Trimmer, “Micro robots and micromechanical systems,” *Sens. Actuators*, vol. 19, no. 3, pp. 267–287, 1989, doi: 10.1016/02506874(89)87079-9.
17. E. Drexler, *Nano systems: Molecular Machinery, Manufacturing, and Computation*. Hoboken, NJ, USA: Wiley, 1992.
18. K. Dermitzakis, J. P. Carbajal, and J. H. Marden, “Scaling laws in Robotics,” *Proc. Compute. Sci.*, vol. 7, pp. 250–252, Jan. 2011, doi, 10.1016/j.procs.2011.09.038.
19. L.-S. Fan, Y.-C. Tai, and R. S. Müller, “IC-processed electrostatic Micromotors,” *Sens. Actuators*, vol. 20, nos. 1–2, pp. 41–47, 1989, doi:10.1016/02506874(89)87100-8.
20. S. C. Jacobsen, R. H. Price, J. E. Wood, T. H. Rytting, and M. Rafael of, “The wobble motor: Design, fabrication and testing of an eccentric-motion Electrostatic micro actuator,” in *Proc. Int. Conf. Robot. Autom.* May 1989, pp. 1536–1546, doi,10.1109/ROBOT.1989.100197.