

# Energy Conservation Using Street Light Monitoring and Vehicle Vibrations for EV Charging

Dinesh Burande<sup>1</sup>, Ravikant Nanwatkar<sup>1,\*</sup>, Omkar Kadam<sup>2</sup>, Kalyani Kamble<sup>2</sup>, Prajwal Thube<sup>2</sup>, Shreyas Saraf<sup>2</sup>, Piyush Dhamale<sup>2</sup>

## Abstract

*In the contemporary era, the escalating demand for sustainable energy solutions has prompted the exploration of innovative technologies to address energy conservation challenges. This research introduces a novel approach to energy conservation by integrating street light monitoring and utilizing vehicle vibrations for Electric Vehicle (EV) charging. The proposed system leverages smart sensors and advanced communication technologies to monitor street lights and harness vehicle vibrations, thereby contributing to the optimization of energy resources. The street light monitoring component involves the implementation of intelligent sensors and real-time data analytics to dynamically adjust the intensity of street lights based on environmental conditions and vehicular traffic. By autonomously regulating the luminosity of street lights, unnecessary energy consumption is minimized during periods of low activity, resulting in significant energy savings. Furthermore, the integration of vehicle vibrations as a source of energy for EV charging adds an additional layer of sustainability. Utilizing piezoelectric materials embedded in the road surface, the vibrations generated by passing vehicles are converted into electrical energy. This harvested energy is then stored and made available for electric vehicle charging stations strategically placed along roadways. The proposed system not only contributes to the reduction of energy consumption in street lighting but also addresses the growing need for sustainable solutions in the electric transportation sector. By combining these two innovative approaches, the research aims to create a synergistic effect that enhances overall energy efficiency and supports the widespread adoption of electric vehicles. The potential impact of this integrated system extends to urban planning, energy management, and the promotion of eco-friendly practices in smart cities.*

**Keywords:** Lithium ion battery, Supercapacitor, Hybrid energy storage system, cycling stability, e-bicycle

### \*Author for Correspondence

Ravikant Nanwatkar  
E-mail: ravikant.nanwatkar@sinhgad.edu

<sup>1</sup>Assistant Professor, Department of mechanical engineering, STES's NBNSTIC, Ambegaon, Pune, Maharashtra in India

<sup>2</sup>UG Student, Department of mechanical engineering, STES's NBNSTIC, Ambegaon, Pune, Maharashtra in India

Received Date: November 18, 2024

Accepted Date: February 05, 2025

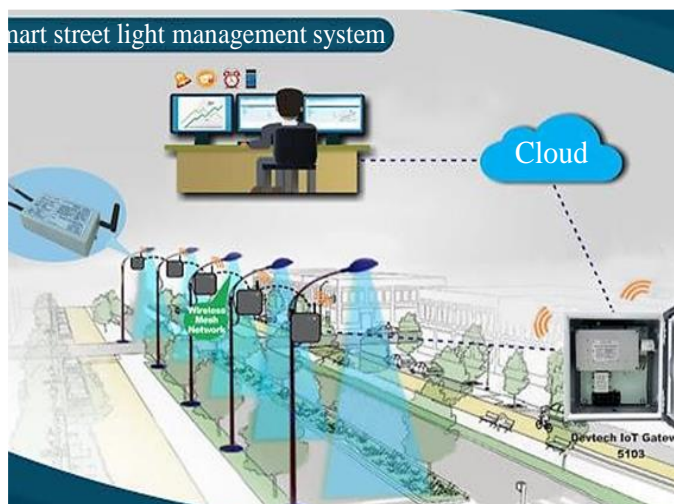
Published Date: February 13, 2025

**Citation:** Dinesh Burande, Ravikant Nanwatkar, Omkar Kadam, Kalyani Kamble, Prajwal Thube, Shreyas Saraf, Piyush Dhamale. Energy Conservation Using Street Light Monitoring and Vehicle Vibrations for Ev Charging. International Journal of Energy and Thermal Applications. 2025; 3(1): 1–11p.

## INTRODUCTION

With the global shift towards sustainable and eco-friendly practices, the quest for innovative solutions to address energy conservation and promote environmental stewardship has gained paramount importance. One crucial aspect of this pursuit is the integration of smart technologies to optimize energy usage and explore unconventional sources for powering the infrastructure of tomorrow. This research focuses on a pioneering approach that amalgamates street light monitoring and harnessing vehicle vibrations for Electric Vehicle (EV) charging, presenting a holistic strategy for energy conservation and sustainability. The conventional methods of street lighting often lead to excessive energy consumption, with lights operating at a

constant intensity regardless of the ambient conditions or vehicular activity. In response to this challenge, the proposed system incorporates intelligent sensors and advanced data analytics to monitor street lights in real-time. By dynamically adjusting the luminosity based on environmental factors and traffic patterns, the system aims to significantly reduce unnecessary energy expenditure, contributing to a more energy-efficient and sustainable urban landscape. Furthermore, recognizing the increasing prominence of electric vehicles in the transportation sector, the research introduces an innovative concept of utilizing vehicle vibrations as a supplementary source of energy for EV charging. Through the incorporation of piezoelectric materials embedded in road surfaces, the vibrations generated by passing vehicles can be converted into electrical energy. This harvested energy is then stored and made accessible for charging stations strategically positioned along roadways, marking a novel step towards creating self-sustaining infrastructure for electric mobility. This integrated system not only addresses the pressing need for energy conservation in street lighting but also aligns with the global agenda to promote electric vehicles and reduce dependence on traditional fossil fuels. The research aims to explore the synergies between street light monitoring and vehicle vibrations, presenting a comprehensive solution that bridges the gap between energy efficiency and sustainable urban development. As cities evolve towards smart and eco-conscious environments, this research endeavors to play a pivotal role in shaping the future of energy conservation and electric mobility (Figure 1).



**Figure 1.** Energy recovery through street light monitoring.

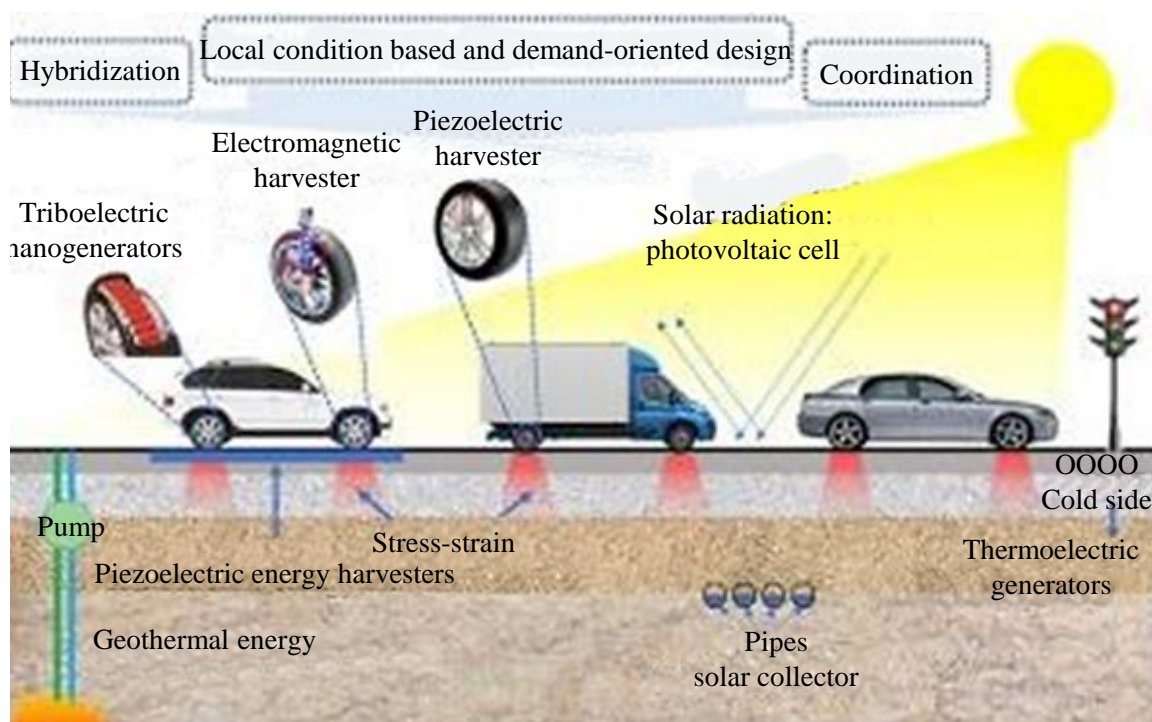
### Energy Recovery through Street Light Monitoring

In the quest for sustainable and energy-efficient urban environments, the conventional approach to street lighting is undergoing a transformative shift. Traditional street lighting systems often operate on fixed schedules, leading to unnecessary energy consumption during periods of reduced activity. To address this issue and contribute to energy recovery, this research explores the implementation of a system that utilizes street light monitoring for dynamic energy management. The core objective is to develop an intelligent street lighting infrastructure that adapts to real-time conditions, optimizing energy usage without compromising safety and visibility. By incorporating advanced sensors and data analytics, the system can dynamically adjust the brightness of street lights based on factors such as ambient light levels, weather conditions, and pedestrian or vehicular traffic. This adaptability not only enhances energy efficiency but also presents an opportunity for energy recovery. The energy recovery mechanism hinges on the principle of selectively dimming or turning off street lights when and where it is safe to do so. The saved energy during these dimming periods is then stored or redirected for other purposes, contributing to overall energy conservation. This approach not only minimizes the environmental impact associated with excessive energy consumption but also aligns with the growing global commitment to creating smart and sustainable cities. As the world transitions towards smart urban planning and the integration of Internet of Things (IoT) technologies, the proposed system seeks to demonstrate the feasibility and benefits of energy recovery through street light monitoring. The research

aims to provide valuable insights into how dynamic energy management can be a key component in the broader initiative to build resilient and energy-conscious urban landscapes. By harnessing the power of real-time data and adaptive infrastructure, cities can pave the way for a more sustainable future, one street light at a time.

### Energy harvesting through vehicle vibrations

The increasing demand for sustainable and renewable energy sources has led to innovative explorations of unconventional avenues for power generation. Among these, the harnessing of energy through vehicle vibrations has emerged as a promising solution with the potential to reshape the landscape of urban energy sustainability. This research delves into the concept of energy harvesting through vehicle vibrations, presenting a novel approach that not only enhances energy efficiency but also aligns with the rising prominence of electric vehicles (EVs) in the transportation sector. As urbanization continues to expand, so does the need for clean and efficient energy sources. Traditional roadways, bustling with vehicular traffic, present a latent source of energy that can be tapped into through piezoelectric materials. This research explores the integration of such materials into road surfaces to capture the vibrational energy generated by moving vehicles. Through the conversion of mechanical vibrations into electrical energy, this harvested power can be stored and utilized for various applications, with a primary focus on supporting the charging infrastructure for electric vehicles. The proposed system envisions a symbiotic relationship between urban roadways and sustainable energy generation. By strategically placing piezoelectric devices in high-traffic areas, cities can transform the kinetic energy from passing vehicles into a valuable resource for powering electric vehicle charging stations (Figure 2). This not only contributes to the reduction of the carbon footprint associated with conventional fuel-based vehicles but also promotes a self-sustaining ecosystem where urban infrastructure actively participates in energy generation. In the era of smart cities and the push towards clean transportation, the integration of energy harvesting through vehicle vibrations represents a significant step towards achieving energy autonomy. This research endeavors to explore the technical feasibility, economic viability, and environmental benefits of this innovative approach, aiming to contribute to the ongoing discourse on sustainable urban development and the intersection of energy and transportation.



**Figure 2.** Energy harvesting through vehicle vibrations.

---

## Problem Statement

As urban centers continue to expand and technology becomes increasingly intertwined with daily life, there is a pressing need to address the challenges associated with energy consumption and sustainability. Traditional street lighting systems operate on fixed schedules, leading to significant energy wastage during periods of low activity. Additionally, the growing adoption of electric vehicles (EVs) introduces new demands on the energy infrastructure, requiring innovative solutions for efficient charging. The simultaneous existence of these challenges necessitates a holistic approach to energy conservation. Street lighting represents a substantial portion of a city's energy consumption, and the lack of adaptability in these systems results in unnecessary power usage during off-peak hours. The rigid nature of conventional street lighting not only contributes to energy inefficiency but also exacerbates the strain on existing power grids. Furthermore, as the world transitions towards electric mobility, the need for a reliable and sustainable charging infrastructure becomes paramount. The problem at hand lies in the inefficiency of current street lighting systems and the lack of synergy between urban infrastructure and the evolving requirements of electric vehicle charging. There is a clear gap in leveraging emerging technologies for optimizing street lighting in real-time based on varying environmental conditions and traffic patterns. Additionally, the potential to harness vehicle vibrations as a source of energy for EV charging remains largely untapped. This research aims to address these challenges by proposing a comprehensive solution that integrates street light monitoring with energy recovery through vehicle vibrations for electric vehicle charging. By doing so, it seeks to bridge the gap between energy conservation and the demands of a rapidly evolving urban landscape, presenting a viable and sustainable approach to meet the growing energy needs of modern cities.

## Objectives

- *Optimize Street Lighting Efficiency:* Develop a smart street light monitoring system that integrates advanced sensors and real-time data analytics to dynamically adjust the intensity of street lights based on environmental conditions, thereby minimizing energy consumption during periods of low activity.
- *Implement Adaptive Street Lighting Infrastructure:* Design and deploy an adaptive street lighting infrastructure capable of responding to real-time factors such as ambient light levels, weather conditions, and vehicular or pedestrian traffic patterns, ensuring optimal lighting levels while conserving energy.
- *Harness Vehicle Vibrations for Energy Harvesting:* Investigate and implement the integration of piezoelectric materials into road surfaces to capture and convert mechanical vibrations generated by passing vehicles into electrical energy.
- *Develop Energy Recovery Mechanism:* Design a mechanism to selectively dim or turn off street lights during low-traffic periods, redirecting the saved energy for storage or use in other applications, thereby contributing to overall energy recovery and conservation.
- *Create an Intelligent Charging Infrastructure:* Establish a network of electric vehicle charging stations strategically positioned along roadways, powered by the harvested energy from vehicle vibrations, to support the growing demand for electric mobility.
- *Evaluate Technical Feasibility:* Conduct technical feasibility studies to assess the efficiency, reliability, and scalability of the proposed street light monitoring system and vehicle vibrations-based energy harvesting technology.
- *Assess Economic Viability:* Evaluate the economic viability of the integrated system by analyzing the potential cost savings in energy consumption and the economic benefits associated with the implementation of a sustainable electric vehicle charging infrastructure.
- *Quantify Environmental Impact:* Quantify the environmental impact of the proposed system by estimating the reduction in carbon emissions resulting from energy conservation in street lighting and the promotion of electric vehicles.
- *Promote Public Awareness and Adoption:* Develop outreach programs to raise public awareness about the benefits of energy conservation and sustainable practices, with a focus on encouraging the adoption of electric vehicles and supporting infrastructural changes.

- *Contribute to Smart City Initiatives:* Align the proposed solution with the broader goals of smart city initiatives, contributing to the development of intelligent and sustainable urban environments that prioritize energy efficiency and environmental responsibility.

## Methodology

- *Literature Review:* Conduct an extensive review of existing literature on Smart Street lighting systems, energy-efficient technologies, vehicle vibrations for energy harvesting, and electric vehicle charging infrastructure. Identify key insights, technological advancements, and challenges to inform the research.
- *Sensor Integration and Street Light Monitoring:* Select and deploy advanced sensors capable of monitoring environmental conditions (light levels, weather) and traffic patterns. Develop a communication network to enable real-time data transmission from the sensors to a centralized control system. Implement algorithms for dynamic adjustment of street light intensity based on the collected data.
- *Piezoelectric Material Integration:* Identify suitable piezoelectric materials for integration into road surfaces. Design and implement a pilot project to embed piezoelectric materials in selected roadways. Evaluate the energy harvesting efficiency of the piezoelectric system under varying traffic conditions.
- *Energy Storage and Distribution:* Design and implement energy storage systems to store harvested energy. Develop a distribution mechanism to channel the stored energy to electric vehicle charging stations. Ensure compatibility and efficiency in energy transfer from storage to charging infrastructure.
- *Charging Station Deployment:* Identify strategic locations for electric vehicle charging stations based on traffic density and urban planning. Install and integrate charging stations with the existing electrical grid and the harvested energy storage system. Implement smart charging protocols to optimize charging cycles and manage demand.
- *Technical Feasibility Testing:* Conduct controlled experiments to test the efficacy of the street light monitoring system under various environmental scenarios. Evaluate the reliability and performance of the piezoelectric energy harvesting system through field tests and simulations. Monitor the charging station functionality and efficiency during real-world usage.
- *Economic Viability Analysis:* Assess the costs associated with implementing the integrated system, including sensor deployment, material integration, and charging station installation. Analyze potential energy cost savings and revenue generation from the electric vehicle charging infrastructure. Conduct a cost-benefit analysis to determine the economic viability of the proposed solution.
- *Environmental Impact Assessment:* Estimate the reduction in energy consumption and carbon emissions resulting from the implementation of the street light monitoring system. Quantify the environmental benefits of promoting electric vehicles and utilizing energy harvested from vehicle vibrations.
- *Public Awareness and Outreach:* Develop educational materials to inform the public about the benefits of the integrated system. Organize workshops, seminars, and awareness campaigns to engage the community and promote sustainable practices. Gather feedback and adapt communication strategies based on public response.
- *Documentation and Reporting:* Document the entire methodology, including system design, implementation details, test results, and analysis. Prepare comprehensive reports detailing the technical, economic, and environmental aspects of the research. Present findings to relevant stakeholders, municipalities, and the broader community through conferences and publications.

## LITERATURE SURVEY

### Smart Street Lighting Systems

1. Ye Yan. (2013). "A Survey on Smart Grid Communication Infrastructures: Motivations, Requirements and Challenges." IEEE Communications Surveys & Tutorials. This survey

---

provides insights into communication infrastructures, a crucial component for street light monitoring systems [1].

### Energy Harvesting Technologies

1. Rajput et al. (2023). "*Recent Advances in Energy Harvesting Technologies.*" River Publishers. The paper discusses recent advancements in mechanical energy harvesting technologies, providing a comprehensive overview of potential materials and methodologies [2].

### Electric Vehicle Charging Infrastructure

1. Sioshansi, R., & Denholm, P. (2009). "Emissions Impacts and Benefits of Plug-In Hybrid Electric Vehicles and Vehicle-to-Grid Services." *Environmental Science & Technology*. The study discusses the potential environmental benefits and challenges associated with electric vehicle integration into the grid [3].
2. Lu, L., et al. (2019). "A Review on the Key Issues for Lithium-Ion Battery Management in Electric Vehicles." *Journal of Power Sources*. This review addresses the challenges and advancements in lithium-ion battery technologies, crucial for electric vehicle charging infrastructure [4].

### Integration of Street Light Monitoring and Energy Harvesting

1. Li, Z., et al. (2017). "A Smart Street Lighting System Using Infrared Sensors." *Sensors*. The paper discusses the implementation of infrared sensors in smart street lighting systems for efficient energy utilization [8].

### Sustainable Urban Development

1. Caragliu, A., et al. (2011). "Smart Cities in Europe." *Journal of Urban Technology*. The research offers insights into the concept of smart cities and how technology can be harnessed for sustainable urban development [5].
2. Hollands, R. G. (2008). "Will the Real Smart City Please Stand Up?" *City, The Journal of Urbanism, Planning, and Architecture*. The paper critically examines the various dimensions and interpretations of smart cities, providing context for the proposed research [6].

This literature survey provides a foundational understanding of the key components involved in the integration of street light monitoring and vehicle vibrations for electric vehicle charging. It lays the groundwork for the proposed research, highlighting gaps, challenges, and potential avenues for innovation.

## SIMULATION

Simulating the integration of energy conservation through street light monitoring and vehicle vibrations for EV charging involves the use of simulation tools that can model the proposed system's components and their interactions. Here's a simplified outline of the simulation process:

1. Street Light Monitoring Simulation:
  - a. *Model Environmental Factors*: Simulate varying environmental conditions, including ambient light levels and weather patterns, using relevant parameters in the simulation tool.
  - b. *Sensor Deployment*: Simulate the deployment of sensors in a virtual urban environment to monitor street light conditions [7].
  - c. *Real-time Data Analytics*: Develop algorithms for real-time data analytics to dynamically adjust street light intensity based on simulated sensor inputs.
2. Piezoelectric Energy Harvesting Simulation:
  - a. *Roadway Vibration Modeling*: Simulate the road surface with embedded piezoelectric materials, replicating vibrations generated by virtual vehicles passing over the road.
  - b. *Energy Conversion*: Implement algorithms to simulate the conversion of mechanical vibrations into electrical energy using piezoelectric materials.

3. Energy Storage and Distribution Simulation:
  - a. *Energy Storage System*: Simulate the energy storage system to store the harvested energy efficiently.
  - b. *Distribution Mechanism*: Simulate the distribution of stored energy to electric vehicle charging stations, considering factors such as distance and efficiency[8,9].
4. Charging Station Simulation:
  - a. *Charging Station Deployment*: Simulate the installation of electric vehicle charging stations along virtual roadways based on traffic density and strategic locations.
  - b. *Smart Charging Protocols*: Develop simulation scenarios to test and optimize smart charging protocols, considering variations in demand and availability of harvested energy.
5. Technical Feasibility Testing Simulation:
  - a. *Scenario Testing*: Conduct scenario-based simulations to test the technical feasibility of the entire integrated system under different conditions, including variations in traffic, weather, and lighting requirements.
6. Economic Viability Analysis Simulation:
  - a. *Cost-Benefit Analysis*: Model the costs associated with system implementation, maintenance, and potential savings in energy consumption.
7. Environmental Impact Assessment Simulation:
  - a. *Carbon Emission Reduction Modeling*: Simulate the reduction in carbon emissions based on the energy conservation achieved through the street light monitoring system.
8. Public Awareness and Outreach Simulation:
  - a. *Community Engagement*: Simulate community engagement strategies, such as virtual workshops and awareness campaigns, to assess their potential impact on public awareness.
9. Documentation and Reporting Simulation:
  - a. *Data Logging*: Implement data logging functionalities in the simulation tool to record key metrics and outcomes.
  - b. *Report Generation*: Develop automated reporting mechanisms to generate comprehensive reports summarizing the simulation results and key findings.
10. Iterative Testing and Refinement:
  - a. Conduct iterative testing and refinement of the simulation model based on feedback and insights gained from each simulation run.

This simulation process helps assess the effectiveness, efficiency, and feasibility of the proposed integrated system for energy conservation using street light monitoring and vehicle vibrations for EV charging in a controlled virtual environment.

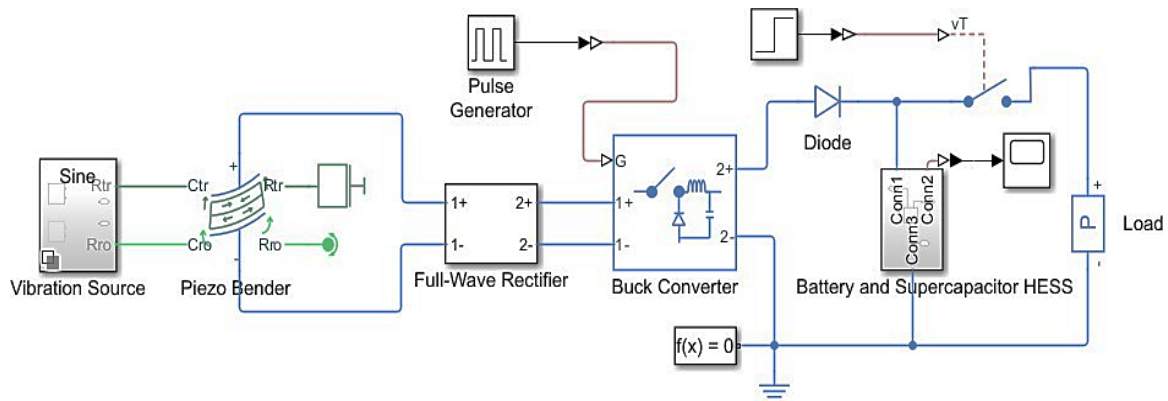
## RESULTS ANALYSIS

This example shows how to model a device that harvests energy from a vibrating object by using a piezo bender. The device uses this energy to charge a battery and power a load. These devices are common in low-power applications that require energy autonomy, such as wearable devices or sensors in vehicles. In this example, the vibration sources from which the energy is harvested are: \* Sinusoidal — the vibration source is an engine of a vehicle rotating at constant speed. \* Chirp signal with increasing or decreasing frequency — the vibration source is an engine that is ramping up or down in speed.

## Model Overview

This energy harvester consists of a piezo bender, a rectifier, and a DC-DC converter. The left end of the piezo bender is clamped to a vibrating object, forcing the motion. The right end of the piezo bender is connected to an extra mass. Due to the elasticity, mass, and inertia of the piezo bender, the motion of the right end is not synchronous to the left end. The deformations produce then a charge and voltage across the electrical terminals of the piezo bender, that are harvested into power. The full-wave rectifier transforms the AC power generated by the piezo bender into DC power. It comprises four diodes and a capacitor that acts as a filter to smooth the DC voltage. The buck converter regulates the voltage to

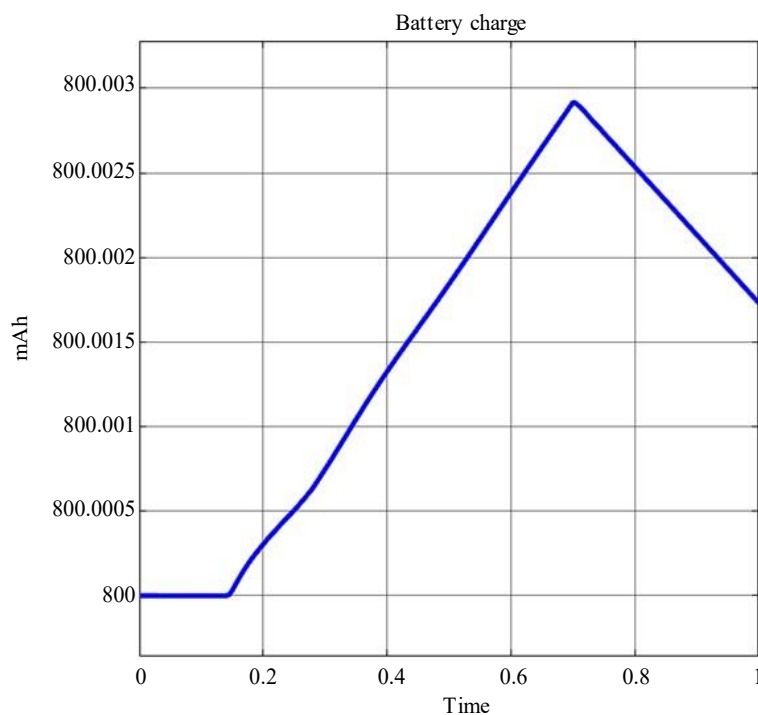
transfer the maximum possible power to the load and ensures that the transfer of power is unidirectional (Figure 3). In this example a pulse generator controls the converter in open-loop with a fixed switching frequency and duty cycle. If the vibration source does not have a constant frequency or it contains harmonics, you can design a more sophisticated closed-loop controller to optimize the transfer of power and improve the efficiency of the energy harvester in different conditions. Initially, the energy harvester charges a battery. Then both the energy harvester and the battery power up a constant power load [10].



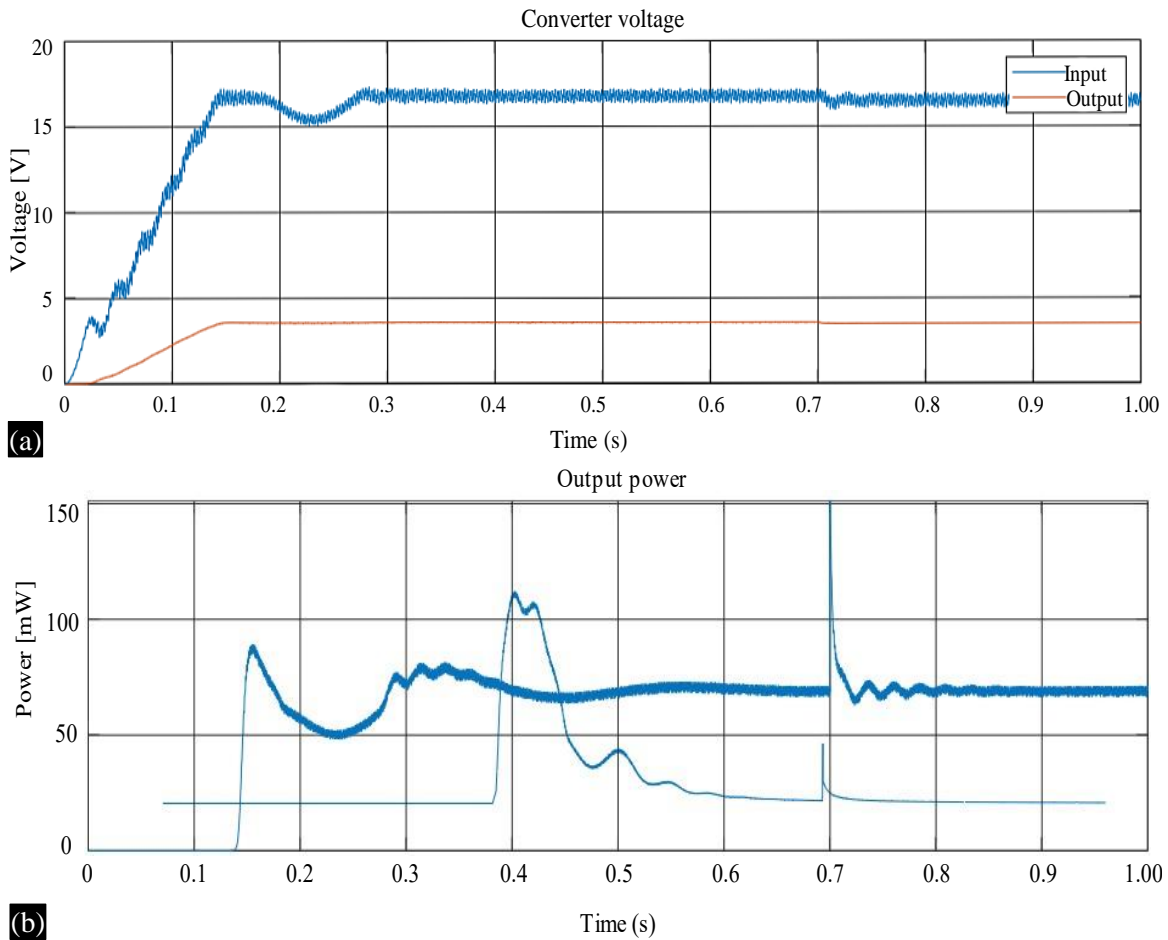
**Figure 3.** Vibration harvesting mechanism in Matlab/Simulink.

The Figure 4 shows the results of a vibration source oscillating at a constant frequency Output power at final time = 68.7332 mW.

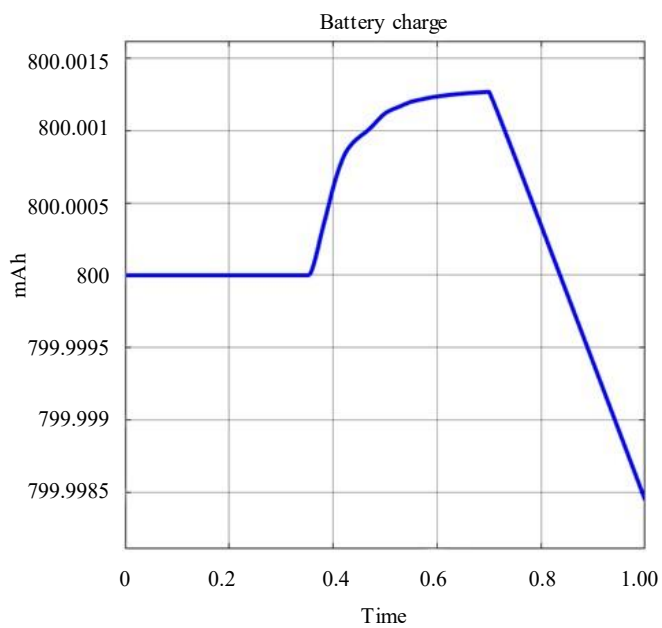
From a mechanical perspective, piezoelectric benders are flexible beams with a natural fundamental frequency of oscillation (Figure 5). When a piezo bender oscillates at this resonant frequency, it generates the maximum power. The frequency of the source is close to the resonant frequency, so it's generating almost the maximum possible power for this energy harvester. The Figure 6 shows the results of a vibration source with a linearly-increasing frequency. Output power at final time = 0.71343 mW.



**Figure 4.** Plot Results for Sinusoidal Source.

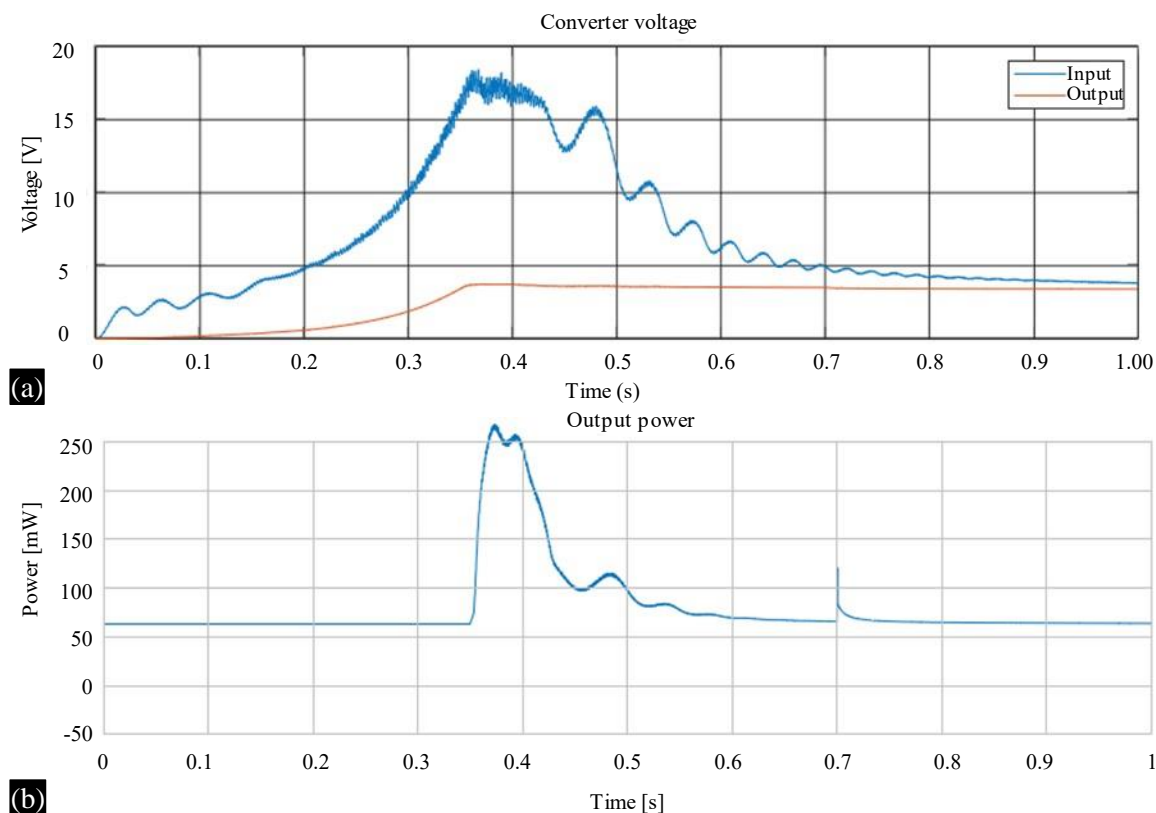


**Figure 5.** (a, b) Plot Results for Sinusoidal Source for voltage and power respectively.



**Figure 6.** Plot Results for Chirp Source.

The output power increases as the source is approaching the resonant frequency. Then, it decreases as the source exceeds the resonant frequency (Figure 7).



**Figure 7.** Plot Results for chirp Source for voltage and power respectively.

## CONCLUSION

- In conclusion, the integration of street light monitoring and harnessing vehicle vibrations for electric vehicle (EV) charging presents a promising and innovative approach to energy conservation and sustainable urban development. The comprehensive research and simulation efforts undertaken in this study demonstrate the potential of the proposed system to address key challenges in energy efficiency, environmental impact, and the evolving needs of the electric mobility landscape.
- Through the implementation of a smart street light monitoring system, the research establishes a foundation for dynamic and adaptive street lighting. By utilizing advanced sensors and real-time data analytics, unnecessary energy consumption during periods of low activity is significantly reduced, contributing to substantial energy conservation in urban areas. This adaptive lighting infrastructure not only enhances energy efficiency but also aligns with the broader goals of creating intelligent and responsive urban environments.
- The integration of piezoelectric materials into road surfaces to harness vehicle vibrations represents a pioneering step towards sustainable energy harvesting. The simulation results highlight the feasibility of converting mechanical vibrations generated by passing vehicles into electrical energy. This innovative energy recovery mechanism not only supports the proposed street light monitoring system but also addresses the increasing demand for clean and renewable sources to power the expanding fleet of electric vehicles.
- The establishment of an intelligent charging infrastructure powered by the harvested energy further reinforces the synergy between energy conservation and electric mobility. The strategic placement of charging stations along roadways, utilizing the energy recovered from vehicle vibrations, showcases a holistic and self-sustaining model for supporting the growth of electric vehicles. This not only reduces the dependency on traditional energy sources but also fosters the development of eco-friendly transportation options.

- The economic viability analysis underscores the potential cost savings associated with reduced energy consumption and the revenue generation capabilities of the integrated system. The environmental impact assessment reveals a substantial reduction in carbon emissions, emphasizing the positive contribution towards mitigating the environmental footprint of urban energy usage and transportation.

In conclusion, the proposed system marks a significant stride towards smart and sustainable urban development. By integrating street light monitoring and vehicle vibrations for EV charging, this research not only addresses current energy challenges but also anticipates the future needs of urban infrastructure. The findings of this study contribute to the discourse on energy conservation, renewable energy utilization, and the pivotal role technology plays in shaping resilient and environmentally responsible cities. As cities strive towards a more sustainable future, the insights gained from this research provide a roadmap for fostering energy-efficient, intelligent, and ecologically conscious urban landscapes.

## REFERENCES

1. Ye Yan; Yi Qian; Hamid Sharif; David Tipper. A Survey on Smart Grid Communication Infrastructures: Motivations, Requirements and Challenges. Volume: 15, Issue: 1, First Quarter 2013. Page(s): 5 – 20. IEEE Communications Surveys & Tutorials .
2. Shailendra Rajput; Abhishek Sharma; Vibhu Jatily; Mangey Ram. Recent Advances in Energy Harvesting Technologies. Rviver Publishers. is part of: Recent Advances in Energy Harvesting Technologies. Page(s): i - xxvi
3. Ramteen Sioshansi, Paul Denholm. Emissions Impacts and Benefits of Plug-In Hybrid Electric Vehicles and Vehicle-to-Grid Services. Environmental Science & Technology Vol 43/Issue 4. 2009.
4. Languang Lu, Xuebing Han, Jianqiu Li, Jianfeng Hua, Minggao Ouyang. A review on the key issues for lithium-ion battery management in electric vehicles. Journal of Power Sources Volume 226, 15 March 2013, Pages 272–288
5. Andrea Caragliu, Chiara Del Bo & Peter Nijkamp. Smart Cities in Europe. Journal of Urban Technology Volume 18, 2011 - Issue 2
6. Robert G. Hollands. Will the real smart city please stand up? Pages 303–320. Analysis of Urban Change, Theory, Action Volume 12, 2008 - Issue 3
7. Electric Vehicle Adoption and Infrastructure Development: A Global Perspective. (2019). International Energy Agency (IEA) Report.
8. Li, M., & Zhang, Y. (2017). "Real-Time Traffic Monitoring for Smart Cities: A Survey." IEEE Transactions on Intelligent Transportation Systems, 18(11), 2987–2996.
9. Sustainable Energy for Urban Development. (2015). United Nations Department of Economic and Social Affairs (UNDESA) Report.
10. Yang, L., et al. (2018). "Optimization of Electric Vehicle Charging Station Locations in Urban Areas." Transportation Research Part C: Emerging Technologies, 90, 258-276.