

Laser Engraving Machine

Shruti Mojad^{1,*}, Sanika Khapare¹, Surbhi Deshmane¹, Rajesh Rehpade²

Abstract

Laser engraving technology has gained significant importance across various sectors, including manufacturing and prototyping, as well as in the arts, due to its high precision and adaptability. Nevertheless, the high cost of commercial laser engraving systems often renders them inaccessible to small-scale users and educational institutions. From quick prototyping and large-scale production to creative industries like arts and crafts, laser engraving technology has become a very useful tool in many different domains. The technology's capacity to produce complex designs and patterns on a range of materials with high degrees of precision, accuracy, and adaptability is largely responsible for its appeal. Despite these benefits, laser engraving devices have not yet become widely used since commercial systems are very expensive. The goal of the current project is to design and create a laser engraving machine that is economical, small, and effective in order to solve this problem. The main goal is to develop a system that keeps the key features of commercial engravers while drastically cutting costs, making the technology more affordable and useful for regular people. Because of its open-source nature, ease of programming, and widespread availability in the maker and academic communities, the Arduino UNO microcontroller is used as the main control unit. Due to these exorbitant costs, small-scale users, hobbyists, start-up companies, and educational institutions frequently cannot afford or obtain such equipment, which limits their ability to innovate and gain hands-on experience. This project aims to design and develop an affordable and compact laser engraving machine, utilizing the Arduino UNO as the primary control unit. The goal is to establish a functional, user-friendly, and customizable engraving system tailored for hobbyists, students, and small enterprises. The proposed solution incorporates open-source hardware and software, such as Arduino UNO, GRBL firmware, stepper motors, and a laser module, to execute accurate engraving operations on wood.

Keywords: Engraving, LaserGRBL, InkScape, Arduino UNO, G-code

INTRODUCTION

Laser engraving represents an advanced technology that employs a precisely focused laser beam to meticulously remove material from the surface, thereby producing detailed patterns, text, or images.

This non-contact technique is extensively utilized across various sectors, including manufacturing, prototyping, personalized product design, and the arts and crafts domain, owing to its adaptability and precision. Nevertheless, conventional laser engraving machines tend to be costly and cumbersome, rendering them less accessible to individuals, small enterprises, and educational institutions. The current project presents the design and development of an affordable, small, and easy-to-use laser engraving machine based on the Arduino UNO platform in order to address these issues. An inexpensive microcontroller board with a reputation for dependability, simplicity, and broad open-source support, the Arduino UNO is a great option for educational and prototyping projects. In

*Author for Correspondence

Shruti Mojad

E-mail: shrutimojad2915@gmail.com

¹Student, Department of Electronics and Telecommunication Engineering, Mumbai Educational Trust Institute of Engineering, Bhujbal Knowledge City Adgaon, Nashik, Maharashtra, India

²Professor, Department of Electronics and Telecommunication Engineering, Mumbai Educational Trust Institute of Engineering, Bhujbal Knowledge City Adgaon, Nashik, Maharashtra, India

Received Date: September 01, 2025

Accepted Date: September 13, 2025

Published Date: November 12, 2025

Citation: Shruti Mojad, Sanika Khapare, Surbhi Deshmane, Rajesh Rehpade. Laser Engraving Machine. International Journal of Electronics Automation. 2025; 3(2): 6–13p.

order to ensure that users can complete engraving jobs without the need for pricey commercial equipment, the suggested solution aims to balance affordability and usefulness. In response to the demand for a more economical and compact alternative, this project aims to create a laser engraving machine driven by the Arduino UNO, a popular microcontroller platform recognized for its user-friendliness, affordability, and robust open-source community support [1, 2].

The laser engraving machine outlined in this study effectively merges cost-effectiveness with functionality by utilizing commonly accessible components, including stepper motors for accurate motion control, a laser module for the engraving process, and GRBL firmware for the interpretation of G-code commands. The Arduino UNO functions as the central control unit, facilitating the smooth integration of hardware components while offering users both flexibility and user-friendliness. Open-source software such as LaserGRBL is utilized for G-code generation, empowering users to produce intricate engraving designs with minimal technical knowledge [3, 4].

LITERATURE REVIEW

By examining its process characteristics, applications, and control approaches, a number of researchers have made major contributions to the progress of laser engraving technology. Numerous process factors, including laser power, scanning depth, and laser frequency, have been studied in relation to crucial performance indicators, such as surface roughness, engraving depth, and material removal rate (MRR). These studies have shed important light on how optimizing parameters might raise the effectiveness and caliber of laser engraving procedures. Furthermore, a variety of laser types used in fiber laser engraving systems have been covered, emphasizing the adaptability of available laser sources for a range of applications. These include carbon dioxide (CO₂) lasers, neodymium-doped yttrium aluminium garnet (Nd:YAG) lasers, and semiconductor lasers [5–7].

The limits of traditional industrial laser engravers, which are usually limited to flat, two-dimensional surfaces, have been the subject of other studies. By using three-dimensional laser measurement systems, creative methods have been put forth to expand engraving capabilities to curved and inclined surfaces. These techniques frequently employ two different laser regimes: a high-peak power laser for material processing and a low-power continuous wave (CW) laser for measuring and projecting the workpiece's three-dimensional shape. Since autonomous projection guarantees flawless alignment and processing, this dual-regime technology does not require precise pre-positioning or orientation of the workpiece [8]. This development created new opportunities for engraving on irregular surfaces and complex geometries, which are becoming more and more popular in contemporary production. The creation of customized computer numerical control (CNC) systems for laser engraving applications has been the subject of more research. Keeping the impulse frequency within a predetermined and constant range is one of the fundamental difficulties in material processing with impulse laser emissions. Waiting for impulse confirmation is a common component of traditional control strategies, which can be used in typical numerical control systems but may result in inefficiencies. Improved CNC techniques have been proposed to maximize impulse control, which will increase laser engraving processes' accuracy, consistency, and dependability [9]. The workpiece's shape can be automatically projected thanks to the low-power laser regime, which does away with the necessity for exact orientation or positioning before processing. Additionally, research has concentrated on creating specialized CNC systems for laser engraving applications. Maintaining the impulse frequency within a specific and steady range is one of the key difficulties in material processing with impulse laser emission. For reliable energy transmission and excellent engraving results, this parameter is essential. Standard numerical control systems can use conventional control techniques, which usually entail waiting for impulse confirmation. Nevertheless, these techniques sometimes introduce inefficiencies and restrict system responsiveness. Improved CNC architectures and control strategies have been put forth to overcome these constraints, providing increased precision, stability, and adaptability for sophisticated laser engraving processes [10].

METHODOLOGY

The Laser Engraving Machine is developed through a four-step process:

1. Transforming the chosen image into G-code,
2. Programming the Arduino to facilitate the engraving function,
3. Utilizing InkScape software to design the shapes intended for cutting on the interface, and
4. Configuring the machine setup to initiate the engraving process.

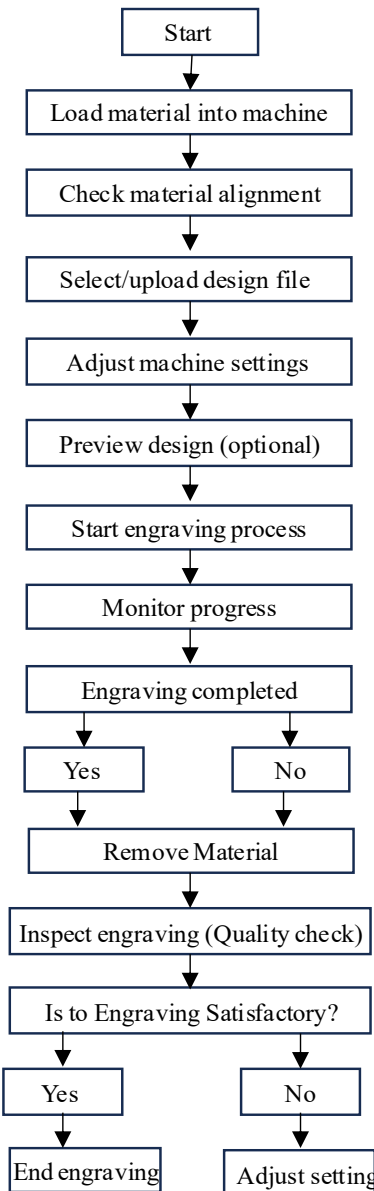

Figure 1. Flow chart of the proposed system working.

During the engraving operation, a laser beam is directed onto the wooden surface, which absorbs the light and converts it into heat. This concentrated heat causes localized burning of the wood, resulting in a cavity that outlines the design. The engraving's depth, size, and darkness can be manipulated by adjusting the laser's speed, power, and focus.

System Design

1. *Prepare material:* Position the material intended for engraving within the machine's designated work area.
2. *Verify alignment:* Confirm that the material is properly aligned to correspond with the design layout.

3. *Choose/upload design file*: Select or upload the design intended for engraving.
4. *Modify machine settings*: Adjust parameters such as speed, power, and resolution according to the material type and the required engraving depth.
5. *Design preview (optional)*: Conduct a test run to verify the layout on the material.
6. *Initiate engraving process*: Commence the actual engraving operation.
7. *Observe progress*: Monitor the engraving process to prevent issues such as overheating or misalignment.
8. *Completion of engraving*: Verify that the engraving process has been completed.
9. *Extract material*: Gently remove the engraved material from the machine.
10. *Evaluate engraving*: Assess the quality of the engraving to ensure it meets the required standards.
11. *Conclusion*: If the results are satisfactory, the process is concluded. If modifications are necessary, adjust the settings and repeat the process as needed.

Overall, Figure 1 shows the flow of the system design and working.

Block Diagram

Figure 2 shows the block diagram of the Laser engraving machine, which shows the utilized components.

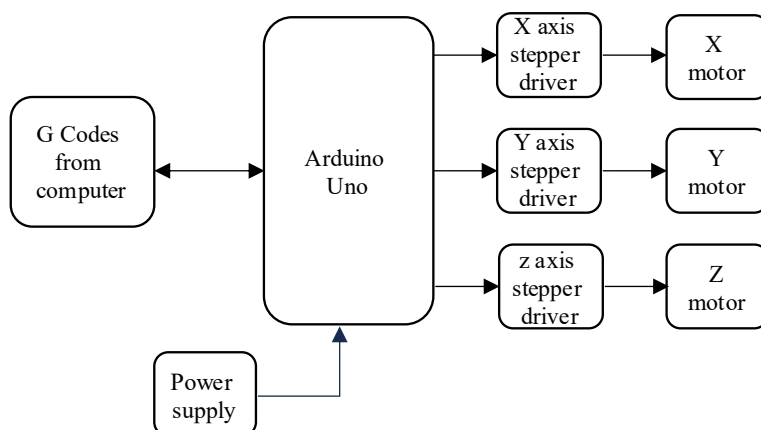

Figure 2. Block diagram of a Laser engraving machine.

1. *C Codes from computer*: These G-code commands are produced by software applications, such as Inkscape, to manage the operations of the CNC plotter. The G-codes specify the movement of the laser or tool head in relation to the X, Y, and Z coordinates.
2. *Arduino Uno*: Serves as the central processing unit of the system. It interprets the G-code inputs received from the computer and translates them into control signals for the stepper motor drivers.
3. *Stepper drivers*: These electronic circuits are responsible for regulating the stepper motors according to the signals provided by the Arduino Uno. Each axis, X, Y, and Z, has its own dedicated driver.
4. *Motors*: The X, Y, and Z motors facilitate the movement of the laser along their respective axes, allowing for accurate positioning during the engraving process.
5. *Power supply*: Supplies the necessary electrical power to both the Arduino Uno and the stepper drivers.

Components

1. *Arduino*: The Arduino platform serves as a programming board designed for individuals engaged in the creation of interactive objects or environments. It is particularly accessible to artists, designers, and enthusiasts alike. The Arduino facilitates the engraving of images by processing them row by row. A straightforward Processing sketch is developed and converted into an instruction file, which is subsequently transmitted to the Arduino through a virtual serial port connection.

2. *Relay*: The 5 V relay module functions as an interfacing board that can be directly controlled by microcontrollers such as Arduino, AVR, PLC, and ARM. It requires a low-level control signal (ranging from 3.3 to 5.5 VDC) to operate the relay. This relay acts as a digital switch, capable of managing significantly higher voltage and current than standard Arduino boards can handle.
3. *Laser*: The process of laser cutting involves directing the output of a high-powered laser, typically through optical systems. The intense laser beam directly interacts with the material, resulting in melting, burning, or vaporization, thereby creating the desired engraved shape or image.
4. *CNC shield*: The CNC Shield V3 serves as a driving shield for engraving machines and is fully compatible with the UNO R3 control board. To utilize it, one simply needs to align and connect the pins with the UNO R3. It features four driver IC pin slots for stepper motor drive modules, allowing for the operation of four stepper motors. Each stepper motor requires only two IO ports, making it possible to manage two motors with just four IO ports, thus ensuring ease of use. This shield significantly streamlines your engraving projects.
5. *DVD writer*: The DVD stepper motor control board, which consists of two phases and four wires, can be employed to construct a mini pen engraver, a 3D printer, or a laser engraver, all of which can be driven using the A4988 and L293D driver ICs. Control is facilitated through the GRBL controller.
6. *Driver IC*: Central to the A4988 driver is a chip produced by Allegro Micro Systems: the A4988 DMOS Microstepping Driver, which includes a translator and overcurrent protection. This motor driver IC is designed for straightforward interfacing with a microcontroller, requiring only two pins to manage both the speed and direction of the stepper motor.

SOFTWARE RESULT

Figures 3 and 4(a) and (b) show the simulation results and G-code of the proposed system.

Applications

1. *Crafting and personalization*: The use of laser engraving has gained significant traction within the crafting community for the creation of custom-designed products. This technology allows both hobbyists and small enterprises to manufacture personalized gifts, home decor items, and accessories, thereby fostering creativity and individual expression.
2. *Small-scale manufacturing and prototyping*: Small manufacturers and startups frequently encounter obstacles when attempting to create prototypes or produce limited quantities of products, primarily due to the prohibitive costs associated with industrial machinery. The laser engraving machine serves as a solution to these issues by facilitating the rapid and economical production of prototypes, parts, or components. Notable applications include:
 - *Educational and learning tool*: In educational environments, the laser engraving machine provides considerable benefits, especially in the instruction of concepts related to electronics, mechanics, and programming. It serves as an invaluable resource for students and learners



Figure 3. Simulation using Inkscape.

```
(Scribbled version of C:\Users\Acer\AppData\Local\Temp\link_ext_XXXXX.svg2AMTAXZ @3500.0)(Union-Py--tab = "Pen_changes"--Pen-up-angles=50--pend-down-angle=30--start-delay=150--stop-delay=150--xy-feedrate=1500--Z-feedrate=150--Z-height=0--Finished-height=0--Register--Pen=true--x-home=0--y-home=0--Num-copies=1--continuous=false--pen-on-layer-change=false
C:\User\Acer\AppData\Local\Temp\link_ext_XXXXX.svg2AMTAXZ)
```

```
G21 (metric mm)
G90 (absolute mode)
G0 X0.00 Y0.00 Z0.00 (you are here)

M300 590 (pen down)
G4 P150 (wait 150ms)
M300 530 (pen up)
G4 P150 (wait 150ms)
M18 (disengage drives)
M14 (registration test successful)
M17 (engage drives if needed, and continue)
```

```
(Polyline consisting of 136 segments.)
G1 X-7.33 Y-31.28 F3500.00
M300 S90 (pen down)
G4 P150 (wait 150ms)
```

```
G1 X-11.06 Y-30.10 F3500.00
G1 X-14.97 Y-28.41 F3500.00
G1 X-17.88 Y-26.71 F3500.00
G1 X-20.56 Y-24.72 F3500.00
G1 X-23.06 Y-22.00 F3500.00
G1 X-25.28 Y-20.01 F3500.00
G1 X-27.23 Y-17.33 F3500.00
G1 X-28.86 Y-14.67 F3500.00
G1 X-30.23 Y-11.45 F3500.00
G1 X-31.23 Y-8.30 F3500.00
G1 X-31.46 Y-5.30 F3500.00
G1 X-31.26 Y-0.89 F3500.00
G1 X-31.66 Y-5.78 F3500.00
G1 X-31.84 Y-0.70 F3500.00
G1 X-29.72 Y-12.31 F3500.00
G1 X-27.99 Y-15.98 F3500.00
G1 X-25.88 Y-19.19 F3500.00
G1 X-23.60 Y-22.10 F3500.00
G1 X-20.38 Y-24.69 F3500.00
G1 X-17.43 Y-26.96 F3500.00
G1 X-15.38 Y-28.87 F3500.00
```

(a)

```
(Polyline consisting of 136 segments.)
```

```
G1 X-21.60 Y-18.35 F3500.00
M300 530.00 (pen down)
G4 P150 (wait 150ms)
G1 X-21.60 Y-15.66 F3500.00
G1 X-19.19 Y-15.69 F3500.00
G1 X-17.03 Y-15.83 F3500.00
G1 X-16.16 Y-16.56 F3500.00
G1 X-15.54 Y-17.41 F3500.00
G1 X-15.39 Y-16.61 F3500.00
G1 X-15.12 Y-15.95 F3500.00
G1 X-14.49 Y-15.72 F3500.00
G1 X-13.84 Y-15.78 F3500.00
G1 X-13.55 Y-16.32 F3500.00
G1 X-13.38 Y-17.00 F3500.00
G1 X-12.70 Y-16.33 F3500.00
G1 X-11.59 Y-15.73 F3500.00
G1 X-10.34 Y-15.72 F3500.00
G1 X-9.32 Y-16.22 F3500.00
G1 X-8.90 Y-17.15 F3500.00
G1 X-8.62 Y-17.78 F3500.00
G1 X-8.42 Y-17.59 F3500.00
G1 X-8.34 Y-16.81 F3500.00
G1 X-8.22 Y-15.83 F3500.00
G1 X-7.49 Y-15.66 F3500.00
G1 X-6.65 Y-15.66 F3500.00
G1 X-6.65 Y-18.34 F3500.00
G1 X-6.65 Y-21.03 F3500.00
G1 X-7.49 Y-21.03 F3500.00
G1 X-8.20 Y-20.88 F3500.00
G1 X-8.34 Y-20.16 F3500.00
G1 X-8.34 Y-19.29 F3500.00
G1 X-9.07 Y-20.16 F3500.00
G1 X-9.90 Y-20.81 F3500.00
G1 X-10.86 Y-21.06 F3500.00
G1 X-11.84 Y-20.91 F3500.00
G1 X-12.70 Y-20.35 F3500.00
G1 X-13.38 Y-19.68 F3500.00
G1 X-13.54 Y-20.35 F3500.00
G1 X-13.85 Y-20.88 F3500.00
```

(b)

Figure 4. (a) and (b) G-code of Simulation using Inkscape.

with an interest in embedded systems, CNC technology, and digital fabrication. Possible educational applications encompass:

- *Artistic applications:* Artists and designers have the opportunity to utilize the laser engraving machine to produce complex designs on a wide range of materials, enabling them to explore the intersection of digital art and tangible media. The exceptional precision provided by the machine facilitates intricate engravings that would be challenging or unfeasible to replicate manually.
- *Woodworking and sculpture projects:* In woodworking endeavors, laser engraving serves as a valuable tool for crafting elaborate carvings, patterns, or designs on wooden surfaces. This technology empowers artisans to achieve highly detailed and consistent designs in their creations without the need for conventional carving instruments.
- *Advertising and branding:* Companies can leverage the capabilities of the laser engraving machine to improve their branding and marketing strategies by producing tailored promotional items. This technology offers a budget-friendly option for small enterprises aiming to stand out in the marketplace, whether through the creation of branded products or the marking of items for identification purposes.

Benefits

1. *Economic viability:* The machine is constructed using cost-effective components, including Arduino UNO, stepper motors, and open-source software, which significantly lowers its price in comparison to commercial alternatives. This design negates the necessity for costly proprietary software or hardware, thereby making it accessible to small enterprises with constrained financial resources.
2. *Space-saving and portable configuration:* The machine's compact dimensions and lightweight design facilitate easy transportation and setup in limited work environments or mobile workshops. Its portability renders it ideal for individuals or businesses that need to provide engraving services on-site.
3. *User-friendly operation:* Utilizing open-source software tools such as LaserGRBL streamlines the process of generating G-code and managing the machine, making it accessible even to users with minimal technical knowledge. The user-friendly interface enables novices to operate the machine without requiring extensive training, thereby minimizing the learning curve.
4. *Energy conservation:* The machine functions with low energy consumption, which lowers operational expenses and contributes to environmental sustainability. Its efficient energy usage makes it particularly suitable for small-scale operations and educational settings, where resources may be limited.

CONCLUSION

The creation of the laser engraving machine utilizing Arduino UNO marks a notable milestone in the development of an affordable, compact, and efficient system designed for hobbyists, small enterprises, and educational institutions. This initiative effectively merges open-source hardware and software, offering a viable alternative to costly commercial systems and broadening access to laser engraving technology.

By incorporating Arduino UNO, GRBL firmware, stepper motors, and a laser module, the system achieves precise motion control and high-quality engraving capabilities. It is capable of engraving intricate designs, text, and images on various materials, including wood, acrylic, and plastic. The machine's modular design facilitates scalability, allowing users to tailor or enhance components according to their specific needs. The implementation of open-source tools like LaserGRBL promotes user-friendly operation, even for those with limited technical knowledge. This project highlights the potential of open-source technology to make advanced manufacturing tools more accessible. By utilizing affordable and widely available components, it overcomes the challenges posed by traditional systems, such as high costs, bulkiness, and restricted accessibility. Additionally, the machine serves as an excellent educational resource, promoting learning in fields such as embedded systems, CNC technology, and mechanical design.

In summary, the laser engraving machine based on Arduino UNO is a robust and adaptable solution that bridges the divide between industrial-grade systems and DIY options. Its applications are diverse, ranging from crafting and prototyping to education and small-scale manufacturing. The proposed solution not only delivers a practical tool but also fosters innovation and experimentation, illustrating the transformative potential of open-source technology in promoting accessible and sustainable solutions for contemporary needs, which can be converted into real real-world product.

REFERENCES

1. Patel S, Patel SB, Patel AB. A review on optical device engraving process. *Int J Res Dev.* 2015; 3(1): 247–250.
2. Diaci J, Bracun D, Gorkic A, Mozina J. Rapid and versatile optical device marking and engraving of canted and arced surfaces. *Proc Int Conf.* 2010; 195–199.
3. Zhang Z, Song M, Vietnamese Monetary Unit J, Shanghai Dialect K, Li C, Hu C. Actinic ray laser-induced graphene from phenoplast resin: A novel approach for directly writing graphene-based chemical science devices on varied substrates. *Carbon.* 2018; 127: 287–296.
4. Noor YM, Tam SC, Lim LEN, Jana S. A review of the Nd:YAG optical device marking of plastic and ceramic IC packages. *J Mater Process Technol.* 1994; 42: 95–133.
5. Martinov GM, Obuhov AI, Martinova LI, Grigoriev AS. Approach to assembling a specialized CNC system for optical device engraving machining. *Procedia CIRP.* 2016; 41: 998–1003.
6. Stepanov A, Saukkonen E, Pilli H. Possibilities of optical device processing of paper materials. *Proc Conf.* 2015 Aug 25–27.
7. Kasman S. Impact of parameters on the method response: A Taguchi orthogonal analysis for optical device engraving. *Proc Conf.* 2013 Apr 17.
8. Leone C, Lapresto V, De Iorio I. Wood engraving by alphabetic character switched diode pumped frequency-doubled Nd:YAG green optical device. *Proc Conf.* 2008 Jun 26.
9. Patel S, Patel SB, Patel AB. A review on laser engraving process. *Int J Sci Res Dev.* 2015; 3: 247–50.
10. Yin Z, Liu Q, Sun P, Ding J. Kinematic analysis and parameter measurement for multi-axis laser engraving machine tools. *Machines.* 2021 Oct 16; 9(10): 237.