

Multidirectional Autonomous UV Sanitation Robot

Lokesh Maddiboyina^{1*}, A.D. Gnanaswara Rao¹, Ayush Sharm¹

Abstract

In the healthcare environment, the spread of infectious diseases through respiratory particles poses a significant challenge to maintaining clean and safe surroundings. With shortages in surface disinfectants, the traditional manual cleaning methods have been put under scrutiny, as they often prove inadequate and leave residual contamination. Moreover, the constant operation of healthcare facilities, coupled with staff turnover, increases the risk of virus transmission among healthcare workers. To address these concerns, a novel solution has been proposed: the development of a disinfecting robot utilizing ultraviolet (UV) rays for efficient microbial reduction. The robot is equipped with obstacle avoidance capabilities, eliminating the need for constant monitoring, and providing a substantial advantage over human-controlled methods. This abstract highlights the importance of innovative technology in maintaining a clean healthcare environment and protecting the well-being of both patients and healthcare workers.

Keywords: UV C light, Bio organism, DNA, Robot, Sensor

INTRODUCTION

An infected person who is suffering from cold, cough, etc., so the tiny respiratory particles from the infected person are spread into the air finally onto the surrounding surfaces. Shortages in surface disinfectants, although worrying. The sole aspect that matters is providing clean environments in healthcare. It challenged the traditional way of cleaning and disinfecting the surrounding surfaces. Despite best practice recommendations, manual cleaning in each hospital is predicated on local protocols, training, understanding, renewal, and staff turnover of cleaning staff because of the control and, therefore, the inspection of their performance. The evidence further suggests that manual cleaning and disinfection is often inadequate and ends in residual contamination. As the healthcare workers and staff must work 24/7 in such places, there is a high chance of getting infected with a virus. Hence, we have come up with the idea of developing a disinfecting robot using ultraviolet rays that can move in multiple directions [1–3]. UV disinfection systems can efficiently reduce microbial contamination. This robot has the ability of obstacle avoidance, so there is no necessity for monitoring, also this feature gives the best advantage over non-contact humans.

*Author for Correspondence

Lokesh Maddiboyina
E-mail: lokesh.maddiboyina2020@vitstudent.ac.in

¹Student, Department of Mechanical Engineering, VIT, Vellore Campus, Katpadi, Vellore, Tamil Nadu, India

Received Date: August 20, 2023

Accepted Date: September 01, 2023

Published Date: September 12, 2023

Citation: Lokesh Maddiboyina, A.D. Gnanaswara Rao, Ayush Sharm. Multidirectional Autonomous UV Sanitation Robot. International Journal of Mechanical Dynamics and Systems Analysis. 2023; 1(1): 1–10p.

METHODOLOGY

It is well known that bio-organisms such as bacteria, spores, and viruses become inactive when subjected to UV-C light irradiation. UV light has been demonstrated to break down the RNA in viruses and may lessen the spread of germs, which may live for extended periods of time on surfaces. The genetic material in pathogens—DNA in bacteria and fungus, RNA in viruses—is destroyed by UV, which prevents them from procreating. The

UV-the robot's first job will be to employ ultraviolet germicidal irradiation to disinfect rooms at various enterprises and organizations, excluding any other industry or location besides the medical one.

LITERATURE REVIEW

- For nearly 50 years, researchers have been studying how UV light kills microorganisms. As soon the new virus started to spread, UV made a comeback as a potentially potent weapon to combat this new affliction.
- With the use of UV light, touchpoints can be cleaned. More recently, UV- C has been utilized to disinfect hospital rooms, and it has been proven to have the ability to lower the number of infectious bacteria that are linked to disease in the vicinity of patients.
- These UV sterilization methods can be applied to robots. The suggested concept is for a robot that uses UV-C lights to clean surfaces.
- The effectiveness of sterilizations can be increased by employing UV LEDs rather than UV radiation lamps like low-pressure mercury lamps [4, 5].

RESEARCH GAP

All UV sanitizing robots that have been produced are huge and can either operate autonomously or with the aid of an app, according to numerous research.

- Reduced size the robot was designed to fit through a variety of small openings.
- The robot doesn't always need human aid, which is why a Bluetooth module isn't there. However, a better microprocessor would enable structured movement made possible by a machine learning model.
- As this is our prototype, it lacks a mapped path. Using a physical button, you may turn the bot on or off.
- The employment of artificial intelligence models to comprehend and map out a floor is a significant area of research that must be addressed.
- We were unable to use the most optimal components in the bot due to procurement issues [6].

COMPONENTS

Ultrasonic Sensors (HCSR04)

Devices that produce or detect ultrasound radiation are called ultrasonic sensors. Transceivers, receivers for communication, and transmitters are the three broad categories into which they can be separated. Transceivers can both transmit and receive ultrasound, whereas broadcasters transform electrical signals into ultrasound and receivers' electrical signals onto ultrasound. The HCSR04 is an economic sensor that provides noncontact measurements from 2cm up to 400cm.

Arduino Uno (At mega 328p)

A freely available electronic platform called Arduino is built on simple hardware and software. A motor can be started, an LED can be turned on, and something may be published online by using an Arduino board to receive inputs like light on a sensor, a user pressing a button, or a tweet. Sending a set of instructions to the board's microchip can tell the board what to do. To do this, the Processing-based Arduino Software (IDE) and the Arduino Programming Language (based on Wiring) are employed. Arduino Uno was used instead of an Arduino Nano due to the thermal capabilities of the former. The Arduino Uno has better thermal capabilities and can power both DC motors [7].

Jumper wires

To connect two places without soldering, jumper wires are simple wires with connector pins at either end. With breadboards and other prototype tools, jumper wires are frequently used to make it simple to change a circuit as required. Jumper wires came in three different varieties:

1. Male-Male
2. Female-Female
3. Male-Female

Motor Driver (L293D)

You can jointly control the working speed and direction of two motors using the electric motor operator module. Because the motor and microcontroller operate at various current rates, it serves as a communication link between them. This motor driver has an operational voltage of 4.5V to 36V with a peak output of 1.2A per channel. We can use the motor driver for different types of motors including DC motors and servo motors. This driver was chosen as it is very compatible and is readily available [8].

DC Motors (Operating voltage 3-12 V, RPM = 150)

A DC motor is a class of rotary electrical motors that converts direct current (DC) electrical energy into mechanical energy. DC motor is being employed as it has an operating voltage within the operating range of the motor driver and a sufficient RPM of 150 which can move the boat in both directions [9].

UV LEDs

These are the sources of disinfection for the bot. They emit UV-C light when current is passed through them and thereby sterilizing the target area.

SOFTWARE USED

Fusion 360

Fusion 360 serves as our primary CAD software where we can design and assemble the various components of our project.

Ultimaker Cura

It is a slicing application primarily used to generate NC code which will be given to 3D printers.

Open-Source Arduino IDE

This will help us control the robot and allow us to program functions into it using a programming language of our choice, in our case python.

Tinker CAD

This is free open-source software available online which is used to design circuits.

V-REP

This results in a small-footprint 3D robot computer that simultaneously mimics authority, actuation, detection, and observing, as shown by the Virtual Robot Experimentation Platform (V-REP).

CAD Model

- The robot is designed to move in and out of congested places while at the same time disinfecting them.
- Two holes have been provided at the front of the bot to accommodate the Ultrasonic sensor which is a key component for obstacle avoidance in our robot.
- UV LEDs will be placed in the four holes present at the bottom of the robot which help in the disinfection process (Figure 1,2,3,4).

V-REP

In this simulation, we created a virtual environment for the robot to test its functioning. V-REP software was used to do the above task. The robot model was imported and then programmed to run in the virtual environment [10]. The robot is programmed to displace from one point to another while avoiding simulated obstacles. The robot successfully executes while maneuvering the environment (Figure 5,6).

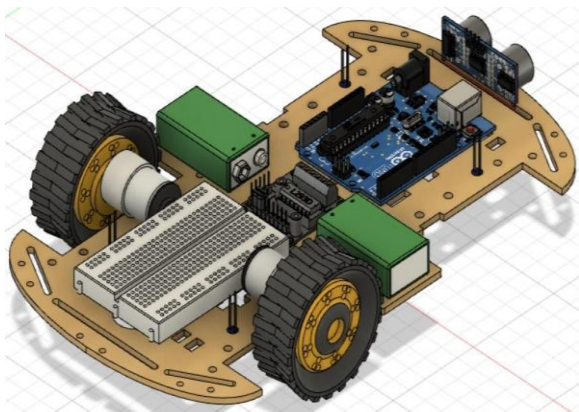

Figure 1. Analysis for the UV Disinfection Robot.

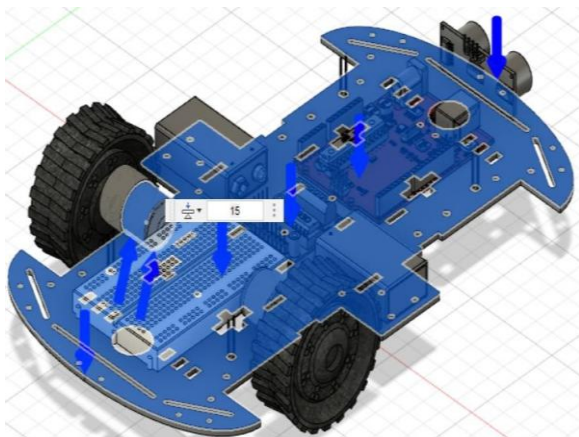

Figure 2. Structural Load of 15 N is the breaking point of the robot.

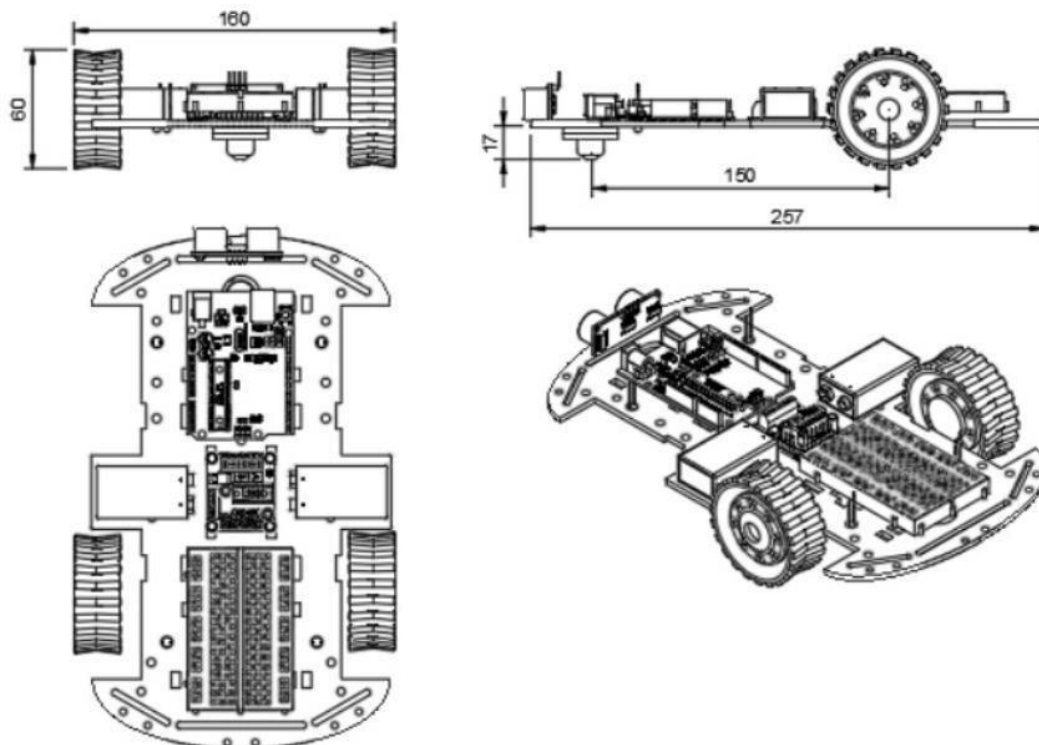
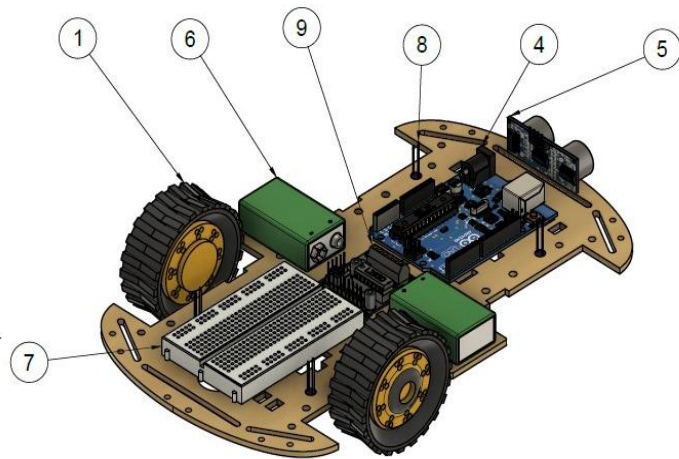

Figure 3. Drafting Design.



Parts List			
Item	Qty	Part Number	Mass
1	2	Wheels v1	284.245 g
2	1	Ball caster wheel v1	28.898 g
3	2	Dc motor v2	0.00 g
4	1	Aurdino v5	58.634 g
5	1	HC-SR04-UltrasonicSensor v7	38.606 g
6	2	9V Battery 01a v5	148.555 g
7	1	Small_breadboard v1	34.278 g
8	4	THT LED blue glass	0.572 g
9	1	L293d motor controller module half H-bridge onsha	32.17 g

Dept.	Technical reference	Created by Lokesh Maddiboyina	Approved by
		Document type	Document status
20BME0700		File Mechatronics Project Assembly	DWG No. Build Of Material
20BME0675			
20BME0695			
	Rev.	Date of issue	Sheet 1/1

Figure 4. Build of Material for the CAD Model.

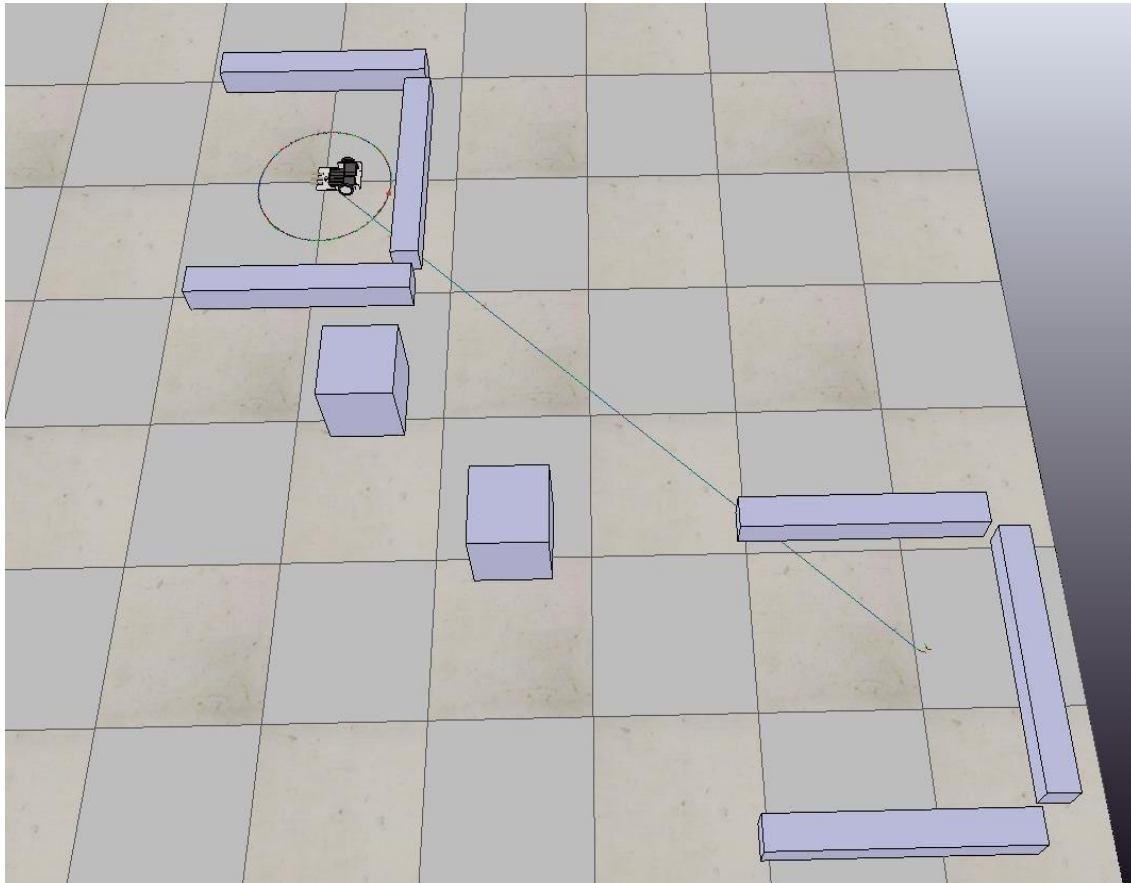

Figure 5. V-REP software.

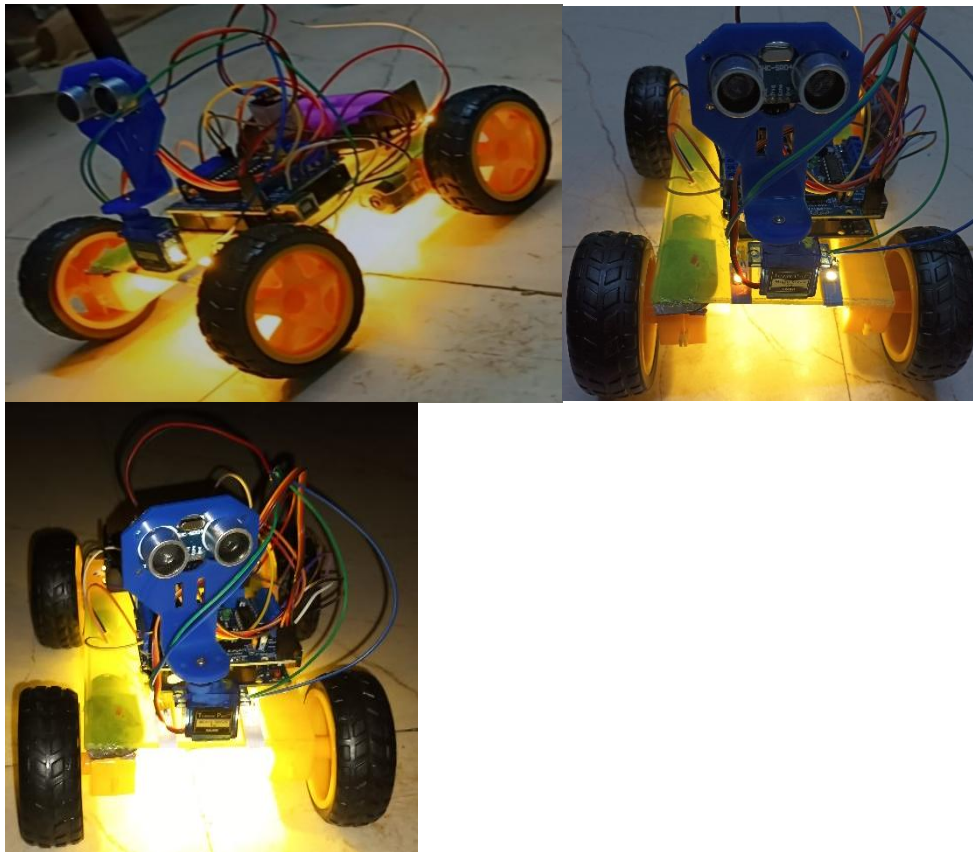

Figure 6. Prototype Model

TINKERCAD

The circuit diagram was constructed in TINKERCAD, and a simulation was run (Figure 7). The code was executed, and the motors ran as per the given instructions (Figure 8).

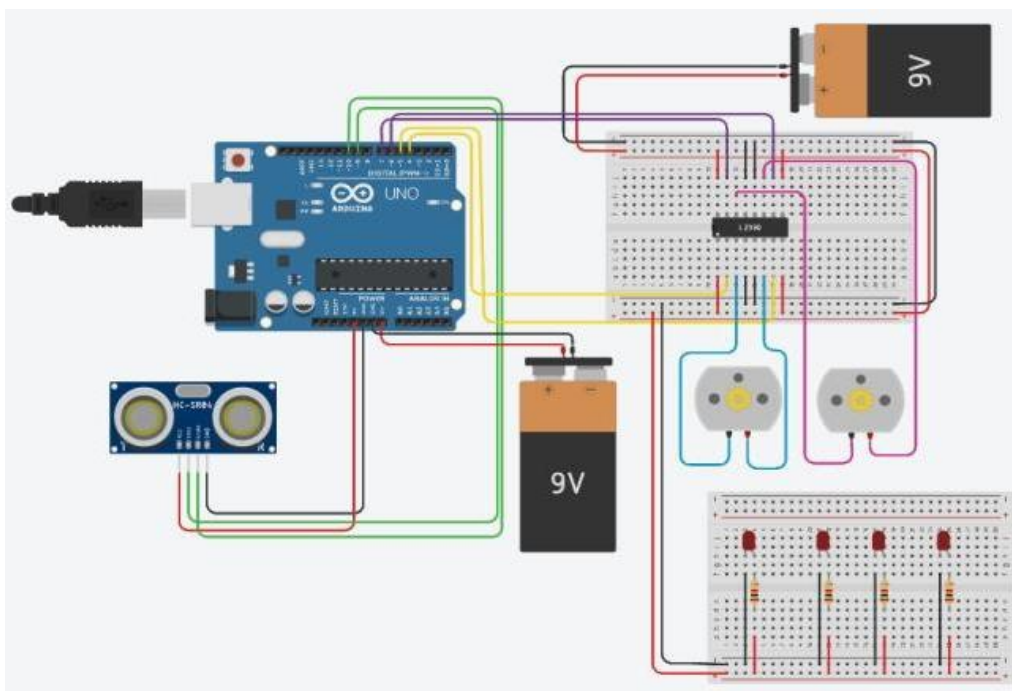

Figure 7. Tinker cad arduino circuit diagram.

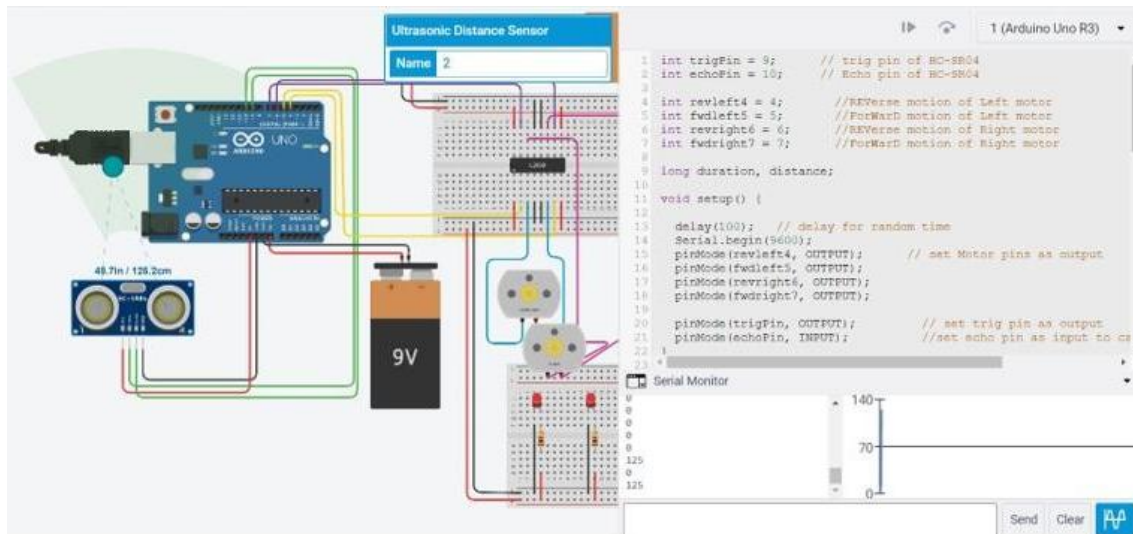

Figure 8. TINKERCAD Code Model.

Program Code

```
//AFMotor Library https://learn.adafruit.com/adafruit-motor-shield/library-install //
//NewPing Library https://github.com/livetronic/Arduino-NewPing//
//Servo Library https://github.com/arduino-libraries/Servo.git //
// To Install the libraries go to sketch >> Include Library >> Add .ZIP File
>> Select the Downloaded ZIP files From the Above links // #include <AFMotor.h>
```

```
#include <NewPing.h> #include <Servo.h>
#define TRIG_PIN A4 #define ECHO_PIN A5
#define MAX_DISTANCE 150
#define MAX_SPEED 150 // sets speed of DC motors #define MAX_SPEED_OFFSET 20
NewPing sonar(TRIG_PIN, ECHO_PIN, MAX_DISTANCE);
```

```
AF_DCMotor motor1(1, MOTOR12_1KHZ); AF_DCMotor motor2(2, MOTOR12_1KHZ);
AF_DCMotor motor3(3, MOTOR34_1KHZ); AF_DCMotor motor4(4, MOTOR34_1KHZ); Servo
myservo;
```

```
boolean goesForward=false;int distance = 100;
int speedSet = 0;
```

```
void setup() {
```

```
myservo.attach(10); myservo.write(115); delay(2000);
distance = readPing(); delay(100);
distance = readPing(); delay(100);
distance = readPing(); delay(100);
distance = readPing();
delay(100);
}
```

```
void loop() {
```

```
int distanceR = 0; int distanceL = 0; delay(40);

if(distance<=20)
{
moveStop(); delay(100); moveBackward(); delay(300); moveStop(); delay(200);
distanceR = lookRight(); delay(200);
distanceL = lookLeft(); delay(200);

if(distanceR>=distanceL)
{

turnRight(); moveStop();
}else
{

turnLeft(); moveStop();} else
{
moveForward();
}
distance = readPing();
}

int lookRight()
{
myservo.write(50); delay(500);
int distance = readPing(); delay(100); myservo.write(115); return distance;
}

int lookLeft()
{

myservo.write(170); delay(500);
int distance = readPing(); delay(100); myservo.write(115); return distance; delay(100);

int readPing() { delay(70);
int cm = sonar.ping_cm(); if(cm==0)
{
cm = 250;
}
return cm;
}

void moveStop() { motor1.run(RELEASE); motor2.run(RELEASE); motor3.run(RELEASE);
motor4.run(RELEASE);
}

void moveForward() {
```

```
if(!goesForward)
{

goesForward=true;          motor1.run(BACKWARD);          motor2.run(BACKWARD);
motor3.run(BACKWARD); motor4.run(BACKWARD);
for (speedSet = 0; speedSet < MAX_SPEED; speedSet +=2) // slowlybring the speed up to avoid
loading down the batteries too quickly
{
motor1.setSpeed(speedSet);          motor2.setSpeed(speedSet);          motor3.setSpeed(speedSet);
motor4.setSpeed(speedSet); delay(5);
}
}

void moveBackward() { goesForward=false; motor1.run(FORWARD); motor2.run(FORWARD);
motor3.run(FORWARD); motor4.run(FORWARD);
for (speedSet = 0; speedSet < MAX_SPEED; speedSet +=2) // slowlybring the speed up to avoid
loading down the batteries too quickly
{
motor1.setSpeed(speedSet);          motor2.setSpeed(speedSet);          motor3.setSpeed(speedSet);
motor4.setSpeed(speedSet); delay(5);
}
}

void turnRight() {

motor1.run(FORWARD);          motor2.run(BACKWARD);          motor3.run(BACKWARD);
motor4.run(FORWARD); delay(2000); motor1.run(BACKWARD); motor2.run(BACKWARD);
motor3.run(BACKWARD); motor4.run(BACKWARD);
}

void turnLeft() { motor1.run(BACKWARD); motor2.run(FORWARD); motor3.run(FORWARD);
motor4.run(BACKWARD); delay(2000); motor1.run(BACKWARD); motor2.run(BACKWARD);
motor3.run(BACKWARD); motor4.run(BACKWARD);
}
```

CONCLUSION

The goal of this project is to design and build a robot that can disinfect surfaces using UV lights and reach congested areas that are difficult to access by humans. Another significant goal of the research is to make the robot self-contained, requiring minimal human involvement. The concept designs were created following the concept. Fusion 360 is used to design the CAD for the elements. The G-codes created by Ultimaker Cura is used to print these designs on 3D printers. We used the open- source Arduino IDE to control the robot. With the help of Tinker-CAD, the circuits were designed. The V-REP Program was used to demonstrate the simulation.

Acknowledgement

We are incredibly humbled and thankful for everyone who has helped us elevate these concepts above the level of simplicity and turn them into something tangible.

We would like to express our sincere gratitude to our teacher Prof. Senthil Kumar S for providing us with this chance, which also enabled us to conduct extensive study and learn about a wide range of novel concepts.

Additionally, we would like to show our gratitude to VIT University, which has helped us throughout our studies and inspired our interest in mechatronics system design.

REFERENCES

1. Anderson M. The ultraviolet offense: germicidal UV lamps destroy vicious viruses. New tech might put them many more places without harming humans. *IEEE Spectr.* 2020;57(10):50-55. doi:10.1109/MSPEC.2020.9205549.
2. Moore G, Ali S, Green EAC, Bradley CR, Wilkinson MAC, Hartley JC, Fraise AP, Wilson APR. Use of UV-C radiation to disinfect non-critical patient care items: a laboratory assessment of the Nanoclave Cabinet. *BMC Infect Dis.* 2012;12(1):1-9:174. doi:10.1186/1471-2334-12-174.
3. Mohammed MN, Hazairin NA, Arif AS, Zubaidi SA, Alkawaz MH, Sairah AK, Jazlan AIIM, Yusuf E. 2019 Novel coronavirus disease (Covid-19): toward a novel design for disinfection robot to combat coronavirus (Covid-19) using IoT based technology. 2021 IEEE 12th Control Syst Grad Res Colloq (ICSGRC). Shah Alam, Malaysia. 2021, Aug 07-07. IEEE. 211-216. doi:10.1109/ICSGRC53186.2021.9515257.
4. Yagi N, Mori M, Hamamoto A, Nakano M, Akutagawa M, Tachibana S, Takahashi A, Ikehara T, Kinouchi Y. Sterilization using 365 nm UV-LED. 2007 29th Annu Int Conf IEEE Eng Med Biol Soc. Lyon, France. 2007, Aug 22-26. IEEE. 5841-5844. doi:10.1109/IEMBS.2007.4353676.
5. Chanprakon P, Oung TS, Treebupachatsakul T, Anan PH, Piyawattanametha W. An ultra-violet sterilization robot for disinfection. 2019 5th Int Conf Eng Appl Sci Technol (ICEAST). Luang Prabang, Laos. 2019, July 02-05. IEEE. 1-4. doi:10.1109/ICEAST.2019.8802528.
6. Tiseni L, Chiaradia D, Gabardi M, Solazzi M, Leonardis D, Frisoli A. UV-C mobile robots with optimized path planning: algorithm design and on-field measurements to improve surface disinfection against SARS-CoV-2. *IEEE Robot Autom Mag.* 2021;28(1):59-70. doi:10.1109/MRA.2020.3045069.
7. Perminov S, Mikhailovskiy N, Sedunin A, Okunevich I, Kalinov I, Kurenkov M, Tsetserukou D. Ultrabot: autonomous mobile robot for indoor UV-C disinfection. 2021 17th Int Conf Autom Sci Eng (CASE). Lyon, France. 2021, Aug 23-27. IEEE. 2147-2152. doi:10.1109/CASE49439.2021.9551413.
8. Peleg M. Microbial dose-response curves and disinfection efficacy models revisited. *Food Eng Rev.* 2021;13(2):305-321. doi:10.1007/s12393-020-09249-6.
9. Yang JH, Wu UI, Tai HM, Sheng WH. Effectiveness of an ultraviolet-C disinfection system for reduction of healthcare-associated pathogens. *J Microbiol Immunol Infect.* 2019;52(3):487-493. doi:10.1016/j.jmii.2017.08.017.
10. Otter JA, Yezli S, Barbut F, Perl TM. 15 - An overview of automated room disinfection systems: When to use them and how to choose them. *Decon Hosp Healthc.* 2nd ed. Delhi, India: Woodhead Publishing Series in Biomaterials; 2020. 323-369. doi:10.1016/B978-0-08-102565-9.00015-7.