

Smart Fast Charging System with Active Cell Balancing for 4S1P Battery Packs and Smart Charger for EVs

Arun R. Nadh^{1*}, Soni S.S.¹, Archa Soman¹, Jaison John²

Abstract

In the realm of electric vehicles (EVs), efficient charging solutions play a pivotal role in enhancing user experience and advancing sustainability. This project introduces three innovative concepts aimed at revolutionizing EV charging infrastructure: Parallel Charging, Smart Charger, and Active Cell Balancing. Parallel Charging introduces a groundbreaking approach to charging by efficiently delivering power to multiple batteries simultaneously. By doing so, it significantly reduces overall charging time, thereby enhancing convenience for EV users seeking expedited charging solutions. The Smart Charger represents a paradigm shift in charging technology, harnessing intelligent charging solutions to optimize the charging process. This innovative system ensures fast and safe charging while seamlessly accommodating various electric vehicle models, eliminating compatibility issues and streamlining the charging experience for users. Active Cell Balancing further enhances battery performance by maintaining uniform charge levels across all cells within the battery pack. This proactive approach not only extends battery lifespan but also maximizes efficiency, contributing to enhanced sustainability and reliability in EV operations. Together, these innovative concepts pave the way for a future where EV charging is not only efficient and convenient but also sustainable and reliable. By embracing these advancements, we can accelerate the adoption of electric vehicles and drive towards a cleaner and greener transportation ecosystem.

Keywords: Smart charger, smart BMS, active cell balancing, parallel charging method, integrated BMS with smart charger

INTRODUCTION

In the rapidly evolving landscape of electric vehicles (EVs), the quest for efficient and sustainable charging solutions has become paramount. As the world shifts towards greener transportation alternatives, the need for innovative charging technologies has never been greater. Addressing this pressing need, our project introduces three groundbreaking concepts poised to revolutionize the EV charging paradigm: Parallel Charging, Smart Charger, and Active Cell Balancing [1].

*Author for Correspondence

Arun R. Nadh
E-mail: arunmadh2002@gmail.com

¹Students, Department of Electrical and Electronics Engineering, Younus College of Engineering & Technology, Pallimukku, Vadakkevila, P.O, Kollam, Kerala, India

²Professor, Department of Electrical and Electronics Engineering, Younus College of Engineering & Technology, Pallimukku, Vadakkevila, P.O., Kollam, Kerala, India

Received Date: May 20, 2024
Accepted Date: May 30, 2024
Published Date: June 08, 2024

Citation: Arun R. Nadh, Soni S.S., Archa Soman, Jaison John. Smart Fast Charging System with Active Cell Balancing for 4S1P Battery Packs and Smart Charger for EVs. Journal of Semiconductor Devices and Circuits. 2024; 11(1): 1–9p.

The advent of Parallel Charging represents a significant leap forward in charging technology. Traditionally, charging multiple batteries required sequential charging, leading to prolonged charging times and inconvenience for EV users. However, with Parallel Charging, we introduce a solution that efficiently delivers power to multiple batteries simultaneously. By leveraging this approach, we aim to drastically reduce overall charging time, thereby enhancing convenience and usability for electric vehicle owners. With the ability to charge multiple batteries in parallel, EV owners can enjoy shorter charging durations, enabling more frequent and seamless use of their vehicles [2].

The Smart Charger represents a pivotal shift towards intelligent charging solutions designed to optimize the charging process. Traditional chargers often lack adaptability and may not be compatible with various electric vehicle models, leading to user frustration and inefficiency. In contrast, our Smart Charger harnesses advanced algorithms and adaptive charging techniques to ensure fast and safe charging while eliminating compatibility issues. By providing a hassle-free charging experience, our Smart Charger empowers EV users with a reliable and efficient charging solution tailored to their specific needs [3].

Furthermore, our project integrates Active Cell Balancing technology to further enhance battery performance and longevity. One of the critical challenges in EV battery management is maintaining uniform charge levels across all cells within the battery pack. Imbalances in charge levels can lead to reduced battery life and compromised performance. Through Active Cell Balancing, we address this challenge by continuously monitoring and adjusting the charge levels of individual cells. By ensuring uniform charge distribution, we extend battery lifespan and maximize efficiency, thereby promoting sustainable and reliable operation of electric vehicles. The block diagram of the same is shown in Figure 1((a) and (b)).

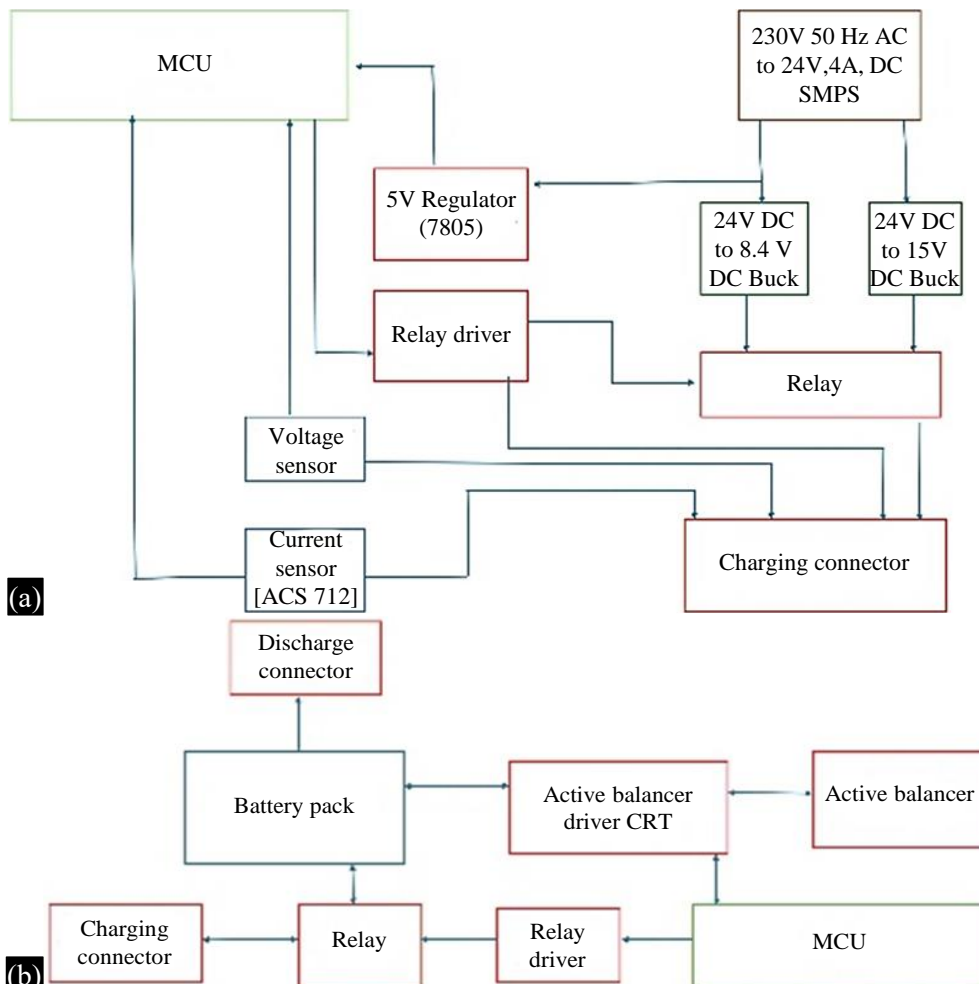

Figure 1. (a) Block Diagram of Smart Charger, (b) Block Diagram of Smart BMS.

As we delve deeper into the intricacies of Parallel Charging, Smart Charger, and Active Cell Balancing, it becomes evident that these concepts represent more than just technological advancements, they embody a commitment to innovation, sustainability, and user-centric design. By pushing the boundaries of EV charging technology, we strive to propel the electric vehicle industry forward,

ushering in a new era of efficient, convenient, and environmentally conscious transportation solutions. Through our project, we aim to empower EV users with cutting-edge charging solutions that not only meet their needs but also contribute to a cleaner and greener future for all [4–7].

PROPOSED OPERATION MECHANISM OF EV FAST CHARGING SYSTEM AND SMART CHARGER

Smart BMS

Our Smart Battery Management System (BMS) represents a significant advancement in the realm of electric vehicle (EV) charging technology. At the core of our system are three relays and a relay driver, working in tandem to optimize the charging process for maximum efficiency and convenience. The proposed mechanism involves dividing the built 16.8 V BMS pack into two separate 8.4 V segments using the relays [8].

Typically, our 4s1p battery pack operates at a charging voltage of 16.8 V as shown in Figure 2. However, our Smart Charging System introduces a transformative approach by converting the battery pack into a 2s2p system during charging. By dividing the pack into two 8.4 V segments, we simplify the charging process, allowing for charging at a lower voltage while still maintaining the overall voltage of the battery backup [9].

This innovative approach offers several advantages, chief among them being the ability to charge the battery pack at a higher current. By dividing the pack into two segments, each segment can be charged independently, effectively doubling the charging current. This enhancement in charging current significantly reduces the overall charging time of the 16.8 V battery pack, thereby enhancing the efficiency and convenience of the charging process.

Moreover, by charging the battery pack at a lower voltage of 8.4 V, we mitigate potential safety risks associated with high-voltage charging. Lower voltage charging not only reduces the risk of overcharging but also helps extend the lifespan of the battery pack by minimizing stress on the individual cells.

Furthermore, our Smart BMS incorporates a relay driver and battery backup system to ensure reliable operation and seamless transition between charging modes. The relay driver controls the operation of the relays, enabling the division of the battery pack into two segments during charging and ensuring proper synchronization of charging cycles.



Figure 2. 16.8 V Battery Pack up.

In summary, our Smart BMS represents a cutting-edge solution that leverages innovative charging techniques to enhance the performance, efficiency, and safety of electric vehicle charging. By intelligently dividing the battery pack into two segments and charging at a lower voltage, we optimize the charging process, reduce charging time, and ensure the longevity of the battery pack. Through our innovative approach, we aim to revolutionize the EV charging experience, making it more convenient, efficient, and environmentally sustainable.

Smart Charger

Our Smart Charger represents a significant advancement in electric vehicle (EV) charging technology, integrating various components and intelligent control mechanisms to optimize the charging process for enhanced efficiency and convenience. At the heart of our Smart Charger is a Switched-Mode Power Supply (SMPS) capable of converting a standard 230 V input to a stable 24 V output with a maximum current capacity of 4 A. This provides the necessary power for charging the EV battery pack efficiently. The circuit diagram of the Smart Charger is shown in Figure 3.

The Smart Charger further incorporates two buck converters, which play a crucial role in regulating the voltage supplied to the battery pack. These buck converters, controlled by a microcontroller unit (MCU), are programmed to identify the specific voltage requirements of the connected EV battery pack. Upon receiving input from the MCU, the buck converters adjust their output voltage accordingly to ensure optimal charging conditions.

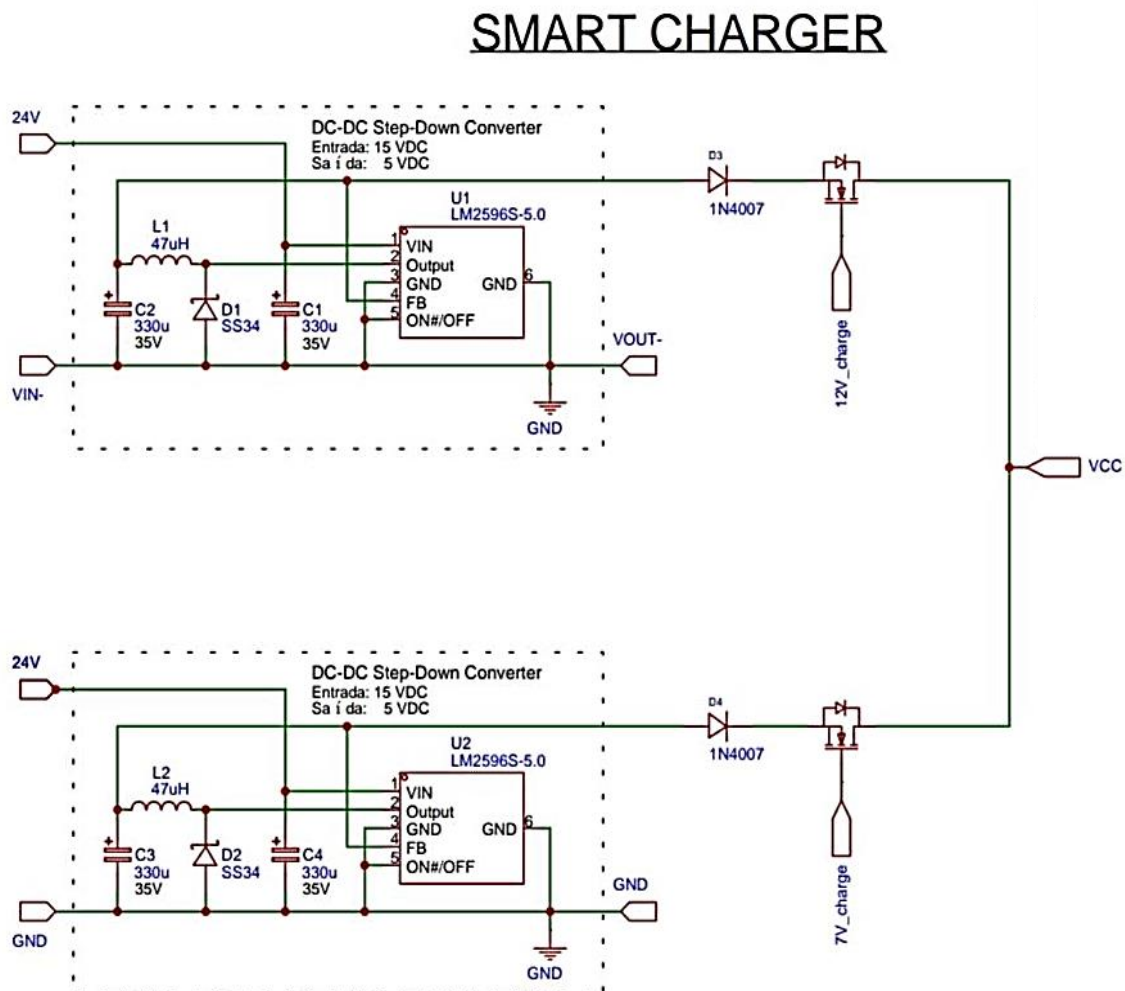

Figure 3. Circuit diagram of smart charger.

In addition to the buck converters, our Smart Charger features two relays, a relay IC, and a regulator IC. These components work in conjunction with the MCU to control the charging process effectively. The relays are used to bypass the feedback pin of the buck converters by MCU, enabling the buck to provide regulated output voltage as per the battery pack's requirements. The regulator IC further assists in maintaining a constant output voltage, ensuring stable charging performance.

To monitor and manage the charging process, our Smart Charger incorporates a current sensor and a voltage sensor. The current sensor detects the current flowing into the battery pack, allowing the MCU to accurately track the charging progress and prevent overloading. Meanwhile, the voltage sensor measures the terminal voltages of the battery pack, providing valuable data for assessing the battery's state of charge (SOC) and overall health [10].

The data collected by the current and voltage sensors are relayed to a graphical user interface (GUI), which serves as the user interface for the Smart Charger. The GUI displays real-time information such as current, voltage, and SOC, enabling users to monitor the charging process conveniently. This intuitive interface enhances user experience and provides valuable insights into the charging status of the EV battery pack.

Overall, our Smart Charger represents a comprehensive solution for EV charging, integrating advanced control algorithms and sensing technologies to deliver fast, safe, and efficient charging performance. By optimizing the charging process and providing real-time monitoring capabilities, our Smart Charger aims to revolutionize the EV charging experience, making it more convenient, reliable, and user-friendly. The diagram of built Smart Charger is shown in Figure 4.

Active Cell Balancing

The Active Cell Balancing system in our project is a critical component designed to enhance the performance and lifespan of electric vehicle (EV) battery packs. Constructed using MOSFETs, capacitors, and relays integrated into a printed circuit board (PCB), this system is engineered to address voltage imbalances among individual cells within the battery pack.



Figure 4. Smart Charger.

To ensure optimal operation, we have employed a unique configuration involving two MOSFETs acting as a single switch. This design choice is crucial for mitigating potential issues such as reverse biasing of the diode inside the MOSFET, which can lead to leakage currents and system failure. By utilizing two MOSFETs in parallel, we effectively prevent such occurrences, thereby enhancing the reliability and performance of the active cell balancing circuitry as shown in Figure 5.

In our implementation, capacitors are chosen over inductors for cell balancing due to their high power factor and capacity. These capacitors are connected in parallel to the individual cells within the battery pack, with each capacitor also being interconnected in parallel to one another. This configuration allows for efficient redistribution of charge among cells, ultimately ensuring uniform voltage levels across the entire battery pack. The circuit diagram is shown in Figure 6.

Bi-directional Switch

The active cell balancing process begins with cells of varying voltages charging the capacitors. Once a capacitor reaches its threshold voltage, the corresponding MOSFET switches off, halting further charging. Subsequently, the charged capacitor transfers its charge to neighboring capacitors with lower potential, gradually equalizing the voltage distribution across all cells.

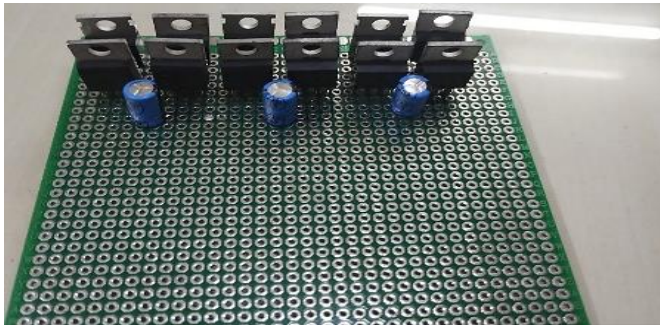

Figure 5. Active cell balancing.

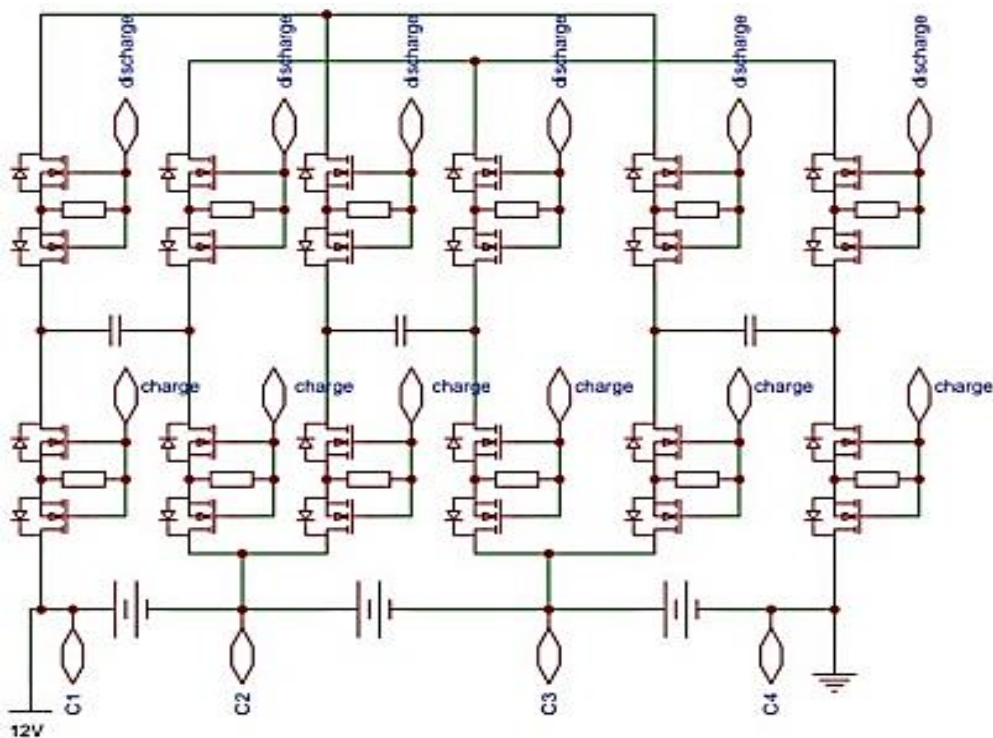

Figure 6. Circuit diagram of Bi-directional switch in active cell balancing.

Throughout this process, a microcontroller plays a pivotal role in regulating the operation of the active cell balancing system. It monitors voltage levels, controls MOSFET switching, and ensures the overall equilibrium of the battery pack. By intelligently managing the charging process, the microcontroller optimizes the performance and longevity of the battery pack, thereby enhancing the overall efficiency and reliability of the EV.

In summary, our Active Cell Balancing system represents a sophisticated solution for addressing voltage imbalances within EV battery packs. Through careful design and integration of components, we have created a robust and efficient system capable of maintaining uniform voltage levels across all cells, ultimately prolonging battery lifespan and enhancing EV performance.

RESULT ANALYSIS

The effectiveness of our Smart Charger system was evaluated through the integration of a TFT display, which provided real-time data on the state of charge (SOC), voltage, and current during the charging process. Additionally, the Arduino IDE was utilized to simulate the charging capabilities of the Smart Charger for different voltages, allowing for comprehensive testing and analysis.

The results demonstrated significant improvements in charging efficiency and time reduction when utilizing the Smart Charger. Charging a 16.8 V battery pack in normal conditions typically required approximately 1 h. However, with the implementation of our Smart Charging System, which converts the battery pack into a 2s2p system during charging, the process was streamlined, resulting in a remarkable reduction in charging time. Specifically, the fast charging method achieved a full charge in just 20 min, as confirmed by both Table 1 and graph representations of the data in Figure 7.

Furthermore, the Active Cell Balancing circuit integrated into our system proved instrumental in enhancing the lifespan of the battery. By maintaining uniform charge levels across all cells within the battery pack, the Active Cell Balancing circuit mitigated issues related to cell imbalance, thereby prolonging the overall longevity and reliability of the battery.

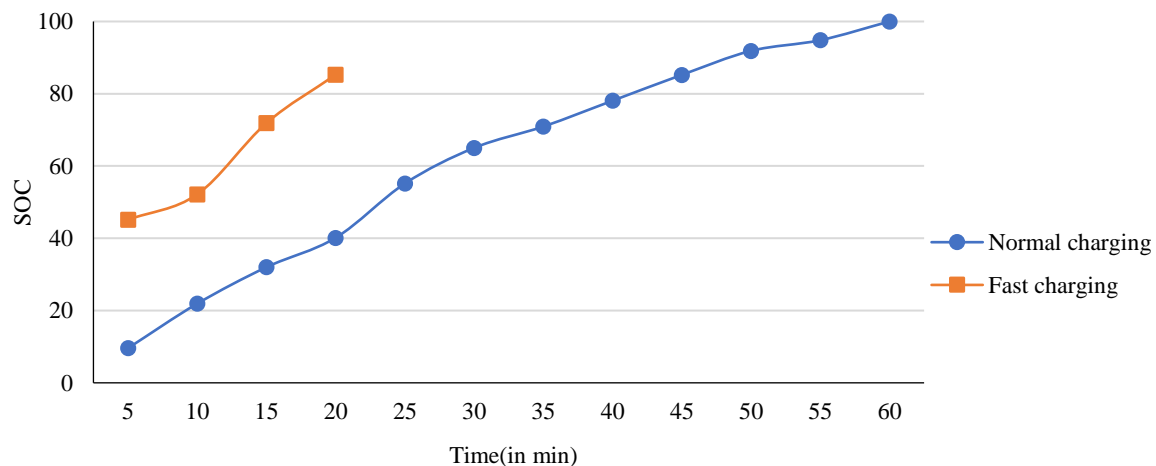

Figure 7. Charging time comparison between normal and fast charging model.

Table 1. Table Showing time for normal and fast charging.

SOC	Normal Charging (min)	Fast Charging (min)
10	5	
40	20	5
60	27	8
80	43	15
100	60	20

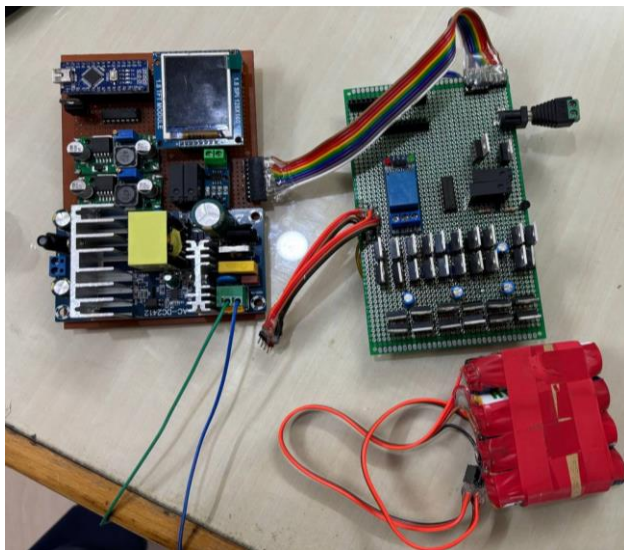

Figure 8. Smart charger integrated with BMS and active cell balancing.

Overall, the results of our analysis underscore the effectiveness and efficiency of our Smart Charger system in optimizing the charging process for electric vehicle batteries. Through real-time monitoring, simulation testing, and data analysis, we have demonstrated the significant benefits of our innovative charging solutions in reducing charging times, extending battery lifespan, and advancing the sustainability of electric transportation technologies. The comprehensive model depicting all aspects of the work done is presented in Figure 8.

CONCLUSION

In conclusion, our project has successfully demonstrated the effectiveness of our innovative charging and battery management solutions for electric vehicles. The implementation of Parallel Charging, Smart Charger, and Active Cell Balancing has proven to significantly enhance the efficiency, convenience, and reliability of EV charging processes. By leveraging advanced technologies such as intelligent charging algorithms, active cell balancing, and microcontroller-based control systems, we have overcome various challenges associated with traditional charging methods, thereby paving the way for a more sustainable and user-friendly EV ecosystem.

Moving forward, we plan to continue refining and optimizing our charging and battery management systems to further improve their performance and reliability. This includes conducting further research into enhancing the efficiency of Parallel Charging, and exploring new techniques for active cell balancing. Additionally, we aim to collaborate with industry partners and stakeholders to integrate our solutions into mainstream EV charging infrastructure, ultimately contributing to the widespread adoption of electric vehicles and the advancement of sustainable transportation technologies. By continuously innovating and adapting to evolving market needs, we are committed to driving positive change in the electric vehicle industry and promoting a cleaner, greener future for all.

Acknowledgments

I would like to extend my heartfelt gratitude to Jerry and Sarath for their invaluable assistance and unwavering support throughout the duration of this project. Their dedication and expertise have been instrumental in the successful completion of our endeavors.

REFERENCES

1. Kovačević H, Stojanović Ž. Buck converter controlled by Arduino Uno. *2016 39th International Convention on Information and Communication Technology, Electronics and Microelectronics (MIPRO)*. 2016; 1638–1642.

2. Erickson RW, Maksimović D. *Fundamentals of Power Electronics*. 2nd Edn. Europe, Kluwer; 2001.
3. Wan K. *Advanced current-mode control techniques for dc-dc power electronic converters*. PhD Thesis. Missouri, United States: Missouri University of Science & Technology; 2009.
4. Cortes P, Kazmierkowski MP, Kennel RM, Quevedo DE, Rodríguez J. Predictive Control in Power Electronics and Drives. *IEEE Trans Ind Electron*. 2008 Dec; 55(12): 4312–4324.
5. Tian Q, et al. A novel energy balanced variable frequency control for input-series-output-parallel modular EV fast charging stations. *2016 IEEE Energy Conversion Congress and Exposition (ECCE)*, Milwaukee, WI, USA. 2016; 1–6.
6. Yilmaz M, Krein P. Review of battery charger topologies, charging power levels and infrastructure for plug-in electric and hybrid vehicles. *IEEE Trans Power Electron*. 2013 May; 28(5): 2151–2169.
7. Wang P, Zhou L, Zhang Y, Li J, Sumner M. Input-parallel Output series DC-DC Boost Converter with a Wide Input Voltage Range, for Fuel Cell Vehicles. *IEEE Trans Veh Technol*. 2017 Sep; 66(9): 7771–7781.
8. Caspar M, et al. Systematic Comparison of Active Balancing: A Model-Based Quantitative Analysis. *IEEE Trans Veh Technol*. 2018 Feb; 67(2): 920–934.
9. Rituparna Paul, Sreejith S (National Institute of Technology). Electric Vehicle Cell Balancing using Single and Multi tiered Switched Capacitor. *2022 IEEE 4th International Conference on Energy, Power and Environment (ICEPE)*, Shillong, India. 2022 Mar; 1–6.
10. Ye Y, et al. Topology, Modelling, and Design of Switched-Capacitor-Based Cell Balancing Systems and Their Balancing Exploration. *IEEE Trans Power Electron*. 2017 Jun; 32(6): 4444–4454.