

IoT-Based Automated Crop Protection System for Smart Farming

Sarthak Rajendra Landge¹, Chaitanya Arun Patil¹, Dhanashree Ajay Vispute¹, Naveen Kumar^{2,*}

Abstract

The development of current technological advancements produces expanded capabilities for agricultural farming production alongside pest management techniques. The Automatic Crop Protection System requires an Arduino controller and Blynk IoT application for monitoring and managing essential environmental parameters including temperature along with humidity as well as soil moisture and pest behavior. Real-time environmental and soil data obtained by the suggested system's sensor array gets analyzed and controlled by an Arduino controller. The system performs automatic actions according to detected information through its database execution process which includes activating pest control measures during pest spot detection and starting irrigation cycles after reaching preset soil dryness levels. Livestock farmers can access Blynk IoT application to both remotely observe their field conditions and receive fast notifications whenever irregularities occur. Successful automation ensures perfect pesticide and water use while needing minimum labor intervention while maintaining green farming quality through reduced environmental waste. The system which was developed to be affordable and scalable matches the needs of farmers operating small to medium-sized farms to protect their crops while optimizing resource management and production levels. The system demonstrates how innovative technology integration between automation and IoT enables better sustainable farming operations from traditional agricultural methods. Furthermore, the proposed system enhances decision-making efficiency by providing continuous data visualization and historical records for performance evaluation. Its modular design allows future integration of advanced sensors and machine learning algorithms, enabling predictive pest management, improved crop health monitoring, and long-term agricultural sustainability.

Keywords: Agriculture technology, arduino, automated irrigation, blynk app, crop monitoring, IoT, pest control, precision agriculture, smart farming, sustainable farming

INTRODUCTION

The primary income source for the main population segment in developing nations springs from agriculture while serving as an essential supportive element for economic development. This sector provides multifold important resources which include energy and fiber in addition to food. The evolving climate presents a significant danger to agricultural harvests together with food resources which increases the sensitivity of farming operations in these regions to climate changes [1–3]. The rise in temperature in warm regions already has the power to decrease farming production and create potential food supply shortages. This problem becomes dire for developing countries that experience unstable climate patterns that reduce agricultural production significantly.

*Author for Correspondence

Naveen Kumar
E-mail: kumarnaveenmkcoe@sanjivani.org.in

¹Student, Department of Mechatronics Engineering, Sanjivani College of Engineering, Kopergaon, Ahmednagar, Maharashtra, India

²Assistant Professor, Department of Mechatronics Engineering, Sanjivani College of Engineering, Kopergaon, Ahmednagar, Maharashtra, India

Received Date: January 29, 2026
Accepted Date: February 02, 2026
Published Date: May 04, 2026

Citation: Sarthak Rajendra Landge, Chaitanya Arun Patil, Dhanashree Ajay Vispute, Naveen Kumar. IoT-Based Automated Crop Protection System for Smart Farming. Research & Reviews Journal of Crop Science and Technology. 2026; 15(2): 1–8p.

Agricultural organizations face two challenges since they contribute to climate change while being

extremely sensitive to its consequences. Agricultural practices produce substantial amounts of greenhouse gas emissions although alternative environmentally compatible solutions exist for emission reduction. The environment together with human health endure detrimental effects from conventional farming methods especially methods depending on excessive synthetic pesticide and fertilizer usage. Many low-income countries face dangerous situations by depending on chemical inputs because this practice endangers their natural ecosystems and farm workers. Farmers become financially exposed because crop losses entirely block their ability to repay loan debts taken for purchasing agrochemicals [4–6].

Farmers resort to pesticide use based on their financial standing, predicted output amounts and market conditions and their academic background. Climate change affects these variables indirectly through modified rainfall and temperature patterns thus the control measures for pests may increase. Pesticide prices demonstrate an ambiguous increase in their values yet the specific price changes remain uncertain. Colder conditions require longer generation times and disease spread for pests to thrive which makes hotter temperatures along with more volatile rainfall patterns likely to worsen pest outbreaks [7–9].

Different species appear to react differently to climatic variations. A specific population could develop successfully in presentable environmental scenarios but another one might not adapt well. The response of pests to climate change depends on how various local environmental factors influence both temperature thresholds and humidity levels between pests and climate elements which requires separate evaluation of pest dynamics across different areas.

LITERATURE REVIEW

Agriculture stands out as one of the sectors where the Internet of Things (IoT) has directly led to substantial innovation among numerous industrial applications. The core concept of IoT consists in linking physical objects to the internet for data collection and distribution followed by evaluation. Through IoT technology farmers achieve better resource management while increasing their yield outputs and pests and disease prevention through enhanced accuracy [10–12].

Fast decision-making becomes possible through IoT systems because they include real-time environmental monitoring devices and sensors which collect important data. System controls identify important soil water conditions alongside outside temperature readings and environmental conditions which support crop defense. Access to real-time data enables farmers to detect developing crop stress indicators which enables them to make appropriate actions To prevent potential losses [13–15].

The exact delivery capability which allows farmers to administer irrigation and fertilization and pesticides through IoT systems results in sustainable agricultural practices. The high level of precision reduces environmental harm and resource waste, therefore, enabling improved farming methods. IoT provides farmers the capability to limit chemical and water use amounts to enhance environmental outcomes and improve production efficiency [16–18].

The sector benefits significantly from IoT data generation abilities. Machine learning algorithms combined with complex algorithms apply predictive value to these datasets for disease outbreak tests and pest invasions forecasts. Knowledge of early risks at hand assists farmers to initiate protective measures which diminish the need for reactive responses while enhancing plan execution [19, 20].

The use of data-driven choices helps farmers to make precise input selections which improves their production outputs. The smart methodology achieves both resource conservation and production increase while ensuring sustainability.

Widespread implementation of IoT in agriculture faces relevant barriers which need resolution. The primary impediment especially affecting small farmers is the steep financial requirement for purchasing

sensors and connectivity devices and necessary infrastructure. The systems require dependable internet connectivity for proper operation since many rural farming areas still lack adequate network access. The essential need exists to protect IoT data from harm. Security concerns about ownership control and data privacy and misuse occur because IoT systems aggregate extensive personal agricultural information that external providers typically store. The successful implementation of digital technologies requires established laws and safety procedures for data security because they protect farmer interests and ensure technology responsibility [5].

MAJOR COMPONENTS USED

Arduino UNO

As the base element of the Arduino UNO development board the ATmega328P microcontroller provides its foundation [21, 22]. The device works well for multiple electronic projects through its digital combined with analog I/O functionalities. The electronic board connects expansion modules as well as peripheral devices through its combination of six analog inputs and fourteen digital I/O pins. The board works at an operating range between 7 to 20 volts and functions using either a 9V battery or USB power source. The main programming tool for Arduino devices is the Integrated Development Environment (IDE) while the Arduino Nano and UNO share most functional characteristics. The device works as an essential solution for embedded applications that need sensor and communication module interfacing because of its ability to adapt.

LCD Display (16×2)

Electronic project applications benefit from the liquid crystal display (LCD) as a primary visual output device because this component uses low power while maintaining transparency. The 16×2 LCD stands as one of the favorite options among all the available types. Each character occupies a 5×7 pixel grid in the display and fills up to 16 characters per row on its two rows. The LCD module operates through sequential access of two main registers called the command register and the data register. The command register handles the three functions of cursor placement control together with content clearing and display initialization. People recognize the 16×2 LCD as a module that easily accepts programming tasks and functions to show custom characters. Embedded systems use LCD 16×2 as their preferred display option over standard components, such as seven-segment displays and LED modules because of its flexible programming interface and readable output.

Relay Module

Relays operate as electromechanical components which control electrical current circulation based on low-power control signals. The device implements switch functionality based on control source data to manage electrical contacts in either open or closed positions. Inside a standard relay functions an iron yoke to direct magnetic fields as the device contains a soft iron core integrated with a coil. A hinged armature attached to the yoke starts moving because of the magnetic field that develops when current runs through the coil. The spring-operated armature maintains a connection to switching contacts. Relays hold great importance in automation because they allow low-power signals to activate high-power circuits.

Soil Moisture Sensor

A soil moisture sensor has the function of evaluating the water content in the soil. The procedure for determining soil electrical resistance uses two conductive probes as standard components. The two probes develop higher resistance when the ground is dry yet exhibit lower resistance as the soil moisture level rises. The measurement of soil resistance changes allows the determination of water content in the soil. The sensors supply irrigation automation systems with accurate watering schedules. The sensors ensure proper water delivery to plants through their function of promoting water conservation and crop health improvement.

DHT11 Temperature and Humidity Sensor

DHT11 functions as a preferred digital instrument to monitor temperature together with relative humidity levels. The quantity of moisture existing in the atmosphere forms a concept known as humidity

which significantly influences diverse physical and chemical and biological operations. Industrial facilities need correct humidity control to create secure facilities while protecting product standards. Automated climate control systems together with agricultural monitoring applications find the DHT11 to be their sensible choice because it delivers dependable readings of temperature and humidity. The measurement approach determines two main categories for humidity sensors between absolute and relative types.

ESP8266 Wi-Fi Module

The ESP8266 stands out as a preferred affordable wireless sensor network and Internet of Things project Wi-Fi module because of its small size. Many projects avoid using ESP8266 Wi-Fi module because its power consumption level goes against battery-operated functionality though it performs well in connecting systems. The Arduino Pro Mini functions as a recommended 3.3V microcontroller choice for this application. The safe supply of power between 5V boards and Arduino UNO requires using a voltage regulator, such as AMS1117. During data transmission the stable operation of equipment depends on large capacitors which prevent rapid voltage declination. Firmware updating on the module needs to happen before use because stable operation relies on precise serial communication setup.

METHODOLOGY

Basic crop defense during different seasons drives the main reason for agricultural IoT technology integration. The implementation of IoT-based systems represents a successful application among numerous advanced farming methods to control and monitor greenhouse environments. A system that automates vital control parameters including temperature along with humidity and irrigation was built through the study of present greenhouse technology implementations.

The project relies on wireless communication networks to transfer live data communication. A wireless sensor network including crop-monitoring sensor types and environmental sensors gets installed throughout the greenhouse for information collection. After receiving the data the farmer obtains the capability to initiate immediate corrective actions. The technology enables farmers to optimize farm practices through continuous field updates from wherever they are located or wherever they choose to be. Figure 1 displays a block diagram. A picture of the real-world implemented system can be found in Figure 2.

A smart agricultural monitoring system has been developed through Internet of Things technology and multiple sensor implementation to protect crops better. The system contains a thermistor which detects irregular temperature fluctuations that might indicate fire formation and initiates an audio warning response. A proper assessment of irrigation water availability relies on sensors which measure

Block diagram

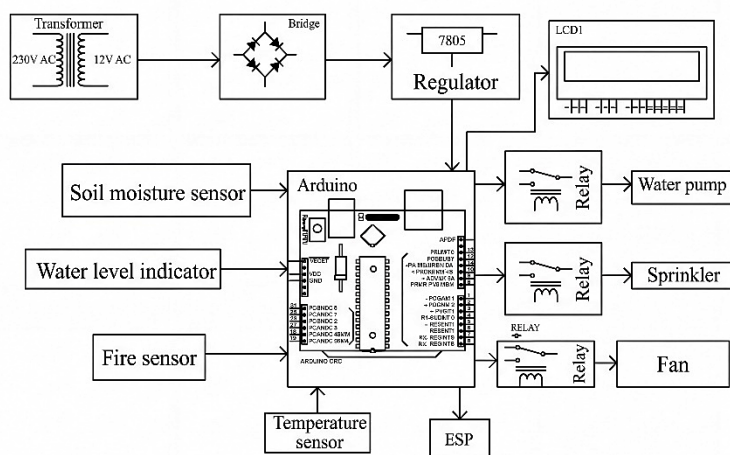

Figure 1. Block diagram of automated crop protection system.

soil water content and water reservoir levels. The DHT11 temperature and humidity sensor operates in the surrounding environment to keep track of essential conditions which support crop health and productive growth. Figure 3 displays the circuit diagram.

The UNO Arduino microcontroller handles sensor data acquisition while running a program comparison against established threshold values contained in the system. The Arduino system alerts the ESP8266 Wi-Fi module to notify users when sensor values exceed their set thresholds. The system transfers current data to the Blynk mobile application that the farmer uses through their smartphone for immediate notification and necessary response.

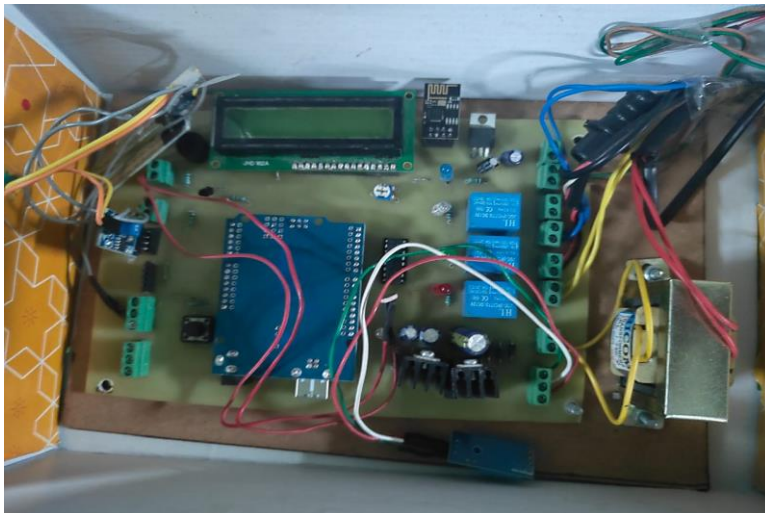

Figure 2. Image of actual implemented model.

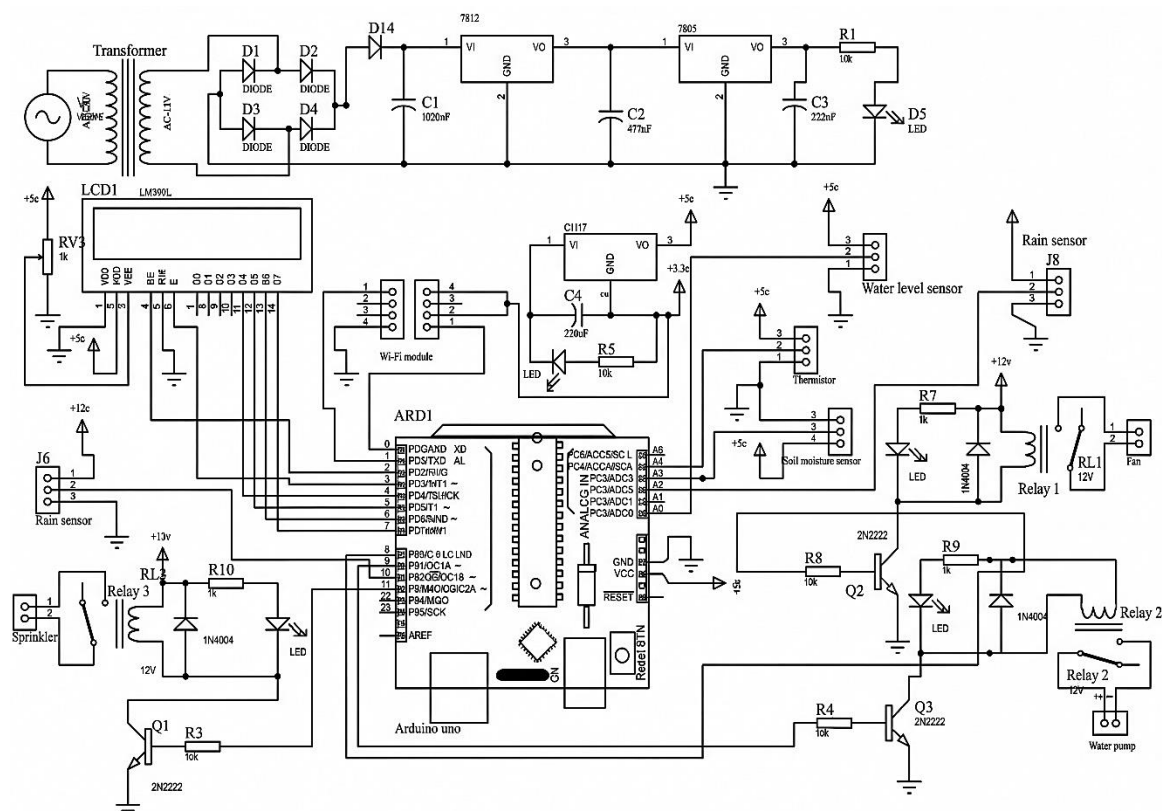
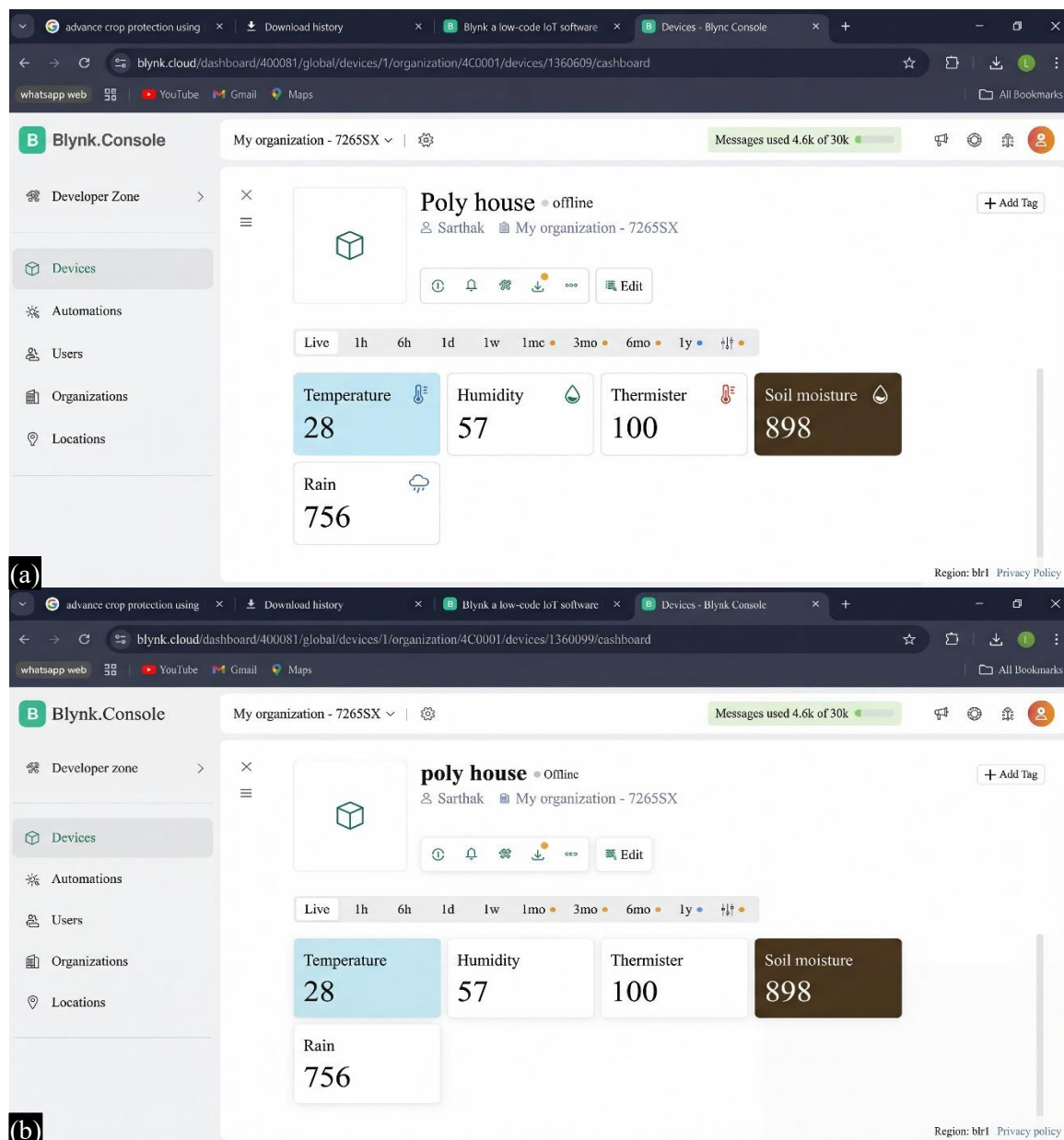

Figure 3. Circuit diagram of automated crop protection system.

The developed system delivers reliable performance at affordable costs while enabling farmers to make knowledgeable decisions through continuous observation using this device.

RESULTS

A system for agricultural monitoring delivered real-time surveillance capabilities because of the Blynk platform and the IoT-based agricultural system design. Through this system farmers gained access to environmental monitoring data directly on their smartphone dashboards. Through remote control capabilities of the system farmers could operate irrigation pumps without direct human involvement. The system produced automatic warning messages when sensor measurements reached pre-defined marks like low soil wetness that required swift corrective actions. Through Blynk users gained access to data log features and visualization tools which presented historical patterns to enable them to make knowledgeable agricultural decisions. The Arduino UNO and inexpensive components integrated smoothly for set-up because of which the system became cost-effective. Users who lacked technical experience could easily manage the agricultural setup through the Blynk platform using a user-friendly interface with drag-and-drop functionality. Results are shown in Figure 4.



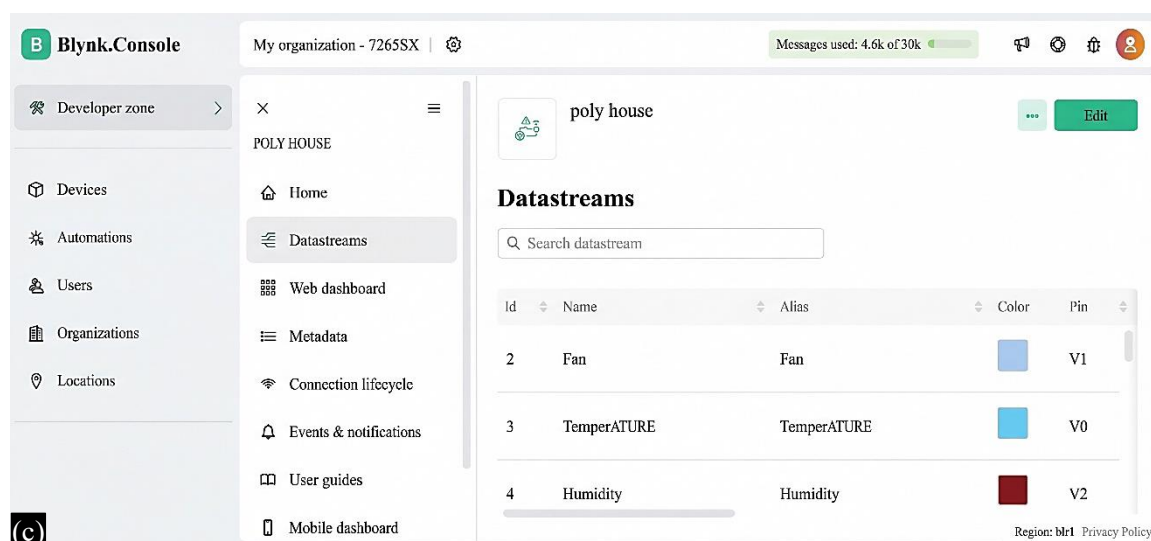

Figure 4. Results of testing.

CONCLUSION

The project holds major social value since it deals directly with essential problems the agriculture industry is currently facing. The smart system was designed to deliver cost-efficient sustainable protection combined with integrated monitoring service for farms. The principal aim of this system is to minimize crop damage and shield agricultural zones from unauthorized entry along with wild animals that result in serious crop destruction. The automated environmental monitoring system eliminates time-consuming manual supervision thus conserving farmer effort and time. The system improves both agricultural yields and farming resources security and helps agricultural operations sustain financial stability. The deployment of these technology-based measures enables sustainable modern agriculture that meets future requirements of security and food production sustainability.

REFERENCES

1. Vikaspedia. IoT in agriculture. In: Agriculture Portal, editor. ICT Applications in Agriculture. 1st edition. Hyderabad, India: Vikaspedia; 2024. pp. 1–10.
2. Bhosale SS, Shinde AS. Internet of things in agriculture: A review. In: Patel R, editor. Smart Farming Technologies. 2nd edition. Mumbai, India: ResearchGate; 2023. pp. 102–115.
3. Aernpeak E. IoT in agriculture: Technology use cases for smart farming and challenges to consider. In: EAernpeak Blog, editor. Digital Agriculture Solutions. 1st edition. Tallinn, Estonia: EAernpeak; 2024. pp. 1–5.
4. Sowmya M, Kumar MSC, Sahana RA, Monisha RH. IoT in agricultural crop protection and power generation. In: Gupta S, editor. Engineering Research and Technology. 12th edition. Bangalore, India: IJERT Publishing; 2023. pp. 120–128.
5. Vaish R, Al-Shaikh SM, Shah SK, Dhabliya D, Devi RV. Automated smart crop protection utilizing IoT: A comprehensive review. In: Sharma P, editor. E3S Web of Conferences. 1st edition. Les Ulis, France: EDP Sciences; 2024. pp. 1–15.
6. Jain S, Gupta R. IoT-based smart farming: A review. In: Kumar V, editor. Engineering and Technology. 9th edition. Delhi, India: ISET; 2020. pp. 23–30.
7. Kumar P, Sharma S. Smart irrigation system using IoT: A case study on water efficiency. In: Reddy L, editor. Agricultural Systems. 1st edition. Mumbai, India: Elsevier; 2021. pp. 47–54.
8. Patel H, Patel M. Development of IoT based precision agriculture system using sensors. In: Singh K, editor. Computer Applications. 1st edition. New York, USA: IJCA Publishing; 2019. pp. 1–5.
9. Ramachandran S, Srinivasan V. Blynk-based IoT applications in agriculture: A review. In: Proc. 2022 Int. Conf. Smart Comput. Commun. Syst., editor. Smart Computing and Communication Systems. 1st edition. Chennai, India: IEEE; 2022. pp. 165–171.

10. Sharma N, Agarwal A. Real-time pest monitoring and control in agriculture using IoT and machine learning. In: Kumar A, editor. *Journal of Agricultural Engineering*. 25th edition. Berlin, Germany: Springer; 2018. pp. 100–109.
11. Zhang H, Li Y. Sustainable agriculture and resource management using internet of things (IoT) in smart farms. In: White J, editor. *Environmental Monitoring and Assessment*. 192nd edition. Cham, Switzerland: Springer; 2020. pp. 1–14.
12. Ali M, Islam S. Internet of things (IoT) and smart farming: The impact of IoT on agriculture. In: IEEE Access, editor. *Advanced IoT Applications*. 9th edition. Piscataway, USA: IEEE; 2021. pp. 45875–45887.
13. Singh G, Thakur M. Automation in agriculture using IoT-based monitoring and control system. In: TJPRC, editor. *International Journal of Agricultural Science and Research*. 9th edition. Chennai, India: TJPRC; 2019. pp. 51–57.
14. Kavitha S, Rajasekaran P. IoT-enabled smart pest control system for sustainable agriculture. In: Watson B, editor. *Sensors and Actuators B: Chemical*. 349th edition. Amsterdam, Netherlands: Elsevier; 2022. pp. 1–12.
15. Suresh P, Vijayakumar P. IoT-based environmental monitoring for agriculture. In: RSC, editor. *Journal of Environmental Monitoring*. 23rd edition. Cambridge, UK: Royal Society of Chemistry; 2021. pp. 567–576.
16. Jayasuriya YP, Elvitigala CS, Warnakulasooriya K, Sudantha BH. Low cost and IoT based greenhouse with climate monitoring and controlling system for tropical countries. In: IEEE Member Conference Paper, editor. *Greenhouse Systems*. 1st edition. Colombo, Sri Lanka: IEEE; 2020. pp. 10–18.
17. Hassanien RHE, Li M, Yin F. The integration of semi-transparent photovoltaics on greenhouse roof for energy and plant production. In: *renewable Energy*, editor. *Sustainable Power*. 121st edition. London, UK: Elsevier; 2018. pp. 377–388.
18. Danita M, Mathew B, Shereen N, Sharon N, Paul JJ. IoT based automated greenhouse monitoring system. In: Proc. 2018 Int. Conf. Intelligent Computing and Control Systems (ICICCS), editor. *Intelligent Computing*. 1st edition. Madurai, India: IEEE; 2018. pp. 45–52.
19. Changqing C, Hui L, Wenjun H. Internet of agriculture-based low cost smart greenhouse remote monitor system. In: Proc. 2018 Chinese Automation Congress (CAC), editor. *Automation Congress Proceedings*. 1st edition. Beijing, China: IEEE; 2018. pp. 88–94.
20. Singh G, Mani DD, Kumar D, Prasad HR. Smart irrigation with field protection and crop health monitoring system using autonomous rover. In: Proc. 2019 5th Int. Conf. Advanced Computing & Communication Systems (ICACCS), editor. *Advanced Computing Systems*. 5th edition. Coimbatore, India: IEEE; 2019. pp. 112–120.
21. Naranje RA, Kale KJ, Chavan PKP, Shirke OA, Wakchaure KN, Kumar N. Doodle bot: An advanced robot to draw complex geometrical shapes. In: Gupta A, editor. *Innovative Practices in Technology and Management*. 4th edition. Noida, India: IEEE Publishing; 2024. pp. 45–50.
22. Naranje RA, Kale KJ, Chavan PP, Kumar V, Kumar N. Development of 5 axis robotic manipulator for material handling and sorting. In: Khan M, editor. *Advances in Transdisciplinary Engineering*. 58th edition. Amsterdam, Netherlands: IOS Press; 2024. pp. 547–553.