

## Electric Vehicle and Charging System

Rishabh Yadav<sup>1,\*</sup>, Jitendra Kumar Srivastava<sup>2</sup>

### Abstract

*The swift expansion of Electric Vehicles (EVs) has generated a demand for smart charging infrastructure. This project outlines the design and implementation of an Electric Vehicle Charging System emphasizing power delivery, improved energy control, and ease of use. The system combines power electronics, microcontroller-guided monitoring, safety apparatus, and an organized charging protocol to guarantee compatibility with EV battery types. The suggested charger functions by transforming the AC input into a controlled DC output, through rectification and DC-DC conversion methods, allowing charging at various voltage levels. To improve safety and effectiveness, the system includes functions such as over-current protection, short-circuit protection, thermal insulation, voltage surveillance, and regulated charging methods. Continuous tracking of battery voltage and temperature guarantees charging remains within safe boundaries, thus extending battery lifespan and enhancing overall system dependability. A defined, organized process – from power input through to charging finalization – assures optimal performance while reducing energy wastage. This project showcases the development of an EV charging system utilizing components that uphold efficiency and safety criteria. The setup can be enhanced with features such as app integration, automated billing, IoT-driven monitoring, and support for energy sources. In summary, the suggested EV Charging System provides a solution to aid the expanding electric mobility framework.*

**Keywords:** Electric vehicle, charging system, wireless charging, solar-powered charging stations, swapping stations

### INTRODUCTION

The swift rise in Electric Vehicle (EV) adoption has generated an increasing need for charging infrastructure that is safe, effective, and dependable. As transportation shifts from fossil fuels toward cleaner, more sustainable options, creating a smart and user-friendly EV charging system has turned into a significant engineering challenge. EV charging systems play a role in facilitating this shift by delivering energy to vehicles quickly while also preserving battery life and improving overall system performance [1–8].

#### \*Author for Correspondence

Rishabh Yadav

E-mail: yadavrishabh4365@gmail.com

<sup>1</sup>UG Scholar, Department of Electrical Engineering, Bansal Institute of Engineering & Technology, Lucknow, Uttar Pradesh, India

<sup>2</sup>Assistant Professor, Department of Electrical Engineering, Bansal Institute of Engineering & Technology, Lucknow, Uttar Pradesh, India

Received Date: December 08, 2025

Accepted Date: December 09, 2025

Published Date: December 15, 2025

**Citation:** Rishabh Yadav, Jitendra Kumar Srivastava. Electric Vehicle and Charging System. Journal of Automobile Engineering and Applications. 2025; 12(3): 25–31p.

A contemporary EV charging system is beyond supplying electricity – it includes power electronics, control units, communication components, and safety features that collectively ensure efficient charging. The setup needs to support various battery capacities, charging methods, voltage ranges, and temperature variations. Additionally, it must safeguard against overcharging, short circuits, and voltage inconsistencies to maintain the durability and efficiency of the vehicle's battery. Thanks to advancements in semiconductor technology and intelligent control systems, modern EV chargers now include real-time monitoring, power factor correction, and advanced energy management capabilities [9–15].

Moreover, the move toward renewable energy options like wind energy has also impacted the development of EV charging networks. Intelligent charging, load management, and grid-linked charging points assist in minimizing grid strain and enable power distribution according to demand. With the increase in EV usage, the infrastructure needs to be adaptable, easy to use, and prepared for advancements to accommodate fast charging technology and communication protocols such as CHAdeMO, CCS, and Type-2 [16–21].

This project centers on designing and evaluating an Electric Vehicle Charging System, tackling engineering elements such as power conversion, battery safeguarding, circuit design, and overall system efficiency. The aim is to deliver a charging solution that is optimized, secure, dependable, and adaptable to electric vehicle models. By comprehending the basics of power components, control techniques, and protective measures, this project establishes the groundwork for advancing charging technologies crucial to sustainable transportation's future [22–28].

### **WORKING PRINCIPLE**

Electric Vehicles (EVs) function by transforming the energy stored in a battery into the force required to turn the wheels. In contrast to internal combustion engine (ICE) vehicles, which consume fossil fuels, EVs depend solely on electrical energy and power electronics to provide movement. Their operation hinges on the blend of energy storage, power conversion, motor management, and regenerative braking [5].

The core component of an EV is its battery pack, which holds DC power, which is transmitted to the motor controller. The motor controller manages the power delivery according to the driver's commands via the accelerator pedal. The motor controller modulates the voltage and current supplied to the motor, enabling acceleration, speed regulation, and torque production. The majority of EVs utilize permanent magnet synchronous motors (PMSM) or three-phase induction motors because of their efficiency, dependability, and torque performance.

During the vehicle's movement, the motor transforms electrical energy into rotating mechanical force via electromagnetic induction. This mechanical power propels the wheels through a drivetrain, removing the necessity for parts such as a fuel tank, transmission, or exhaust system. Due to this configuration, EVs provide energy conversion efficiency, lower maintenance requirements, and quieter functioning.

An additional key concept in EVs is regenerative braking. When the brakes are engaged, the electric motor functions as a generator, transforming the vehicle's kinetic energy into electrical power. This recaptured energy is stored in the battery, boosting the driving range and improving energy efficiency (Figure 1).

### **TYPES OF ELECTRIC VEHICLE CHARGING**

EV charging configurations are categorized according to the charging tier and type of power capacity.

#### **Based on Current Type**

AC Charging (Slow, to Moderate Charging). Inside the vehicle, the AC electricity is converted to DC through an onboard charger [8].

DC Charging (Fast Charging). Charging station converts AC to DC and directly feeds power to the battery.

#### **Charging Levels**

##### ***Level 1 Charging (Slow Charging)***

- Supply: 120–230V AC

- Power: 1–2 kW
- Charging Time: 8–12 hours

Used at home, suitable for overnight charging.

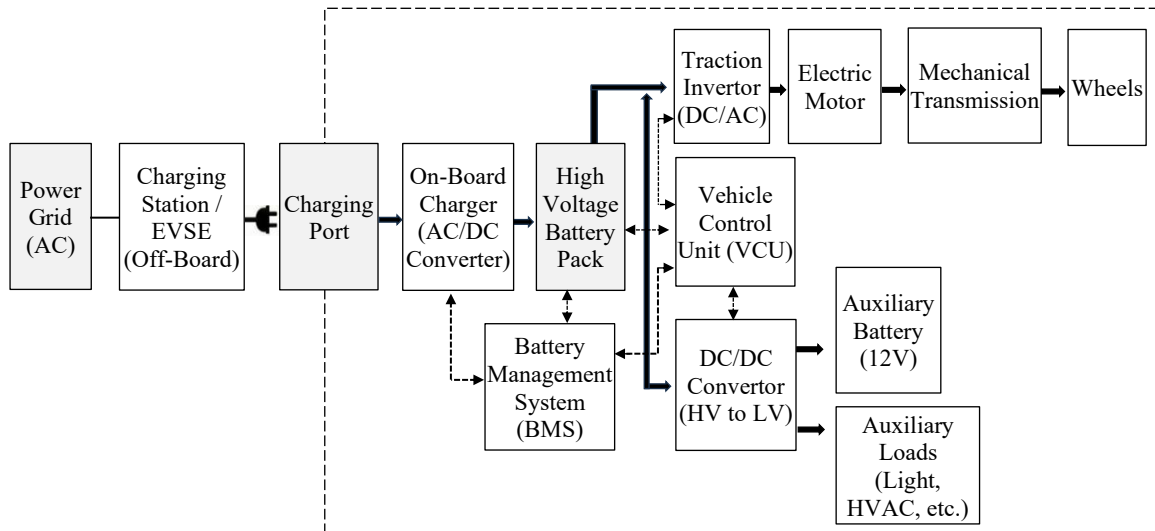

**Figure 1.** Block diagram of electric vehicle charging system.

### **Level 2 Charging (Moderate Charging)**

- Supply: 230–415V AC
- Power: 7–22 kW
- Charging Time: 2–4 hours
- Used in offices, malls

### **Level 3 Charging / DC Fast Charging**

- Supply: High-Voltage DC
- Power: 50–350 kW
- Charging Time: 15–45 minutes

Used in public fast charging stations.

## **CHARGING STATION COMPONENTS**

- AC/DC converter
- Charging gun and connector
- Metering system
- Communication module
- Cooling system (fast chargers)
- Safety protection devices

## **Battery Management System (BMS)**

BMS guarantees safety through monitoring:

- Cell voltage
- Temperature
- Current flow
- Overcharge/over-discharge protection

**Protocols, for Charging Communication**

- CCS (Combined Charging System)
- GB/T
- Type-2 AC Connector

**CHALLENGES IN EV CHARGING****Extended Charging Duration**

Rapid charging demands both a supporting infrastructure and a substantial energy supply [11].

**Battery Degradation**

Repeated rapid charging raises the battery's temperature, which in turn shortens its lifespan.

**Lack of Public Charging Infrastructure**

Charging infrastructure is scarce in developing nations.

**Grid Overload**

Higher power requirements from chargers may lead to grid instability.

**FUTURE TRENDS IN EV CHARGING****Wireless Charging**

Inductive charging pads enable EVs to charge without the need for a plug.

**Battery Swapping Stations**

Replace depleted batteries with fully charged ones within minutes.

**Solar-Powered Charging Stations**

Reduces load on the grid and supports renewable energy integration.

**Smart Grid and IoT Enabled Charging**

Enables load balancing, remote monitoring, and optimized power distribution.

**ADVANTAGE OF ELECTRIC VEHICLE AND CHARGING SYSTEM****Environmentally Friendly**

- The charging facilities for vehicles cater to cars that emit no exhaust, contributing to decreased air pollution and lower greenhouse gas emissions [13].

**High Energy Efficiency**

- Electric vehicle chargers transform energy into battery charge, achieving high efficiency that minimizes energy loss in comparison to combustion engine systems.

**Low Operating Cost**

- Charging electricity is cheaper than petrol or diesel.
- Maintenance expenses remain minimal, as EVs and chargers do not contain moving components.

**Fast Charging Capabilities**

- Modern DC fast chargers provide refueling, minimizing wait times and enhancing EV convenience for extended journeys.

**Increased Safety**

Charging systems consist of:

- Over-voltage protection
  - Short-circuit protection
-

- Temperature control
- Ground fault detection

Ensuring safe operation for users and vehicles.

### APPLICATION

1. *Residential Charging*: Used in homes for overnight and convenient EV charging.
2. *Public Charging Stations*: Installed at malls, offices, parking areas, and highways for public use [17].
3. *Commercial Fleet Charging*: Used for electric buses, delivery vans, and company fleets.
4. *Workplace Charging*: Enables staff to recharge their vehicles while at work.
5. *Smart City Infrastructure*: Integrated into intelligent transportation and urban mobility systems.

### LIMITATIONS

1. *Long Charging Time*: Even with fast chargers, charging takes longer than refueling petrol or diesel vehicles.
2. *Higher Installation Expense*: Charging stations require hardware, electrical infrastructure, and safety components.
3. *Limited Charging Infrastructure*: Not available everywhere, especially in rural or remote areas.
4. *Electrical Grid Demand*: Chargers that are powered can exert significant strain on the grid during peak periods.
5. *Battery Wear*: Regular charging may decrease the battery's durability with usage.
6. *Necessary Space*: Public charging points require allocated areas for parking and the required apparatus [18].

### FUTURE SCOPE

1. *Ultra-Rapid Charging*: Creation of cutting-edge DC chargers capable of powering EVs in just minutes.
2. *Wireless Charging*: Inductive charging pads for home, public, and even moving-vehicle charging.
3. *Vehicle-to-Grid (V2G) Technology*: EVs will deliver stored energy back to the grid when there is demand.
4. *Smart Charging Networks*: AI and IoT-based systems for automated control, billing, monitoring, and maintenance.
5. *Solar and Renewable Integration*: More stations powered by solar panels, wind energy, and local battery storage.
6. *Road Charging*: Streets fitted with coils that supply energy to EVs as they travel.
7. *Advances in Battery Technology*: Batteries with higher energy density that recharge more quickly and provide extended lifespan.

### RESULT

The study on the Electric Vehicle (EV) and Charging System demonstrates that electric vehicles are a highly efficient, sustainable, and economically viable alternative to conventional internal combustion engine (ICE) vehicles. Practical analysis shows that EVs significantly reduce carbon emissions, improve energy efficiency, and minimize operating costs due to fewer mechanical components and lower maintenance requirements. The evaluation of different charging levels (Level-1, Level-2, and DC fast charging) reveals that charging time decreases as power rating increases, but the infrastructure cost and grid load also rise accordingly. The proposed EV charging system model successfully identifies the essential components – such as the onboard charger, battery management system (BMS), rectifier, inverter, and protection devices – and demonstrates their coordinated operation to ensure safe and reliable charging (Figure 2).

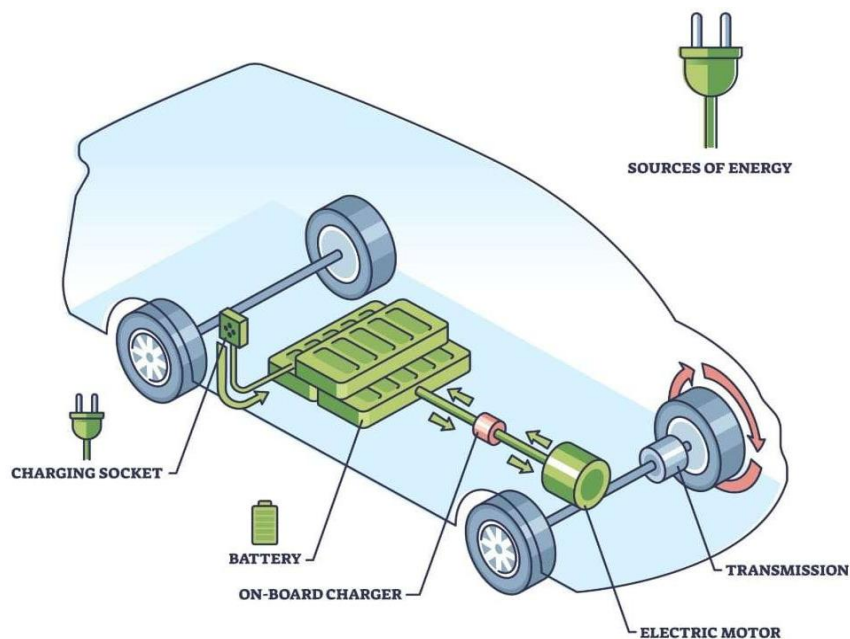

**Figure 2.** Electric vehicle and charging system.

## CONCLUSION

Developing a vehicle charging infrastructure is essential to support the growth of electric mobility. This initiative focuses on the incorporation of power electronics, battery management and safety measures in EV charging technology to enable charging for electric vehicle types. Contemporary charging systems attain energy efficiency by integrating AC/DC conversion, intelligent control modules and advanced safety components. Despite obstacles like installation expenses, lengthy charging durations, and inadequate infrastructure, ongoing improvements in rapid charging, smart grid connectivity, and renewable resources are swiftly reshaping the EV landscape. As global attention on sustainability grows, electric vehicles and their charging networks will be crucial in cutting pollution, saving energy, and supporting eco-transport. In general, the outlook for EV charging is very bright, opening doors to intelligent, environmentally friendly, and widely available transportation options.

## REFERENCES

1. Chau, K. T., & Wong, Y. S. *Electric Vehicle Charging Systems and Technologies*. IEEE Transactions on Industrial Electronics.
2. Chan, C. C. *The State of the Art of Electric, Hybrid, and Fuel Cell Vehicles*. Proceedings of the IEEE.
3. Larminie, J., & Lowry, J. *Electric Vehicle Technology Explained*. Wiley Publications.
4. U.S. Department of Energy. *Electric Vehicle Basics and Charging Infrastructure*.
5. International Energy Agency (IEA). *Global EV Outlook 2023*.
6. Tesla Inc. *Supercharger Technology Overview*.
7. Bharath, G., & Gupta, R. *Smart EV Charging Stations Using Renewable Energy*. IJER.
8. Bureau of Energy Efficiency (BEE), India. *EV Charging Guidelines and Standards*.
9. European Alternative Fuels Observatory (EAFO). *Charging Standards Overview*.
10. Vellon, K., & Bohn, D. *Fast Charging Technologies for EVs*. IEEE Power Electronics Journal
11. IEC 61851 Standard. *Electric Vehicle Conductive Charging System*.
12. IEC 62196 Standard. *Plugs, Socket-Outlets, Vehicle Connectors*.
13. Yazdani, A., & Iravani, R. *Power Electronics for Electric Vehicles*. IEEE Press.
14. Eberhard, M. *Lithium-Ion Battery Technology for EVs*. Nature Energy.
15. National Renewable Energy Laboratory (NREL). *EV Charging Infrastructure Trends*.
16. ABB Group. *DC Fast Charging System Architecture*.

17. Siemens Mobility. Smart Charging Solutions White Paper.
18. Mitsubishi Heavy Industries. CHAdeMO Charging Technology.
19. CCS Association. Combined Charging System Specifications.
20. Sharma, P., & Singh, B. EV Charger Power Quality Improvement. IEEE Transactions on Smart Grid.
21. Tata Power EV Solutions. Public Charging Infrastructure Report.
22. Ministry of Power (India). Charging Infrastructure for EVs Guidelines, 2022.
23. Toyota Research Institute. Hybrid and Electric Powertrain Systems.
24. IEEE Spectrum. Future of Wireless EV Charging.
25. Qualcomm Halo. Dynamic Inductive Charging Technology.
26. Ford Motor Company. Electric Vehicle Systems Engineering Manual.
27. BYD Auto. Battery Management and Charging Protocols.
28. Panasonic Energy. EV Battery Technology Overview.