

## E-rationing System Using Microcontroller, RFID and GSM

Chavan Sunil Shivaji<sup>1, \*</sup>, Kshitij Kailas Walunjkar<sup>1</sup>, Ashutosh Kumar<sup>1</sup>, D.M. Bhalerao<sup>2</sup>

### Abstract

*These papers represent the Literature Survey on E-Rationing Systems reveals the pivotal role of microcontroller, RFID, and GSM integration in modernizing ration distribution. The system employs RFID tags for beneficiary identification, ensuring efficient tracking and authentication during ration distribution. A microcontroller manages data processing and inventory control, while GSM communication enables real-time updates and notifications to authorities and beneficiaries. The proposed system aims to enhance transparency, reduce manual errors, and optimize the efficiency of ration distribution processes to control the distribution of rationed goods, the suggested system connects a central microcontroller unit with GSM modules, RFID readers, and user interfaces. Users receive RFID-tagged ration cards upon registration, which facilitates easy identification and authentication at distribution locations. Instant updates on user entitlements, stock levels, and transaction records are made possible by real-time GSM connectivity with a central server. As people become aware of the need for a paradigm shift, governments, non-governmental organizations, and humanitarian groups are depending more and more on technology-enabled solutions to enhance the effectiveness, accountability, and openness of food distribution systems. Experimental results demonstrate the effectiveness and feasibility of the system in addressing the challenges of modern-day rationing systems.*

**Keywords:** E-Rationing card, electronic governance, Microcontroller, RFID, GSM, Password.

### INTRODUCTION

Technology has become a revolutionary factor in the global search for efficient and fair food delivery, altering existing methods and encouraging innovation. The Electronic Rationing (E-Rationing) system is one of the innovative developments. It is a state-of-the-art method that uses microcontrollers, RFID, and the Global System for Mobile Communication (GSM) to modernize and simplify the distribution of basic food supplies. The concepts, advantages, and uses of electronic rationing systems in tackling global food security issues are examined in this article. The Public Distribution System in India faces

#### \*Author for Correspondence

Chavan Sunil Shivaji  
E-mail: sunilchavan6486@gmail.com

<sup>1</sup>Student, Department of Electronics and Telecommunication Engineering, Sinhgad College of Engineering (affiliated to Savitribai Phule Pune University), Pune, Maharashtra, India

<sup>2</sup>Professor, Department of Electronics and Telecommunication Engineering, Sinhgad College of Engineering (affiliated to Savitribai Phule Pune University), Pune, Maharashtra, India

Received Date: May 05, 2024

Accepted Date: May 23, 2024

Published Date: June 03, 2024

**Citation:** Chavan Sunil Shivaji, Kshitij Kailas Walunjkar, Ashutosh Kumar, D.M. Bhalerao. E-rationing System Using Microcontroller, RFID and GSM. Journal of Electronic Design Technology. 2024; 15(1): 25–30p.

issues of malpractice, such as inaccurate measurements and illegal ration shop use without prior knowledge of ration card holders. A proposed system based on RFID and GSM can help control these malpractices by replacing manual work with an automatic system. Consumers provide an RFID card with unique identification numbers, which is scanned by a microcontroller at the ration shop. Once validated, the system asks the consumer to select the appropriate material and quantity through a keypad. GSM-enabled communication sends information in the form of SMS to related people. This RFID-based automatic ration shop system would increase transparency and prevent malpractices, while also increasing transparency between the public and the government [9]. This would also reduce manual

---

power and automate the dissemination of ration materials. More than ever, the world needs creative solutions to address the intricate relationship between poverty, socioeconomic inequality, and food insecurity. E-rationing programmes are a ray of hope because they provide a way to implement fair, effective, and transparent food distribution networks that respect diversity, inclusivity, and resilience [10].

### **Modernization Is Essential**

It is still extremely difficult to guarantee that everyone has access to food, especially in areas that are afflicted by natural catastrophes, poverty, or violence. Conventional rationing systems are frequently plagued with inefficiencies, errors, and vulnerability to fraud or corruption since they rely on human record-keeping and paper-based paperwork. Misallocation of resources, exclusion of qualified recipients, and food waste are caused by distribution delays, beneficiary identification mistakes, and a lack of real-time monitoring.

Governments, non-governmental organizations, and humanitarian groups are increasingly relying on technology-enabled solutions to improve the efficiency, accountability, and transparency of food distribution systems as they realize the need for a paradigm shift. E-rationing systems are a revolutionary method that makes use of GSM networks, RFID tags, and microcontrollers to transform the distribution, allocation, and monitoring of necessities.

### **LITERATURE SURVEY**

In their 2018 paper, Bhatnagar, Singh, and Singh proposed an E-Ration Card System leveraging RFID and biometric technologies. The system aimed to modernize traditional ration card systems by integrating RFID for card identification and biometric authentication for enhanced security. This approach aimed to streamline the distribution process while ensuring accuracy and reducing the risk of fraud [1].

Verma, Kaur, and Singh proposed an innovative E-Ration Card Management System in their 2019 paper, employing RFID technology. Their system aimed to modernize ration card management by utilizing RFID tags to uniquely identify cardholders, facilitating efficient distribution and monitoring. This approach sought to minimize manual errors and enhance accountability within the ration distribution process, ultimately improving service delivery to beneficiaries [2].

Singh, Sahu, and Katiyar's 2018 paper presents a Smart Ration Card System integrating RFID and GSM technologies. This system enables real-time monitoring of ration distribution through RFID card authentication and GSM communication. By leveraging these technologies, the system enhances transparency, reduces fraud, and ensures efficient allocation of rations, addressing key challenges in traditional ration distribution systems [3].

Shukla and Tiwari's 2019 paper introduces an E-Ration Card Management System incorporating IoT and RFID technologies. By leveraging IoT, the system enables real-time monitoring and management of ration distribution processes, enhancing efficiency and transparency. RFID technology is utilized for secure identification and authentication of ration cardholders, ensuring accurate allocation of rations. This integrated approach improves the overall effectiveness of ration distribution systems, addressing challenges related to manual processes and accountability [4].

In their 2017 paper, Agrawal and Yadav proposed an E-Ration Card System integrating RFID and biometric technology for enhanced efficiency and security. The system utilizes RFID tags for card identification and biometric authentication to verify the identity of ration cardholders. By combining these technologies, the system ensures accurate distribution of rations while minimizing the risk of fraud or misuse, thereby improving the overall effectiveness of ration management [5].

In their 2016 paper presented at the IEEE International Conference on Smart Computing (SMARTCOMP), Amitangshu Pal and Krishna Kant introduce "Smartporter," a novel architecture

designed for efficient transport of perishable food items and people in smart urban areas. This architecture likely integrates IoT, smart sensors, and data analytics to optimize transportation routes, minimize food wastage, and enhance overall urban mobility. The Smartporter system aims to address challenges related to urban logistics and transportation management, contributing to more sustainable and efficient city living [6].

In their paper presented at the 2017 IEEE International Conference on Recent Trends in Electronics, Information & Communication Technology (RTEICT) in Bangalore, R. Padmavathi et al. propose a system for digitalized Aadhar-enabled ration distribution using smart cards. This system likely leverages Aadhar authentication for identity verification and smart cards for efficient and secure distribution of rations, aiming to modernize and streamline the traditional ration distribution process in India. The integration of digital technology enhances transparency and reduces manual errors in ration distribution, ensuring efficient allocation of resources to beneficiaries [7].

In their review published in the International Journal of Computer Sciences and Engineering in 2019, Supriya Lokhande and Sagar Shinde provide an overview of smart ration distribution systems. The paper likely examines various technological approaches, such as IoT, RFID, and biometrics, employed in modernizing ration distribution processes [8].

## EXISTING SYSTEM

The public having a ration card to shop for the substances from the ration shops. While get the fabric from the ratio store, first need to publish the ration card and they may put the signal within the ratio card relies upon at the substances. Then they will difficulty the substances through weighting system with assist of human. There may be chance to promote the fabric to unauthorized character without intimation to owner. On every occasion an unauthorized person attempts to use the ration card then concurrently get alert to unique character through GSM. Based on RFID generation it's far used to offer safety for authorizes character i.e. family members however in this device massive quantity of statistics storage isn't always applicable.

An e-rationing system is primarily composed of three essential parts:

1. *Microcontroller*: The brains of the system, the microcontroller is a programmable platform that may be used to manage data, operate hardware peripherals, and carry out pre-programmed activities. Popular microcontroller options that are well-liked for their adaptability, cost, and simplicity of integration are ESP32, Arduino, and Raspberry Pi.
2. *RFID technology*: Ration cards and beneficiary profiles can be uniquely identified and tracked by RFID tags, which are made up of an antenna and a microchip. Digitally encoded data, including beneficiary specifics, entitlements, and transaction history, is transmitted by RFID tags when they are scanned by RFID readers that are integrated into distribution terminals or portable devices. By doing away with the need for human verification, this smooth and contactless authentication method cuts down on errors and waiting times.
3. *GSM communication*: The E-Rationing equipment and a central server or cloud-based platform can communicate wirelessly thanks to GSM modules. Beneficiaries can get real-time information about their entitlements, distribution schedules, and authentication status by utilizing mobile networks to get alerts, notifications, and updates. Additionally, distribution center administrators may watch inventory levels, keep an eye on distribution activities, and react quickly to new difficulties thanks to the remote monitoring and management capabilities provided by GSM technology.

## PROPOSED SYSTEM

The E-Rationing System leveraging microcontroller, RFID, and GSM technology offers a sophisticated solution for efficient ration distribution. The microcontroller manages user authentication through RFID tags, while GSM enables real-time communication for administrators to monitor and manage distribution remotely via mobile networks. This contemporary system enhances transparency, minimizes fraud, and optimizes resource allocation, addressing the evolving needs of modern rationing systems.

## BLOCK DIAGRAM

All things considered, this technique simplifies the ration distribution procedure, lowers the possibility of fraud or abuse, and gives users an easy way to obtain necessities. It makes use of technology to improve ration distribution's security, accountability, and transparency. The block diagram is shown in Figure 1.

1. The Central Server is responsible for overseeing the fundamental operations of the system, such as the database that houses user data, inventory, ration entitlements, and transaction logs.
2. *ATmega328 Microcontroller*: Manages and synchronizes the diverse hardware elements, extracts information from RFID tags, regulates the DC motor and relay, and establishes communication with the GSM module.
3. *RFID Reader*: During distribution, this device reads the RFID tags on commodities or ration cards to identify the users and the things.
4. *DC Motor*: Manages the system that dispenses goods.
5. *Solenoid valve*: Regulates the movement of goods.
6. *Relay*: Manages the solenoid valve's and other components' power supply.
7. *Buzzer*: it provides audible alerts and notifications.
8. *LEDs*: It indicates the various status of the system.
9. *GSM Module*: Enables real-time updates on user entitlements and transaction data by facilitating communication between the microcontroller and the central server.
10. *User Interface*: consists of a display interface to give feedback on transaction details and a keypad or touchscreen for user interaction, enabling users to input required data such quantities or PIN codes.

## RESULT

The outcome is depicted in Figure 2. The user can interact with the system by using a keypad or touchscreen to enter necessary data, such as quantities or PIN codes, and to get transaction details. It uses technology to increase security, accountability, and transparency of ration distribution.

There are numerous advantages to using E-Rationing systems in a variety of fields:

1. *Efficiency*: E-rationing systems minimize paperwork, optimize resource utilization, and improve distribution workflows by automating processes and decreasing manual interventions. Administrators can find bottlenecks, optimize routes, and raise distribution operations' overall effectiveness with the help of real-time data analytics.
2. *Transparency*: By keeping digital records of beneficiary transactions, distribution activities, and inventory movements, e-rationing systems improve accountability and transparency. By limiting who can alter or access sensitive information, audit trails and access controls help to reduce the possibility of fraud, theft, or poor management.
3. *Inclusivity*: By utilizing GSM technology, E-Rationing systems make it easier to communicate with recipients, even those who are isolated or disadvantaged and have little access to conventional methods of distribution. Beneficiaries can confirm their entitlements, give input on the quality of services, and receive timely notifications through SMS alerts, audio messages, and interactive voice response (IVR) systems.

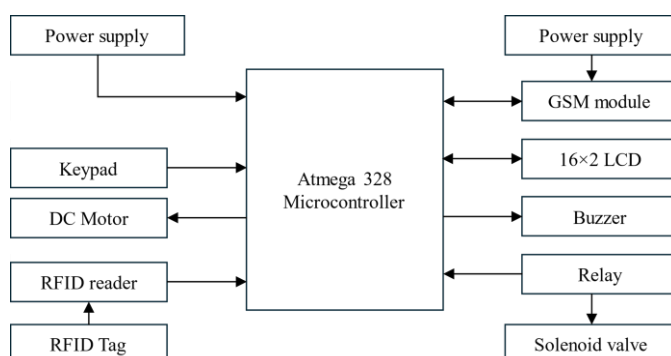

**Figure 1.** Block diagram of the proposed system.

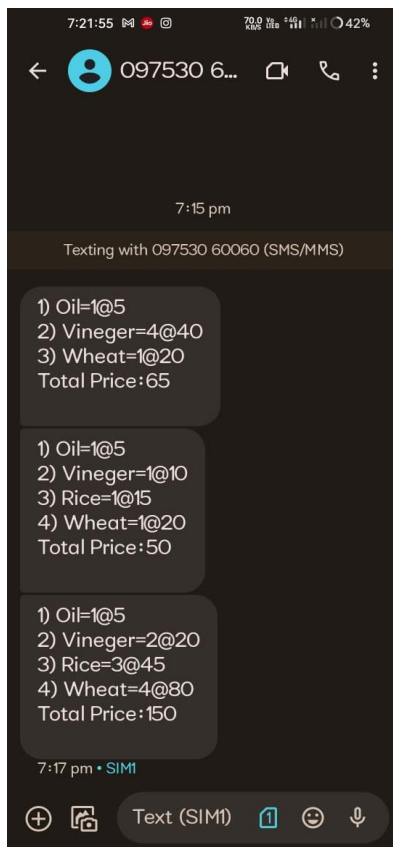

**Figure 2.** User notification interface.

4. *Resilience*: By facilitating quick reaction, resource mobilization, and adaptive management, E-Rationing systems increase the resilience of food delivery networks in places vulnerable to natural disasters or armed conflict. Redundancy measures and cloud-based data storage guarantee data availability and integrity even under difficult circumstances.

## CONCLUSIONS

Smart Ration card system is based on GSM & RFID instead of ration card through which the controller will send the information to the customer & this same information will be updated on web page. By using this system, we can avoid corruption in ration or public distribution system to some extent:

- Efficiency.
- Transparency.
- Accuracy.
- Security.
- Accessibility.
- Scalability.

The surveyed papers collectively contribute to advancing the field, paving the way for more efficient and reliable for E-Rationing System.

## REFERENCES

1. “Bhatnagar, S., Singh, D., & Singh, M. (2018). Design of E-Ration Card System using RFID and Biometric Technologies. *International Journal of Computer Applications*, 179(10), 35-41
2. “Verma, V., Kaur, J., & Singh, K. (2019). An Innovative Approach for E-Ration Card Management System using RFID Technology. *International Journal of Engineering and Advanced Technology*, 8(5), 492-495.

3. “Singh, A. K., Sahu, S. K., & Katiyar, V. (2018). Design and Implementation of Smart Ration Card System using RFID and GSM Technologies. *International Journal of Computer Applications*, 181(21), 1-5.
4. “Shukla, N., & Tiwari, R. (2019). E-Ration Card Management System using IoT and RFID. *International Journal of Computer Science and Mobile Computing*, 8(10), 100-107.
5. “Agrawal, S., & Yadav, S. K. (2017). An Efficient and Secure E-Ration Card System using RFID and Biometric Technology. *International Journal of Computer Applications*, 168(4), 38-43
6. “Amitangshu Pal and Krishna Kant, “Smartporter: a combined perishable food and people transport architecture in smart urban areas,” in 2016 IEEE International Conference on Smart Computing (SMARTCOMP), IEEE, May 2016.
7. “R. Padmavathi, K. M. M. Azeezulla, P. Venkatesh, K. K. Mahato, and G. Nithin, “Digitalized Aadhar enabled ration distribution using smart card,” 2017 2nd IEEE International Conference on Recent Trends in Electronics, Information & Communication Technology (RTEICT), Bangalore, 2017
8. “Supriya Lokhande, Sagar Shinde, “Review on Smart Ration Distribution System,” *International Journal of Computer Sciences and Engineering*, Vol.7, Issue.6, pp.1221-1223, 2019.
9. Kumbhar Aakanksha, Kumavat Sukanya, Lonkar Madhuri, Mrs. A.S. Pawar, “Smart Ration Card System Using Raspberry-pi”, *International Journal of Advanced Research in Computer and Communication Engineering*, Vol. 5, Issue 4, April 2016
10. K. Balakarthish, Closed-Based Ration Card System Using RFID and GSM Technology, vol. 2, no. 4, Apr 2013. *IEEE Xplore*.