

# Design and Implementation Solar-based Uninterruptible Power Supply System

Princi<sup>1</sup>, Rachit Srivastava<sup>2\*</sup>, Tanvi<sup>3</sup>, Vipin Kumar<sup>4</sup>, Shivam Rajput<sup>5</sup>, Arun Kumar Yadav<sup>6</sup>

## Abstract

*The increasing reliance on continuous power supply in various sectors necessitates innovative solutions to address power outages and reduce dependency on conventional energy sources. The design and execution of a solar-powered uninterruptible power supply (UPS) system are presented in this study. The system integrates photovoltaic (PV) panels, a battery storage unit, and an inverter to ensure a seamless power supply during grid failures. With the use of an inverter, the PV panels transform sunlight into alternating current that is stored in capacitors and utilized for running necessary loads. This setup not only provides an eco-friendly alternative to traditional UPS systems but also reduces operational costs by harnessing renewable energy. The system's performance was evaluated under different conditions, demonstrating its reliability, efficiency, and potential for scalability in residential, commercial, and industrial applications. The findings suggest that solar-based UPS systems offer a sustainable and cost-effective solution for continuous power supply, contributing to energy resilience and environmental sustainability.*

**Keywords:** Solar energy, uninterruptible power supply, photovoltaic panels, battery storage, renewable energy, power continuity

## INTRODUCTION

An uninterruptible power supply (UPS) is a gadget that supplies electronic equipment with backup power in case of a major power outage or fluctuation. This ensures that connected devices can continue operating for a short period, allowing for a safe shutdown, or bridging of the gap until the backup generator kicks.

Rural and suburban areas in India continue to experience an unparalleled energy crisis. Summertime brings about serious issues. Winter, however, was the same, with an average of three to four hours of power outages per day. During these disruptions, those without generators or UPS systems encounter severe difficulties. Due to a substantial rise in demand, the prices of both products continued to rise. Although solar UPSs are not intended to replace them, they can be used as a backup source of energy in the event of a grid outage. It also does not harm the environment. The year-round brightness of the sun was maintained. Estimates of the sun's radiation around the globe have been produced for most countries, including major Indian cities. This information is crucial for designing solar energy conversion systems with the best potential [1, 2].

The incorporation of solar energy into UPS systems has attracted considerable attention because

### \*Author for Correspondence

Rachit Srivastava  
E-mail: [srivastava.rachit94@gmail.com](mailto:srivastava.rachit94@gmail.com)

<sup>1,3-5</sup>Student, Department of Electrical Engineering Bansal Institute of Engineering and Technology Lucknow Uttar Pradesh, India

<sup>2</sup>Assistant Professor, Department of Electrical Engineering Bansal Institute of Engineering and Technology Lucknow Uttar Pradesh India

<sup>6</sup>Associate Professor, Department of Electrical Engineering Bansal Institute of Engineering and Technology Lucknow Uttar Pradesh India

Receiving Date: July 01, 2024  
Accepted Date: July 11, 2024  
Published Date: September 14, 2024

**Citation:** Princi<sup>1</sup>, Rachit Srivastava, Tanvi, Vipin Kumar, Shivam Rajput, Arun Kumar Yadav. Design and Implementation Solar Based Uninterruptible Power Supply System. Journal of Control & Instrumentation. 2024; 15(2): 1–6p.

of the growing need for sustainable and dependable power solutions. Solar-powered UPS systems are promising alternatives to traditional UPS systems, which typically rely on grid power and backup batteries. Advantages and component-solar-based UPS systems integrate photovoltaic (PV) panels, batteries, inverters, and charge controllers to deliver uninterrupted power. The key benefit of these systems lies in their capacity to utilize renewable energy, thereby reducing reliance on fossil fuels and minimizing the carbon footprint [3].

According to Kumar and Kourav [4], solar UPS systems can substantially reduce electricity expenses and offer sustainable power backup solutions for both residential and commercial applications. Technological developments in PV technology and energy storage have improved the efficiency and dependability of solar-based UPS systems [4].

Research conducted by Gupta et al. [5] emphasized the significance of high-efficiency inverters and Maximum Power Point Tracking (MPPT) controllers for optimizing the energy conversion process. These components ensure optimal utilization of solar energy and enhance the overall performance of the UPS system [5].

Moreover, advancements in battery technology, particularly the introduction of lithium-ion batteries, have overcome the limitations of traditional lead-acid batteries. Lithium-ion batteries provide greater energy density, longer lifespans, and superior performance under diverse environmental conditions. Ahmed et al. (2021) illustrated the enhanced durability and efficiency of lithium-ion batteries in solar UPS applications [6].

## METHODOLOGY

The methodology for designing a solar-based UPS system involves several critical steps aimed at ensuring a reliable and efficient power supply that harnesses solar energy. Here is the general outline of the process.

Here, we present a solar-powered UPS system that charges 12 V, 4.7 Ah batteries using solar energy before using the batteries to power an alternating current (AC) load using an inverter. Sun energy was used to charge the 12 V DC battery in this solar-powered UPS system. With the aid of a solar charge controller, the solar panel continuously charged the battery. Once the circuit was turned on, the battery charge was converted from DC to AC with the aid of an inverting circuit, stepping the voltage from 12 V DC to 230 V AC. This system can function independently without the need for an external power source and can be used as a UPS during emergency power outages. A block diagram of the proposed solar-based uninterrupted power supply system is shown in Figure 1.

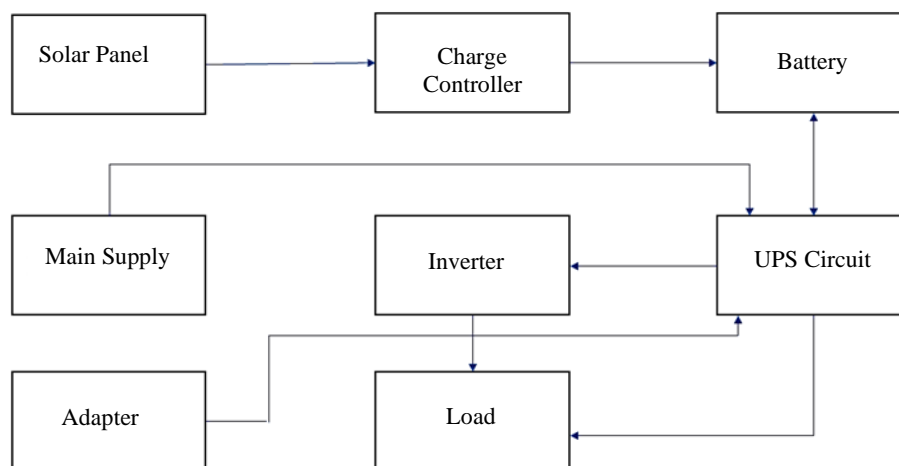

**Figure 1.** Block diagram of proposed solar-based uninterrupted Power Supply system.

## COMPONENT DETAILS

### Solar Panel

Based on the photovoltaic effect, a solar cell, also known as a photovoltaic cell, is an electrical device that directly converts light energy into electricity. The study and technology of using solar cells to generate electricity are known as photovoltaics. The efficiency of solar cells can range from 6% for amorphous silicon-based solar cells to 40.7% for research lab cells with multiple junctions, and 42.8% for hybrid packages comprising multiple dies. Commercially sold multi-crystalline Si solar cells have an energy conversion efficiency between 14 and 19%. Other electrical equipment can also be equipped with solar cells to provide sustained solar power. People can utilize solar camping lanterns, solar bicycle lights, and solar mobile phone chargers daily. An image view of the solar panel used in this system is shown in Figure 2. A 30-watt solar panel with a 12 V voltage rating was utilized in this solar-powered UPS system [7].

### Power Source

A battery is a device that uses an electrochemical oxidation-reduction (or) reaction to directly transform the chemical energy found in its active components into electric energy. Rechargeable batteries are essential in today's world. They supply energy to a multitude of gadgets, ranging from computers and cell phones to electric cars and renewable energy storage systems. Compared to single-use batteries, these batteries are more financially and environmentally favorable because of their capacity to charge and discharge multiple times. A pictorial view of the solar panel is shown in Figure 3. An 8 Ah lead-acid battery was used in this project. The battery had a voltage rating of 12 V [8].



**Figure 2.** Picture view of solar panel.



**Figure 3.** Picture view of Battery.

### Controller for Charge

In small-scale solar energy systems, a 12 V charge controller is essential for guaranteeing the effective and secure charging of solar panel batteries. It controls the voltage and current from the solar panels to the batteries, avoiding deep draining and overcharging while preserving the integrity of the batteries. The main task of the charge controller is to control the power flow from the solar panel to the battery bank. Depending on the sunshine, solar panels can provide different quantities of power, which, if uncontrolled, can damage the batteries. By supplying the batteries with a consistent and suitable voltage and current, a 12 V charge controller prolongs the life of the batteries and preserves the system's efficiency. A visual view of the charge controller is shown in Figure 4 [9].

### Inverter

The purpose of an inverter is to transform a direct current (DC) into an AC. The current generated by a solar panel or battery is called DC. This functionality is crucial in various applications, from powering household appliances using battery storage systems to enabling renewable energy integration and industrial automation. The input supply was 12 V DC whereas the output voltage was 12 V AC. Figure 5 shows a photograph of the inverter view [10].

### Hardware Implementation and Operation

Using a charge controller circuit, solar panels are used to continuously charge a 12 V DC battery. The 12 V battery output is then applied to the inverter input when the switch is turned on. After the inverter converts 12 V DC to 12 V AC, a step-up transformer helps to raise the voltage to 230 V AC before the power is sent to the load. The hardware of the solar-powered UPS system is shown in Figure 6.



Figure 4. Picture view of the charge controller.

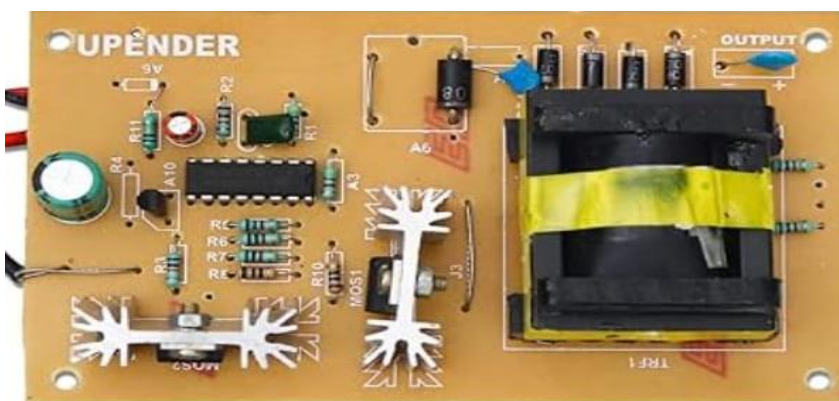
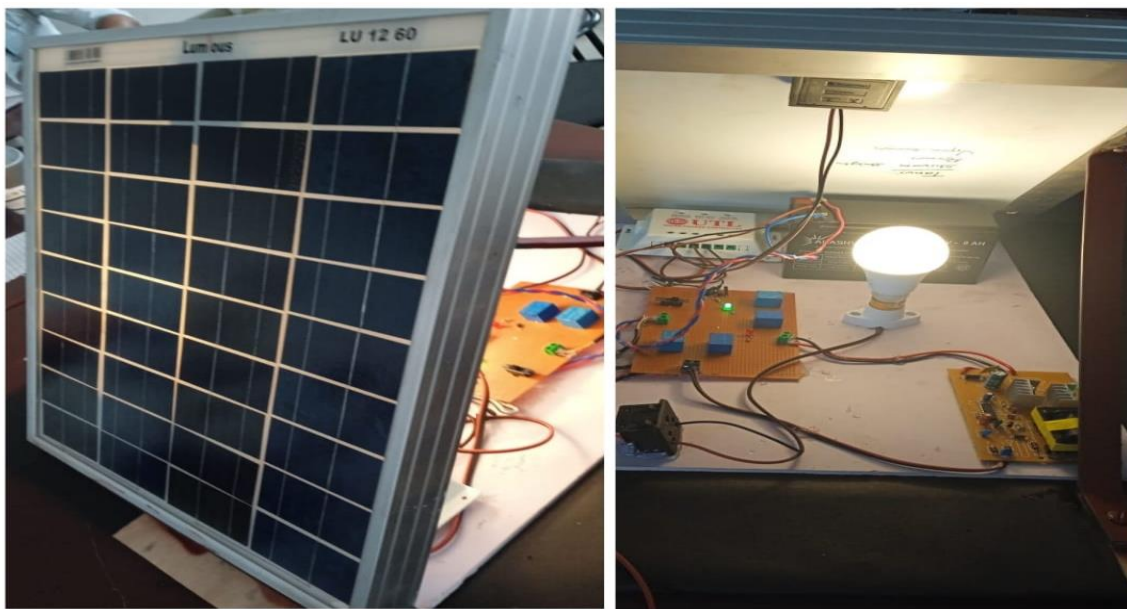

Figure 5. Picture view of inverter.

- *Energy generation:* Sunlight is absorbed by solar panels, which are then transformed into DC electricity. The charge controller receives this electrical power.
- *Energy regulation:* Power from the solar panels is transferred to the batteries under the supervision of a charge controller. The current generated by the solar panel or battery is called DC. It guarantees that the batteries are charged to their ideal level, guarding against overcharging and preserving battery integrity. Avoiding overcharging and safeguarding battery health ensures that the batteries are charged to their ideal level.
- *Energy storage:* Electrical energy is stored in batteries. The charge controller also prevents the batteries from discharging too much, which can damage them.
- *Power conversion:* When stored DC power is required, the inverter converts it to AC power. The appliances in the home or place of business are then powered by AC.
- *Uninterrupted power supply:* During normal operation, the system powers the load directly from the solar panels or grid while charging the batteries. In the event of a power outage, the UPS unit instantly switches the power supply to the batteries, providing uninterrupted power to the critical loads.

## RESULTS AND OUTCOMES

1. By utilizing solar energy, a source of energy that is renewable and clean, solar-assisted UPS equipment will lessen reliance on non-renewable sources of electricity and its carbon imprint.
2. Over time, the system can lead to significant savings in electricity bills as it generates power from the sun, which is free after the initial setup costs.
3. By adding a solar UPS system, it is less dependent on the grid and can maintain power during outages, thereby ensuring a continuous power supply for critical loads.
4. The system design could allow for scalability, meaning that you can start with a small setup and expand as need grows or as budget allows.
5. This work will contribute to sustainable development goals by promoting clean energy, reducing greenhouse gas emissions, and potentially reducing the use of diesel generators and other polluting sources of backup power.
6. Implementing a solar-based UPS setup can serve as an educational tool for communities, raising awareness of renewable energy benefits and encouraging more widespread adoption.
7. The setup could be integrated with modern energy management for energy consumption, optimizing the use of solar power, and possibly even contributing surplus energy back to the grid.



**Figure 6.** Picture view of the actual hardware setup.

---

## CONCLUSION

The use of solar energy in this work not only provides a reliable emergency power supply but also reduces the carbon footprint and reliance on non-renewable energy sources. Electricity can be created using the sun's energy without consuming limited resources or emitting hazardous pollutants.

Furthermore, the innovative technology used in this study allows for seamless integration with existing electrical systems, ensuring a smooth transition to solar power in times of need. This not only provides peace of mind in emergencies but also promotes sustainability and resilience in the face of power outages.

Overall, the efficiency and reliability of this solar-powered emergency supply system make it an asset for any home or business to prioritize sustainability and preparedness. We can build a more environmentally friendly future for future generations by investing in renewable energy technologies.

## REFERENCES

1. Chauhan DS, Srivastav SK. Non-Conventional Energy Resources. New Delhi: New Age International; 2010.
2. Tiwari GN. Solar Energy: Fundamentals, Design, Modelling and Application. New Delhi: Narosa Publishing House Pvt. Ltd.; 2012.
3. Solanki CS. Solar Photovoltaic Technology and Systems: A Manual for Technicians, Trainers and Engineers. Englewood Cliffs (NJ): Prentice Hall India Learning Private Limited; 2013.
4. Kumar A, Kourav D. Solar powered UPS. J Recent Trends Electr Power Syst. 2021;3(2):73–80.
5. Gupta P, Tripathi S, Singh S, Gupta VS. MPPT-EPO optimized solar energy harvesting for maximizing the WSN lifetime. Peer Peer Netw Appl. 2023;16:347–57. DOI: 10.1007/s12083-022-01405-5.
6. Ahmad MT, Khan S. Energy storage systems for renewable energy sources. In: Smart Energy Management Systems and Renewable Energy Resources. 2021. p. 8-1.
7. Nelson J. Physics of Solar Cells: A Text for Undergraduates. London: Imperial College Press; 2003.
8. Hill CA, Such MC, Chen D, Gonzalez J, Grady WM. Battery energy storage for enabling integration of distributed solar power generation. IEEE Trans Smart Grid. 2012;3:850–7. DOI: 10.1109/TSG.2012.2190113.
9. Jawad AA, Islam MD, Sijan SM, Liya RJ, Nahar LK. Design of Charge Controller for Solar PV Systems [PhD diss.]. Dhaka: Brac University; 2023.
10. Jhapte RK, Zacharia J, Parveen M. Designing of 12V to 220V (150Watt) Compatible Inverter for Small Rating Appliances with Hand Driven Generator and Solar Panel Installed. 2022.