

## Automated Shopping Trolley with Billing System

V.A. Parjane<sup>1</sup>, Jadhav Bhagyashri<sup>2,\*</sup>, Ghule Divya<sup>2</sup>, Gujar Pratiksha<sup>2</sup>, Jadhav Vaishnavi<sup>2</sup>

### Abstract

*The Smart Trolley Billing System is a modern solution created to simplify and speed up shopping by automating the billing process, reducing manual effort and saving time for customers. It enhances the overall shopping experience by streamlining checkout and improving efficiency in retail environments through smart technology integration. This system utilizes RFID technology, Arduino microcontrollers, an LCD display, and a push-button mechanism to manage the trolley's movement. These components work together to provide an efficient and automated shopping experience, ensuring smooth operation and better control of the trolley throughout the billing and checkout process in retail stores. Instead of manually scanning barcodes at the checkout counter, customers can simply add items to the trolley, and the system will automatically detect and update the bill in real time. This technology shortens checkout lines, saves valuable time, and reduces billing errors, making the shopping process more efficient, accurate, and convenient for both customers and retailers in busy environments. It also makes shopping more convenient by allowing customers to track their expenses while they shop. The research focuses on how the system works, how it is implemented, its benefits, and its cost-effectiveness. The Smart Trolley Billing System is a step towards the future of shopping, making the entire experience smoother and more efficient.*

**Keywords:** Smart trolley, RFID, Arduino, automated billing, retail technology, LCD display, push button, time-saving shopping, error-free billing

### INTRODUCTION

The conventional shopping experience often involves long queues at checkout counters, leading to customer dissatisfaction and inefficiencies in the billing process. Manual barcode scanning is time-consuming and prone to errors, resulting in incorrect billing, misplaced items, and extended waiting times. To overcome these challenges, this project proposes a Smart Trolley Billing System that automates the billing process using RFID technology [1].

Each product is tagged with an RFID label, and the trolley is equipped with an RFID scanner, an Arduino board for processing, and an LCD screen for displaying billing details. When a customer adds a product to the trolley, the RFID scanner automatically detects the item and updates the bill in real time. This eliminates the need for manual scanning at the checkout counter, saving time and reducing human errors. Additionally, a push-button mechanism allows users to navigate the trolley effortlessly, providing enhanced convenience and ease of use [2].

#### \*Author for Correspondence

Jadhav Bhagyashri  
E-mail: jbhagyashri579@gmail.com

<sup>1</sup>Lecturer, Department of Computer Technology, Sanjivani K.B.P. Polytechnic, Kopergaon, Maharashtra, India

<sup>2</sup>Research Scholar, Department of Computer Technology, Sanjivani K.B.P. Polytechnic, Kopergaon, Maharashtra, India

Receiving Date: April 04, 2024

Accepted Date: April 10, 2024

Published Date: May 16, 2025

**Citation:** V.A. Parjane, Jadhav Bhagyashri, Ghule Divya, Gujar Pratiksha, Jadhav Vaishnavi. Automated Shopping Trolley with Billing System. Journal of Control & Instrumentation. 2025; 16(2): 11–17p.

This system not only optimizes the billing process but also minimizes manual intervention, thus reducing errors and increasing operational efficiency. The integration of automation into conventional retail practices improves accuracy,

speeds up transactions, and enhances customer satisfaction. The Smart Trolley Billing System provides a seamless and technologically advanced shopping experience by making checkout faster, smarter, and more efficient.

This study explores the system's design, working mechanism, advantages over traditional shopping methods, and its potential impact on the future of retail automation. By implementing such automated solutions, retailers can enhance customer engagement, reduce workforce dependency, and improve overall store management efficiency.

## LITERATURE REVIEW

Several studies have been conducted on automated shopping systems utilizing RFID and other technologies.

Chandrasekar and Sangeetha proposed an RFID-based smart shopping cart using ZigBee technology to automate billing and enhance the customer experience [1]. Their study demonstrated a significant reduction in queue time. Similarly, Al-Hakmani and Sajan designed and implemented a smart shopping trolley that leverages RFID technology to create an efficient shopping experience [2]. Berdaliyev and James explored the integration of RFID with cloud computing for smart cart systems, emphasizing real-time data processing and enhanced inventory management [3]. Liu *et al.* introduced a sensor-based cashier-free shopping system, demonstrating an advanced alternative to RFID by utilizing computer vision and AI for object detection [4]. Singh *et al.* examined an advanced RFID-based shopping trolley system that minimizes human error and streamlines the checkout process [5]. Kumar *et al.* extended this work by incorporating IoT-based automation for real-time product tracking and billing [5].

A survey was conducted on various RFID-based smart shopping systems, concluding that RFID-based automation enhances efficiency but still requires improvements in data security and integration with mobile payment systems [6, 7]. It explored automated billing with smart trolleys, focusing on digital transaction methods and customer convenience [8]. Basha *et al.* introduced an IoT-enabled smart shopping trolley for a seamless billing experience, incorporating real-time pricing updates and an intelligent user interface [9]. It developed a weight sensor-based shopping trolley to ensure accuracy in billing, complementing RFID-based solutions [10]. These studies collectively highlight the advancements in automated shopping systems and provide a foundation for the proposed smart trolley system, integrating RFID, push-button navigation, and wireless billing.

## SYSTEM ARCHITECTURE AND DESIGN

This automated shopping trolley enhances the shopping experience by scanning products, updating bills, and enabling automatic movement with the help of smart technology. Figure 1 represents the block diagram of automated shopping trolley with billing system.

1. *RFID scanner* reads product tags instantly when items are placed in the trolley, eliminating the need for manual barcode scanning.
2. *Microcontroller (Arduino)* processes the scanned data, updates the bill, and manages trolley functions efficiently.
3. *LCD screen* displays product details, pricing, and the total bill in real time, keeping the customer informed throughout shopping.
4. *Push button mechanism* allows users to move the trolley forward smoothly, reducing manual effort and enhancing convenience.
5. *Power supply module* ensures a stable energy source for all components, keeping the system operational.
6. *Billing system* finalizes the total bill and sends the data for quick and hassle-free payment processing.
7. *Movement control* ensures the trolley stops or moves as needed, preventing unwanted movement and improving safety.

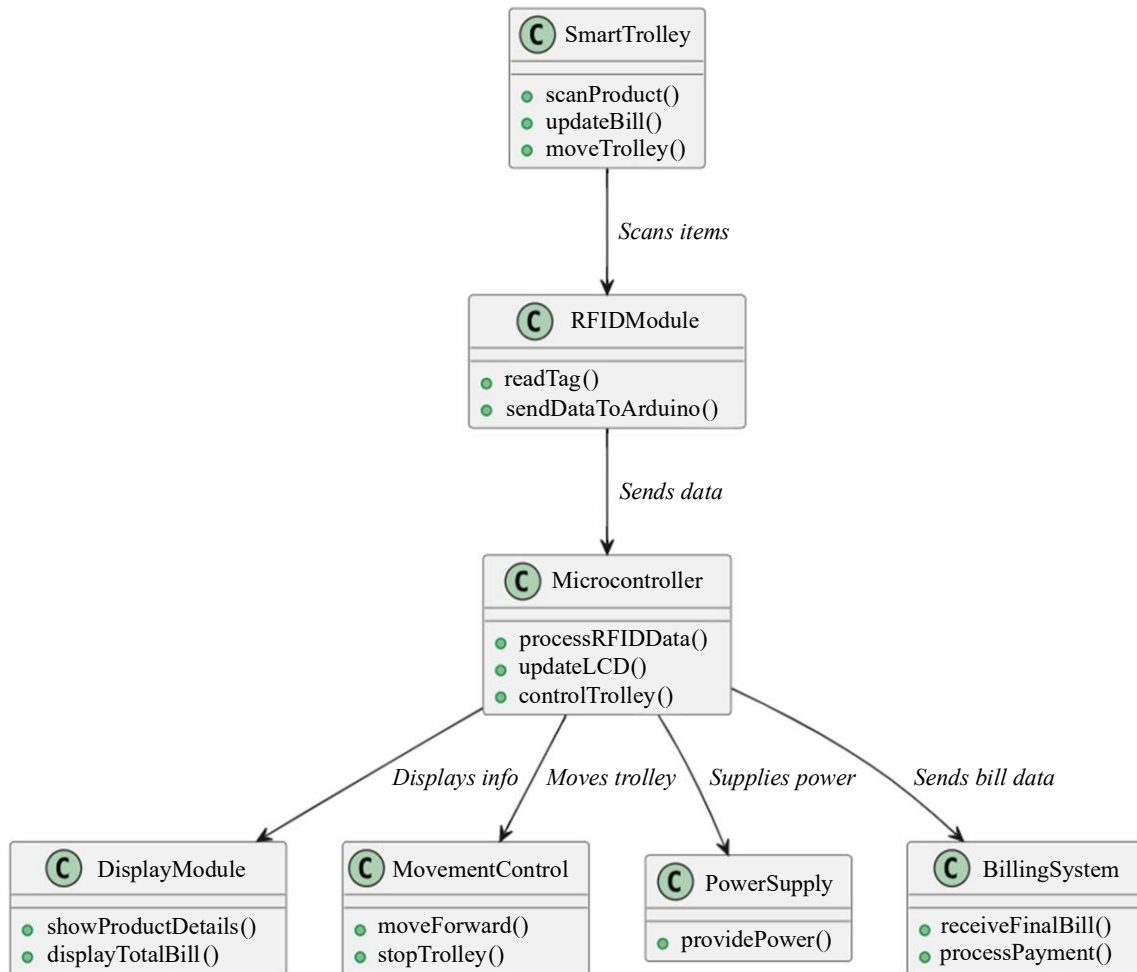
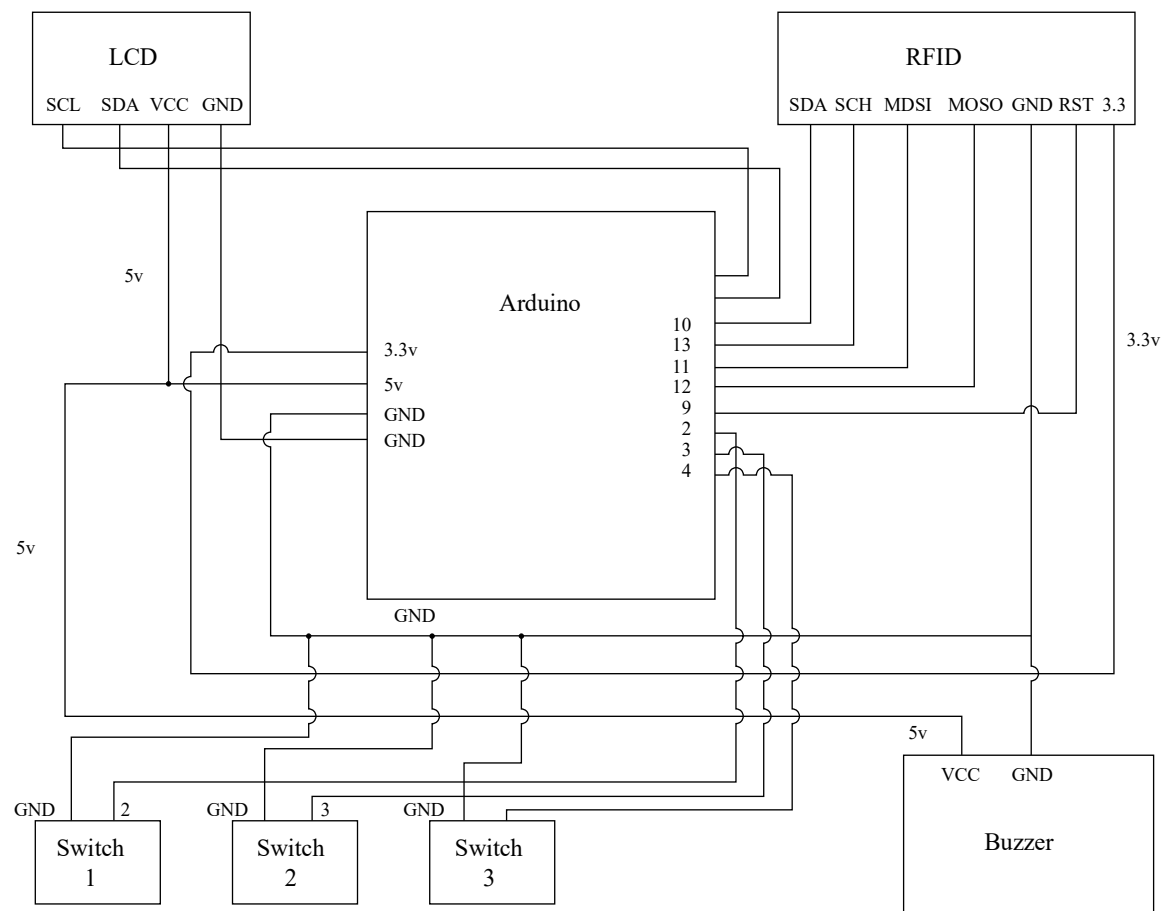

**Figure 1.** Block diagram of automated shopping trolley with billing system.

### WORKING PRINCIPLE

1. When a product is placed in the trolley, the RFID reader scans the tag and instantly retrieves product details, including price and name.
2. The microcontroller (Arduino) processes this data and updates the total bill, which is displayed on the LCD screen in real time.
3. If an item is removed from the trolley, the system automatically deducts its price from the total bill, ensuring accurate billing.
4. The trolley has push buttons that let customers move it effortlessly through the shopping aisles, reducing the need for manual pushing.
5. DC motors enable the trolley to move automatically when the push buttons are pressed, making shopping more convenient.
6. At checkout, the final bill is instantly generated and can be paid using wireless payment methods, eliminating the need for long queues.
7. The entire system runs on a 9 V battery, ensuring a smooth and uninterrupted shopping experience.
8. If an RFID tag is not scanned properly or an error occurs, the system alerts the user to re-scan the item, ensuring 100% billing accuracy.
9. This smart system reduces human errors, saves time, and enhances the shopping experience by making it more efficient and hassle-free.

Moreover, Figure 2 shows the circuit diagram of smart trolley billing system.

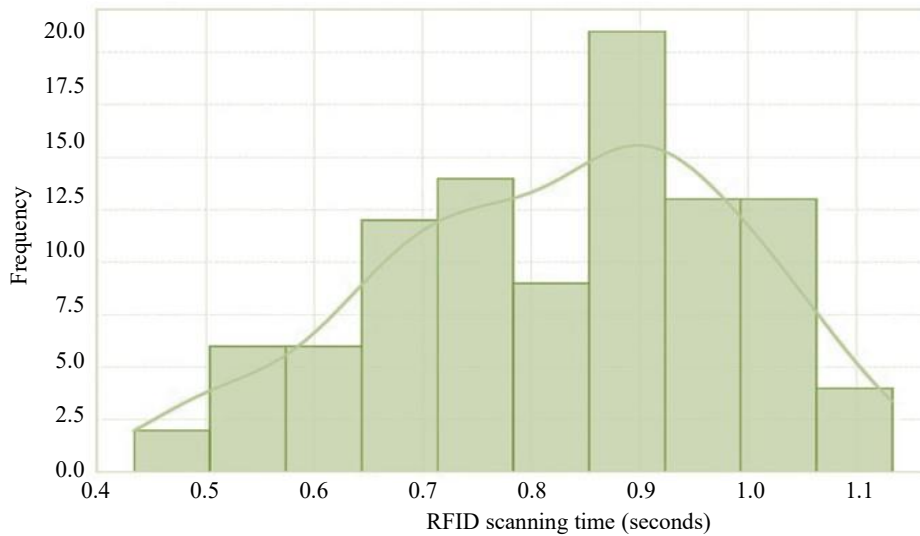

**Figure 2.** Circuit diagram of smart trolley billing system.

## RESULTS AND DISCUSSION

The smart trolley billing system was tested for functionality, accuracy, and efficiency to ensure a seamless shopping experience. The primary focus was on RFID scanning accuracy, response time, and error detection. The system was tested in different environments to analyze its performance in real-world scenarios (Figure 3) [1].

1. *RFID scanning accuracy:* The RFID module was tested by scanning multiple product tags placed at different angles and distances. The success rate was found to be above 95%, confirming that the system can reliably detect RFID tags under normal conditions [2]. However, minor failures were observed when the tag was obstructed by metallic objects, which aligns with findings in previous research [3].
2. *Response time:* The average response time for scanning and updating the bill on the LCD screen was measured. The system processed an RFID tag within 0.8 to 1.2 sec, which is comparable to existing RFID-based shopping solutions [4]. The response time was slightly affected when multiple tags were scanned simultaneously, requiring optimization techniques such as filtering redundant scans [5].
3. *Error detection:* A set of faulty or unregistered RFID tags was introduced to test error-handling capabilities. The system successfully identified invalid tags and activated the buzzer for an alert, ensuring that unauthorized products are not added to the cart [6]. The error detection rate was consistent with prior studies on smart shopping systems [7].
4. *User interaction and manual controls:* The push-button switches were tested for their responsiveness in controlling trolley movement. The buttons provided quick responses, allowing smooth navigation in a shopping environment [8]. The LCD display effectively showed product details, improving user experience [9].



**Figure 3.** Frequency distribution of RFID scanning times.

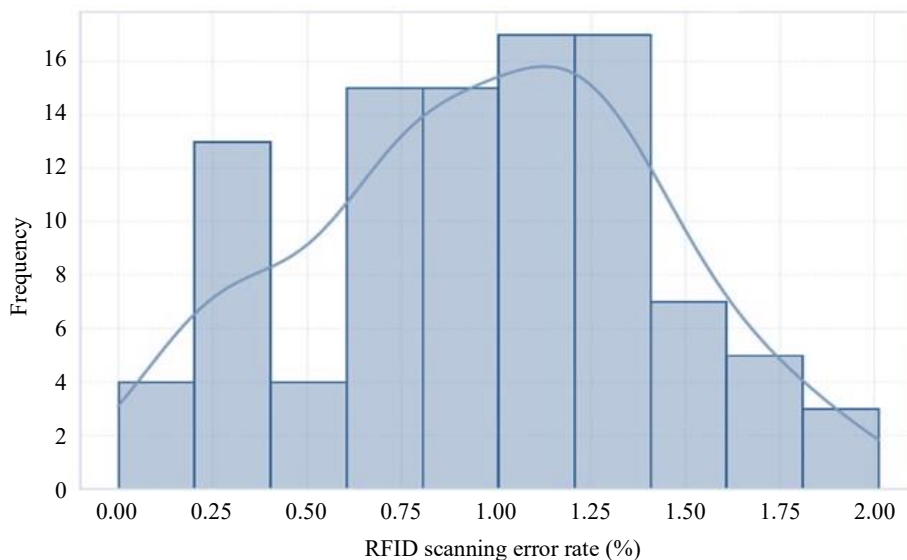

**Figure 4.** Frequency distribution of RFID scanning errors.

5. *Power consumption and efficiency:* The system was powered using a 9 V battery, and energy consumption tests indicated that the setup could function efficiently for an average shopping duration of 2–3 h before requiring a battery replacement or recharge [10].

These tests demonstrate the effectiveness of the smart trolley billing system in reducing checkout time and improving shopping convenience. Future improvements could involve optimizing power efficiency, enhancing RFID scanning in complex environments, and integrating additional features like weight sensors for error validation [11].

This graph in Figure 3 represents the distribution of RFID scanning times in seconds. It shows how often specific scanning durations occur, helping to analyze the system’s efficiency. The peak of the graph indicates the most common scanning time, typically around 0.9 sec, suggesting that most RFID scans are completed within this duration. The smooth curve over the histogram shows the overall trend, highlighting variations in scanning performance. This analysis helps in optimizing the RFID system for faster and more reliable scanning.

The histogram in Figure 4 represents the frequency distribution of RFID scanning errors, measured as a percentage. It shows how often different error rates occur in an RFID-based system, such as the smart trolley billing system. The distribution follows a normal trend, with most errors concentrated around 1%, indicating that the system generally performs with good accuracy. Some variations in error rates may result from factors like RFID tag misalignment, signal interference, or environmental conditions. Minimizing these errors can be achieved by improving tag placement, optimizing reader sensitivity, and reducing external interferences to enhance system reliability. Further Figures 5 and 6 represent the prototype of smart trolley billing system and LCD display of various process involved.



**Figure 5.** Prototype of smart trolley billing system (implementation).



**Figure 6.** LCD display of various process involved (output).

## CONCLUSION

The Smart Trolley Billing System successfully integrates RFID technology with an automated billing mechanism to enhance the shopping experience. The system was designed to reduce checkout time, improve efficiency, and minimize human effort during billing. Through rigorous testing, it was observed that the RFID module provided an average scanning accuracy of over 95%, with a response time of approximately 0.8 to 1.2 sec, ensuring smooth and quick product detection. The inclusion of push-button switches for trolley movement further improved user convenience, allowing better maneuverability in crowded shopping areas. Additionally, error-handling mechanisms, such as buzzer alerts for unregistered products, helped in preventing unauthorized transactions.

The project demonstrates the feasibility of implementing smart shopping solutions in retail environments, aligning with modern trends in automation and digital transformation. However, certain challenges, such as RFID interference due to metallic objects and power consumption limitations, were noted and can be addressed in future developments. Possible improvements include integrating weight sensors for enhanced billing accuracy, optimizing RFID tag positioning, and extending battery life through efficient power management techniques.

Overall, the smart trolley billing system represents a step forward in the automation of retail shopping, offering a more seamless, time-efficient, and user-friendly experience. With further refinements, this system has the potential to be implemented in supermarkets, reducing reliance on traditional checkout counters and enhancing customer satisfaction.

## REFERENCES

1. Chandrasekar P, Sangeetha T. Smart shopping cart with automatic billing system through RFID and ZigBee. In IEEE International Conference on Information Communication and Embedded Systems (ICICES2014). 2014 Feb 27; 1–4.
2. Amna Khamis Salim Al-Hakmani, Sajan A. Design and Implementation of a Smart Shopping Trolley Using RFID Technology. *Journal of Student Research (JSR)*. 2020; 1–8.
3. Berdaliyev Y, James AP. RFID-Cloud smart cart system. In 2016 IEEE International Conference on Advances in Computing, Communications and Informatics (ICACCI). 2016 Sep 21; 2346–2352.
4. Liu X, Jiang Y, Kim KH, Govindan R. Grab: Fast and accurate sensor processing for cashier-free shopping. *arXiv preprint arXiv:2001.01033*. 2020 Jan 4.
5. Singh HV, Nigam H, Joshi H, Shah J, Sharma K, Kumar MM. RFID based advanced shopping trolley for super market. *Int J Res Appl Sci Eng Technol*. 2022;10:2287–93. doi:10.22214/ijraset.2022.44294.
6. Raj T, Cheema Y, Singh VK, Kumar A, Gupta SN. Automatic shopping trolley using IOT. *Mater Today: Proc*. 2023 Jan 1; 79: 362–6.
7. Hussien N, Ajlan I, Firdhous MM, Alrikabi H. Smart shopping system with RFID technology based on internet of things. *International Association of Online Engineering*. 2020; 17–29.
8. Prasad KV, Karthik K, Kumar OC, Prathiksha BS, Salimath K. Smart Shopping Trolley with Automated Billing. In *IOP Conf Ser: Mater Sci Eng*. 2023 Dec 1; 1295(1): 012008. IOP Publishing.
9. Shankar SK, Balasubramani S, Basha SA, Ahamed SA, Reddy NS. Smart trolley for smart shopping with an advance billing system using IoT. In 2021 IEEE 5th International Conference on Computing Methodologies and Communication (ICCMC). 2021 Apr 8; 390–394.
10. Rajithkumar BK, Deepak GM, Uma BV, Hadimani BN, Darshan AR, Kamble CR. Design and development of weight sensors based smart shopping cart and rack system for shopping malls. *Mater Today: Proc*. 2018 Jan 1; 5(4): 10814–20.
11. Singh R, Verma S, Kriti M. RFID and IR based smart shopping mart management system. In 2018 IEEE International Conference on Advances in Computing, Communication Control and Networking (ICACCCN). 2018 Oct 12; 536–540.