

An Evaluation of CNN and SVM Algorithms for Facial Recognition

Pooja P. Raj^{1*}, Dr. Amrita Verma²

Abstract

With the use of facial recognition technology, someone's identity can be confirmed or identified. Real-time or picture-based facial recognition technology can be used to identify individuals. One of the most important elements in the field of biometric security is facial recognition. The technology is mostly used in the fields of law enforcement and defence, while interest in other fields is growing. To recognize the face, numerous technologies and algorithms were developed and used. In this paper, we will study two algorithms that are CNN and SVM for detecting face and analysis the best algorithm between the two. This work is organized into sections: an introduction, a face detection methods section, face detection using algorithms, and a result and conclusion section.

Keywords: CNN, SVM, Face Detection, Landmark, dlib

INTRODUCTION

A digital photo or video frame may contain a person's face that can be compared to a database of faces using technology called a facial recognition system. This kind of equipment finds and measures facial features from a picture, usually in the context of confirming users' identities through ID verification services. Although it doesn't take much for people to identify faces, facial identification is a difficult pattern recognition challenge in computing. Based on a two-dimensional image, facial recognition systems try to identify a human face, which is three-dimensional and changes appearance with lighting and facial emotion. Four steps are taken by facial recognition systems in order to complete this computational task. Face detection is utilised first in order to extract the face from the backdrop of the image. The segmented face picture is aligned in the second phase to take into consideration the size of the image, the facial attitude, and photography characteristics like grayscale and illumination. In the third stage, known as facial feature extraction, the alignment technique serves to facilitate the precise localization of facial features [4].

*Author for Correspondence

Pooja P. Raj
E-mail: poojaraj9421@gmail.com

¹Research Scholar, Department of Computer Science & Engineering, Dr. C.V. Raman University, Bilaspur, Chhattisgarh, India

²Associate Professor, Department of Computer Science & Engineering, Dr. C.V. Raman University, Bilaspur, Chhattisgarh, India

Received Date: March 14, 2024

Accepted Date: March 20, 2024

Published Date: April 20, 2024

Citation: Pooja P. Raj, Amrita Verma. An Evaluation of CNN and SVM Algorithms for Facial Recognition. International Journal of Machine Systems and Manufacturing Technology. 2023; 1(2): 12–19p.

The combination of facial recognition technologies with artificial intelligence helped a lot to detect faces. Artificial intelligence (AI) software is capable of instantly searching face databases and comparing them to one or more faces that are identified in a scenario [5]. Thus we can obtain very accurate findings quickly; on public standard data sets, systems often yield higher accuracy rates. Software for AI facial recognition offers the following benefits: Identification in real time; countermeasures against spoofing; reduced prejudice in terms of race or gender as a result of model training on millions of faces; and also is applicable to several cameras [6].

Applications of Facial Detections

- *Medical attention:* AI and computer vision are coupled to track patient medication consumption and assist with pain management methods.
- *Safety:* Deep learning algorithms are contributing to improved anti-spoofing capabilities, fraud detection, and a decrease in the requirement for frequent passwords on mobile devices.
- *Airport Boarding:* Airports have started implementing "smart gates," which combine liveliness and facial recognition technology, to expedite processes.
- *Proctoring:* Using webcam surveillance, certain proctor services employ AI technologies to identify and record questionable behavior. The occurrences can then be contextualized and analyzed by live proctors [7].

HOW TO DETECT FACE

Face Detection can be done at three levels as specified (Figure 1):

Detection

When computer vision is enabled, faces in photos with one or more human faces can be recognised and identified individually by facial recognition software. Face profiles and face data can be detected by it. Computer vision enables machines to quickly and efficiently identify persons, locations, and objects in photos with accuracy on par with or higher than that of humans. Computer vision extracts meaningful information from picture input through classification, analysis, processing, and comprehension using cutting-edge artificial intelligence (AI) technologies [8].

Analysis

The facial recognition system reads the shape and geometry of the face as it analyses it. In addition to more, it finds significant facial traits for face recognition. The face print, also known as landmarks, is a sequence of numbers or dots created by the system from face recognition data. Each person's face is as distinct as their fingerprint. There are additional applications for this facial recognition data, such as digital face reconstruction [9].

Standard face datasets offer annotations of 68 x and y coordinates that represent an individual's most notable facial traits. One popular open source library that can identify these landmarks in a picture is called Dlib [10, 11]. The landmarks of a sample image is shown Figure 2.

Recognition

By comparing the faces of two or more photographs and determining the likelihood of a face match, face recognition technology may recognise an individual. For instance, it can confirm that the face displayed in an image taken with an electronic device's camera is the same as the face displayed in an official government photo, like an aadhar card or driver's licence or voter id [13-17].



Figure 1. Levels of face detection.

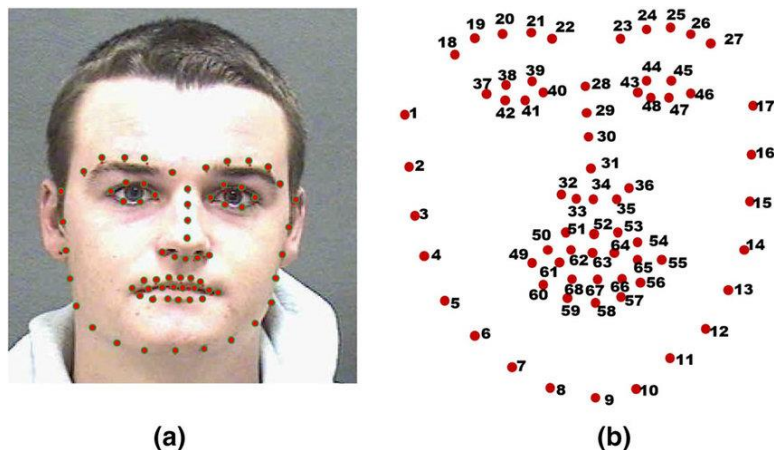

Figure 2. Landmark of a face [2].

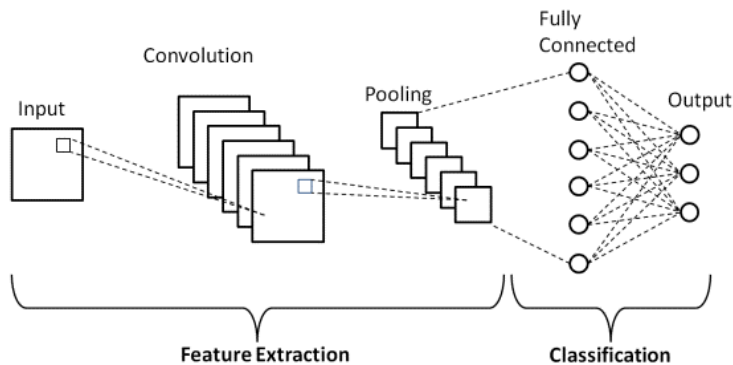

Figure 3. Architecture of CNN [12].

ALGORITHMS FOR FACE DETECTION

In this study of face detection two algorithms were used they are CNN and SVM.

CNN

One kind of deep learning algorithm created especially for image processing and recognition applications is the convolutional neural network (CNN). Since CNNs are able to learn hierarchical representations of features from raw images that are input, they require less setup than traditional classification methods. With the help of convolutional layers—which use filters to identify local patterns—they are excellent at determining the relative relevance of different objects and attributes inside the images. The visual cortex in the human brain, where neurons react to particular areas or receptive fields in the visual environment, serves as an inspiration for the connection pattern in CNNs [18-20]. CNNs are able to recognize spatial relationships and patterns in images thanks to this architecture. Multiple convolutional and pooling layers are stacked to enable CNNs to learn more complicated features with high accuracy (Figure 3) [1].

SVM

Regression and classification are two applications of Support Vector Machine (SVM), a supervised machine learning method. Still, classification problems are the best situations to use regression problems. The SVM method's primary goal is to identify the best hyperplane in an N-dimensional space for dividing data points into various feature space classes [21,22]. The hyperplane seeks to maintain as large a buffer as it can between the nearest points belonging to various classes. How many features there are determines the hyperplane's dimension. The hyperplane may be conceptualized as a line when input characteristics are restricted to two (Figure 4). The hyperplane transforms into a 2-D plane upon input of three attributes [3].

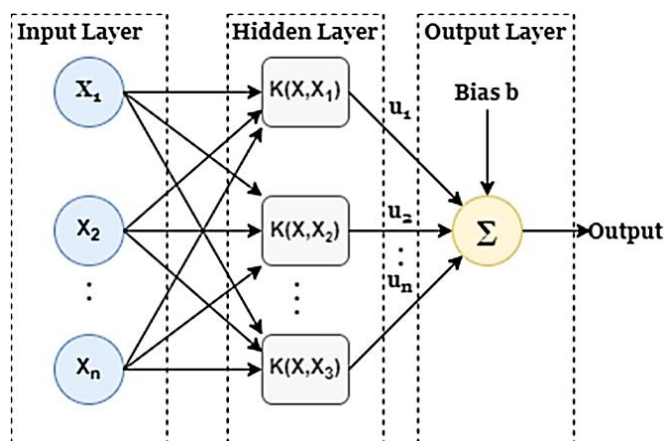

Figure 4. Architecture of SVM [15].

DATASET AND EXPERIMENTAL SETTINGS

In this study between the two algorithms CNN and SVM Kaggle dataset was used specifically:

1. **ORL Datasets:** There are 400 pictures from 40 different subjects in the ORL Database of Faces. Depending on the illumination, subjects' facial emotions (open or closed eyes, smiling or not smiling), and face details (glasses or not) were captured at different periods for some people. Each picture featured a uniformly dark background and featured persons standing straight ahead, allowing for slight deviation to either side [23]. Each image has 256 grey levels per pixel and is 92 by 112 pixels. The dataset can be found with the help of this link: <https://www.kaggle.com/datasets/kasikrit/att-database-of-faces> [15].
2. **LFW Datasets:** a collection of face photos intended for research on the issue of unrestricted face identification. The data collection encompasses around 13,000 photos of faces that were collected from the internet. Each person's face in the photo has their name inscribed on it. In the data set, 1680 individuals have two or more unique photographs. These faces are only limited by the fact that the Viola-Jones face detector identified them. The dataset can be downloaded from this link: <https://www.kaggle.com/datasets/atulanandjha/lfwpeople> [37].

We have employed SVM and CNN in python and the dataset can include undesired information and noise. We may prevent this by using Dimensionality Reduction strategies, which assist us in reducing the dataset's complexity and taking into account just relevant information rather than unimportant information we are using the PCA (Principal Component Analysis) [24-30].

Basic Procedure for face detection involves various steps:

Firstly dataset is loaded then face selection and preprocessing is done. After this algorithm is selected for the evaluations and validations. After this model is trained and tested (Figure 5).

RESULT AND CONCLUSION

Both the model has been trained and tested for the datasets with 150 epochs. While training the model with CNN and SVM the accuracy rate is as follow Table 1:

From the above comparison of the two algorithms, we find that the SVM model gave better accuracy rate compared to CNN [31-37].

Table 1. Comparison table for face detection.

S.N.	Algorithm Used	Accuracy Rate
1	CNN	65%
2	SVM	83%

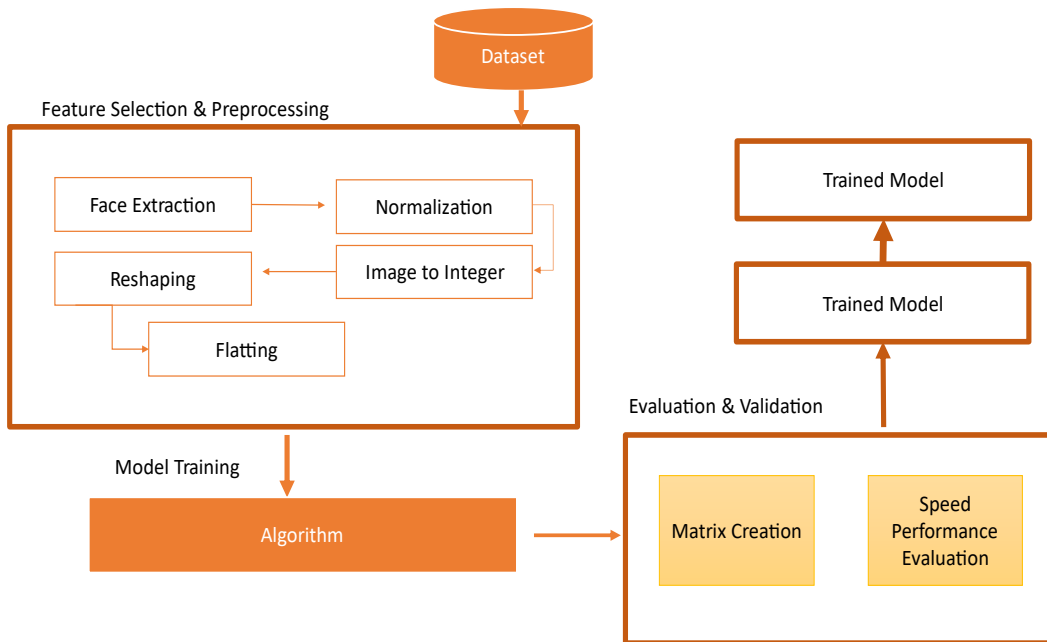

Figure 5. Procedure for face detection [1].

REFERENCES

1. Raj, Pooja P, and Verma, Amrita, 'Comparative Study of Face Mask Detection Using CNN and SVM Algorithms', 14.03 (2023)
2. Datagen. (2023, 04 04). Datagen. Retrieved from Datagen: <https://datagen.tech/guides/face-recognition/facial-landmarks/>
3. kit, M. (2023, 01 01). ML Kit. Retrieved from ML Kit: <https://developers.google.com/ml-kit/vision/face-detection>
4. Aung, Htet, Alexander V. Bobkov, and Nyan Lin Tun, 'Face Detection in Real Time Live Video Using Yolo Algorithm Based on Vgg16 Convolutional Neural Network', in 2021 International Conference on Industrial Engineering, Applications and Manufacturing (ICIEAM) (presented at the 2021 International Conference on Industrial Engineering, Applications and Manufacturing (ICIEAM), Sochi, Russia: IEEE, 2021), pp. 697–702 <https://doi.org/10.1109/ICIEAM51226.2021.9446291>.
5. Hyun, Jongkil, Junghwan Kim, Cheol-Ho Choi, and Byungin Moon, 'Hardware Architecture of a Haar Classifier Based Face Detection System Using a Skip Scheme', in 2021 IEEE International Symposium on Circuits and Systems (ISCAS) (presented at the 2021 IEEE International Symposium on Circuits and Systems (ISCAS), Daegu, Korea: IEEE, 2021), pp. 1–4 <https://doi.org/10.1109/ISCAS51556.2021.9401114>
6. Lu, Di, and Limin Yan, 'Face Detection and Recognition Algorithm in Digital Image Based on Computer Vision Sensor', ed. by HaibinLv, Journal of Sensors, 2021 (2021), 1–16 <https://doi.org/10.1155/2021/4796768>
7. M, Suman Menon, Anju Gerge, Aswathy N, and Jaimy James, 'Custom Face Recognition Using YOLO.V3', in 2021 3rd International Conference on Signal Processing and Communication (ICPSC) (presented at the 2021 3rd International Conference on Signal Processing and Communication (ICPSC), Coimbatore, India: IEEE, 2021), pp. 454–58 <https://doi.org/10.1109/ICSPSC51351.2021.9451684>
8. Alashbi, Abdulaziz Ali Saleh, Mohd Shahrizal Sunar, and Zieb Alqahtani, 'Context-Aware Face Detection for Occluded Faces', in 2020 6th International Conference on Interactive Digital Media (ICIDM) (presented at the 2020 6th International Conference on Interactive Digital Media (ICIDM), Bandung, Indonesia: IEEE, 2020), pp. 1–4 <https://doi.org/10.1109/ICIDM51048.2020.9339647>

9. Aswal, Vivek, Omkar Tupe, Shifa Shaikh, and Nadir N. Charniya, 'Single Camera Masked Face Identification', in 2020 19th IEEE International Conference on Machine Learning and Applications (ICMLA) (presented at the 2020 19th IEEE International Conference on Machine Learning and Applications (ICMLA), Miami, FL, USA: IEEE, 2020), pp. 57–60 <https://doi.org/10.1109/ICMLA51294.2020.00018>
10. Fawwaz, Faris, Burhanudin Dunggio, Putri Wulandari, IrmawanRahyadi, and Dwi Astharini, 'Vision Application of LabVIEW: IGUI for Face and Pattern Detection in Real Time', in 2020 International Conference on Information Management and Technology (ICIMTech) (presented at the 2020 International Conference on Information Management and Technology (ICIMTech), Bandung, Indonesia: IEEE, 2020), pp. 438–42 <https://doi.org/10.1109/ICIMTech50083.2020.9211282>
11. Guo, Qi, Zhihui Wang, Caixia Wang, and Dong Cui, 'Multi-Face Detection Algorithm Suitable for Video Surveillance', in 2020 International Conference on Computer Vision, Image and Deep Learning (CVIDL) (presented at the 2020 International Conference on Computer Vision, Image and Deep Learning (CVIDL), Chongqing, China: IEEE, 2020), pp. 27–33 <https://doi.org/10.1109/CVIDL51233.2020.00013>
12. Hou, Yao, and Mingrui Wang, 'Face Detection Method Based on Improved Convolutional Neural Network', in 2020 International Workshop on Electronic Communication and Artificial Intelligence (IWECAI) (presented at the 2020 International Workshop on Electronic Communication and Artificial Intelligence (IWECAI), Shanghai, China: IEEE, 2020), pp. 102–5 <https://doi.org/10.1109/IWECAI50956.2020.00028>
13. Hu, Xizhi, and Bingyu Huang, 'Face Detection Based on SSD and CamShift', in 2020 IEEE 9th Joint International Information Technology and Artificial Intelligence Conference (ITAIC) (presented at the 2020 IEEE 9th Joint International Information Technology and Artificial Intelligence Conference (ITAIC), Chongqing, China: IEEE, 2020), pp. 2324–28 <https://doi.org/10.1109/ITAIC49862.2020.9339094>
14. Kirana, Kartika Candra, Slamet Wibawanto, and Heru Wahyu Herwanto, 'Redundancy Reduction in Face Detection of Viola-Jones Using the Hill Climbing Algorithm', in 2020 4th International Conference on Vocational Education and Training (ICOVET) (presented at the 2020 4th International Conference on Vocational Education and Training (ICOVET), Malang, Indonesia: IEEE, 2020), pp. 139–43 <https://doi.org/10.1109/ICOVET50258.2020.9230349>
15. Nuruddin Pk, Abuzar Md., Xuwen Ding, and Tom Page, 'An Integrated Approach for Face Recognition Using Multi-Class SVM', in 2020 IEEE 5th International Conference on Cloud Computing and Big Data Analytics (ICCCBDA) (presented at the 2020 IEEE 5th International Conference on Cloud Computing and Big Data Analytics (ICCCBDA), Chengdu, China: IEEE, 2020), pp. 398–402 <https://doi.org/10.1109/ICCCBDA49378.2020.9095692>
16. Singh, Gurlove, and Amit Kumar Goel, 'Face Detection and Recognition System Using Digital Image Processing', in 2020 2nd International Conference on Innovative Mechanisms for Industry Applications (ICIMIA) (presented at the 2020 2nd International Conference on Innovative Mechanisms for Industry Applications (ICIMIA), Bangalore, India: IEEE, 2020), pp. 348–52 <https://doi.org/10.1109/ICIMIA48430.2020.9074838>
17. Lu, Wen-yao, and Ming Yang, 'Face Detection Based on Viola-Jones Algorithm Applying Composite Features', in 2019 International Conference on Robots & Intelligent System (ICRIS) (presented at the 2019 International Conference on Robots & Intelligent System (ICRIS), Haikou, China: IEEE, 2019), pp. 82–85 <https://doi.org/10.1109/ICRIS.2019.00029>
18. Nithin, P.B., Albert Francis, Ajai John Chemmanam, Bijoy A. Jose, and Jimson Mathew, 'Face Tracking Robot Testbed for Performance Assessment of Machine Learning Techniques', in 2019 7th International Conference on Smart Computing & Communications (ICSCC) (presented at the 2019 7th International Conference on Smart Computing & Communications (ICSCC), Sarawak, Malaysia, Malaysia: IEEE, 2019), pp. 1–5 <https://doi.org/10.1109/ICSCC.2019.8843628>

19. Peng, Bikang, and Anilkumar Kothalil Gopalakrishnan, 'A Face Detection Framework Based on Deep Cascaded Full Convolutional Neural Networks', in 2019 IEEE 4th International Conference on Computer and Communication Systems (ICCCS) (presented at the 2019 IEEE 4th International Conference on Computer and Communication Systems (ICCCS), Singapore: IEEE, 2019), pp. 47–51 <https://doi.org/10.1109/CCOMS.2019.8821692>
20. Putro, Muhamad Dwisnanto, Wahyono, and Kang-Hyun Jo, 'Multiple Layered Deep Learning Based Real-Time Face Detection', in 2019 5th International Conference on Science and Technology (ICST) (presented at the 2019 5th International Conference on Science and Technology (ICST), Yogyakarta, Indonesia: IEEE, 2019), pp. 1–5 <https://doi.org/10.1109/ICST47872.2019.9166172>
21. Reza Hashemi, Seyyed Mohammad, Hamid Hassanpour, and Ehsan Kozegar, 'An Overview of Face Detection Methods in Angular Positions', in 2019 5th Conference on Knowledge Based Engineering and Innovation (KBEI) (presented at the 2019 5th Conference on Knowledge Based Engineering and Innovation (KBEI), Tehran, Iran: IEEE, 2019), pp. 484–91 <https://doi.org/10.1109/KBEI.2019.8734955>
22. Wu, Tianpeng, Dong Liang, Jiaying Pan, and Shun'ichi Kaneko, 'Context-Anchors for Hybrid Resolution Face Detection', in 2019 IEEE International Conference on Image Processing (ICIP) (presented at the 2019 IEEE International Conference on Image Processing (ICIP), Taipei, Taiwan: IEEE, 2019), pp. 3297–3301 <https://doi.org/10.1109/ICIP.2019.8803548>
23. Xie, Rong, Qingyu Zhang, Enyuan Yang, and Qiang Zhu, 'A Method of Small Face Detection Based on CNN', in 2019 4th International Conference on Computational Intelligence and Applications (ICCI) (presented at the 2019 4th International Conference on Computational Intelligence and Applications (ICCI), Nanchang, China: IEEE, 2019), pp. 78–82 <https://doi.org/10.1109/ICCI.2019.00022>
24. Almadhor, Ahmad, 'Deep Learning Based Face Detection Algorithm for Mobile Applications', in TENCON 2018 - 2018 IEEE Region 10 Conference (presented at the TENCON 2018 - 2018 IEEE Region 10 Conference, Jeju, Korea (South): IEEE, 2018), pp. 1158–62 <https://doi.org/10.1109/TENCON.2018.8650093>
25. Barnouti, Nawaf Hazim, Mohanad Hazim Nsaif Al-Mayyahi, and Sinan Sameer Mahmood Al-Dabbagh, 'Real-Time Face Tracking and Recognition System Using Kanade-Lucas-Tomasi and Two-Dimensional Principal Component Analysis', in 2018 International Conference on Advanced Science and Engineering (ICOASE) (presented at the 2018 International Conference on Advanced Science and Engineering (ICOASE), Duhok: IEEE, 2018), pp. 24–29 <https://doi.org/10.1109/ICOASE.2018.8548818>
26. Chaudhari, Monali Nitin, Mrinal Deshmukh, Gayatri Ramrakhiani, and Rakshita Parvatikar, 'Face Detection Using Viola Jones Algorithm and Neural Networks', in 2018 Fourth International Conference on Computing Communication Control and Automation (ICCUBEA) (presented at the 2018 Fourth International Conference on Computing Communication Control and Automation (ICCUBEA), Pune, India: IEEE, 2018), pp. 1–6 <https://doi.org/10.1109/ICCUBEA.2018.8697768>
27. Dadkhah, Sajjad, Mario Koeppen, Somayeh Sadeghi, and Kaori Yoshida, 'Bad Ai: Investigating the Effect of Half-Toning Techniques on Unwanted Face Detection Systems', in 2018 9th IFIP International Conference on New Technologies, Mobility and Security (NTMS) (presented at the 2018 9th IFIP International Conference on New Technologies, Mobility and Security (NTMS), Paris: IEEE, 2018), pp. 1–5 <https://doi.org/10.1109/NTMS.2018.8328726>
28. Daryanavard, H., and A. Harifi, 'Implementing Face Detection System on UAV Using Raspberry Pi Platform', in Electrical Engineering (ICEE), Iranian Conference On (presented at the 2018 Iranian Conference on Electrical Engineering (ICEE), Mashhad: IEEE, 2018), pp. 1720–23 <https://doi.org/10.1109/ICEE.2018.8472476>
29. Guo, Zhuohao, Weixing Zhou, Luwei Xiao, Xiaohui Hu, Zehao Zhang, and Zhou Hong, 'Occlusion Face Detection Technology Based on Facial Physiology', in 2018 14th International Conference on Computational Intelligence and Security (CIS) (presented at the 2018 14th International Conference on Computational Intelligence and Security (CIS), Hangzhou, China: IEEE, 2018), pp. 106–9 <https://doi.org/10.1109/CIS2018.2018.00031>

30. Hao, Zeng, Qin Feng, and Lin Kaidong, 'An Optimized Face Detection Based on Adaboost Algorithm', in 2018 International Conference on Information Systems and Computer Aided Education (ICISCAE) (presented at the 2018 International Conference on Information Systems and Computer Aided Education (ICISCAE), Changchun, China: IEEE, 2018), pp. 375–78 <https://doi.org/10.1109/ICISCAE.2018.8666925>
31. Hsu, Heng-Wei, Tung-Yu Wu, Wing Hung Wong, and Chen-Yi Lee, 'Correlation-Based Face Detection for Recognizing Faces in Videos', in 2018 IEEE International Conference on Acoustics, Speech and Signal Processing (ICASSP) (presented at the ICASSP 2018 - 2018 IEEE International Conference on Acoustics, Speech and Signal Processing (ICASSP), Calgary, AB: IEEE, 2018), pp. 3101–5 <https://doi.org/10.1109/ICASSP.2018.8461485>
32. Huang, Deng-Yuan, Chao-Ho Chen, Tsong-Yi Chen, Jian-He Wu, and Chien-Chuan Ko, 'Real-Time Face Detection Using a Moving Camera', in 2018 32nd International Conference on Advanced Information Networking and Applications Workshops (WAINA) (presented at the 2018 32nd International Conference on Advanced Information Networking and Applications Workshops (WAINA), Krakow: IEEE, 2018), pp. 609–14 <https://doi.org/10.1109/WAINA.2018.00153>
33. Kopaczka, Marcin, Justus Schock, Jan Nestler, Kevin Kielholz, and Dorit Merhof, 'A Combined Modular System for Face Detection, Head Pose Estimation, Face Tracking and Emotion Recognition in Thermal Infrared Images', in 2018 IEEE International Conference on Imaging Systems and Techniques (IST) (presented at the 2018 IEEE International Conference on Imaging Systems and Techniques (IST), Krakow, Poland: IEEE, 2018), pp. 1–6 <https://doi.org/10.1109/IST.2018.8577124>
34. Kurnianggoro, Laksono, and Kang-Hyun Jo, 'Towards an Integrated Method of Detection and Description for Face Authentication System', in 2018 11th International Conference on Human System Interaction (HSI) (presented at the 2018 11th International Conference on Human System Interaction (HSI), Gdansk: IEEE, 2018), pp. 107–10 <https://doi.org/10.1109/HSI.2018.8430774>
35. Lee, Hai-Wu, Fan-Fan Peng, Xiu-Yun Lee, Hong-Nian Dai, and Ying Zhu, 'Research on Face Detection under Different Lighting', in 2018 IEEE International Conference on Applied System Invention (ICASI) (presented at the 2018 IEEE International Conference on Applied System Innovation (ICASI), Chiba: IEEE, 2018), pp. 1145–48 <https://doi.org/10.1109/ICASI.2018.8394486>
36. Mukai, Nobuhiko, Yulong Zhang, and Youngha Chang, 'Pet Face Detection', in 2018 Nicograph International (NicoInt) (presented at the 2018 Nicograph International (NicoInt), Tainan: IEEE, 2018), pp. 52–57 <https://doi.org/10.1109/NICOINT.2018.00018>
37. Pang, Lei, Yue Ming, and Li Chao, 'F-DR Net: Face Detection and Recognition in One Net', in 2018 14th IEEE International Conference on Signal Processing (ICSP) (presented at the 2018 14th IEEE International Conference on Signal Processing (ICSP), Beijing, China: IEEE, 2018), pp. 332–37 <https://doi.org/10.1109/ICSP.2018.8652436>