

Research Article

Date of Receive- 07th-May-2024

Date of Acceptance- 18th- may-2024

Date of Publication- 04th-June-2024

Ration Distribution with RFID and Mobile OTP Verification using Raspberry Pi

Shubham P. Deshpande^{1*}, Abhishek D. Biradar², Anish S. Butle³, Jai. Desai⁴

^{1,2,3}Students, Department of Electronics and Telecommunication Engineering, Sinhgad College of Engineering, Pune, Maharashtra, India.

⁴Professor, Department of Electronics and Telecommunication Engineering, Sinhgad College of Engineering, Pune, Maharashtra, India.

Author for Correspondence Email- spdeshpande162002@gmail.com

Abstract

The governmental provision of essential domestic commodities at subsidized rates to economically disadvantaged households in developing nations such as India serves as a crucial means of fulfilling basic needs. However, the current mechanism employed in ration shops relies heavily on manual processes for measuring commodities and maintaining transaction records, leading to various challenges including instances of diversion of food grains to the open market. The proposed project, titled " Ration Distribution System with RFID and Mobile OTP Using Raspberry Pi Pico 2040", " aims to address these issues through the implementation of an automated distribution method for authenticated beneficiaries. This system streamlines the process by integrating automatic dispensing machines and digital record-keeping functionalities. Upon logging into their accounts, beneficiaries can access information about available stock for the current month. To collect their allocated commodities, beneficiaries are required to present their RFID cards for authentication. Once authenticated, the system dispenses the predetermined quantity of

commodities designated for the household. This RFID-based system not only improves the efficiency of the distribution process but also enhances transparency and accountability by maintaining digital records of transactions. By leveraging RFID technology, the project aims to streamline the Public Distribution System, ensuring that essential commodities reach those in need in a timely and equitable manner.

Keywords: Public Distribution System (PDS), RFID, GSM modules, ration card, raspberry pi.

INTRODUCTION

The ration card is a crucial document for Indian citizens, facilitating the purchase of essential commodities at subsidized rates from government-run ration shops. However, the current distribution system faces challenges such as imprecise quantity measurement, manual labor, and long waiting times due to India's large population. We suggest an approach that uses GSM and RFID modules for data management and authentication in order to get around these problems[1].

Our system aims to revolutionize ration distribution by utilizing RFID technology embedded in smart ration cards. Each card contains beneficiary details and can be scanned at distribution shops equipped with RFID readers. Authentication is conducted through PIN or password, ensuring only valid beneficiaries receive their allocated goods. The system instantly deducts the quantity taken from the user's account and sends transaction details via SMS to their registered mobile number[2].

By integrating RFID and GSM modules, our proposed system enhances efficiency, accuracy, and transparency in the ration distribution process. Beneficiaries experience streamlined transactions with reduced waiting times, while the government ensures equitable distribution of essential goods to those in need[3]. This innovative approach modernizes India's ration distribution system, catering to the diverse needs of its vast population. RFID technology, which allows for the distinct identification and tracking of individual ration cards or recipients, is at the core of the updated ration distribution system[4]. Digitally encoded data, including beneficiary details and entitlements, is contained on RFID tags that are integrated into ration cards and biometric identification cards. These tags may be wirelessly scanned by RFID scanners, enabling quick and precise identification without the need for human verification[5-11].

1.1 EXISTING SYSTEM

Ration shops now use a system that requires human commodity measurement and transaction record management. The current system has numerous problems, like having to manually renew the ration card each year and diverting food grains to the open market. Inconsistencies in store opening times and false claims of food grain shortages are further problems. Therefore, implementing an embedded system for the same is preferable.

S.No	Title	Year	Author	Information
Paper 1	Automated Ration Distribution System Using Rfid, Gsm, Otp Based Real Time Ration Stock Monitoring” (IRJMETS),India.	2023	Swaroopraj Panzade, Gouri Wanode, Pratik Bangadkar, Sarthak Raut, H.P. Rewatkar	<ul style="list-style-type: none"> ▪ Electronic components including the Arduino mega 2560 microcontroller. ▪ The system's real-time monitoring capabilities have made it possible to quickly identify and resolve any issues that arise during the distribution process.
Paper 2	“Automatic Ration Vending Machine using RFID and GSM Technology(Bio-metric Authentication)” (IRJMETS),India.	2022	Shrikrishna Huilgol, Sivapuram Ramarohith, Shrimidhi Hegde, Priyanka Shisanalli, Prof. Varsha Jadhav	<ul style="list-style-type: none"> ▪ Arduino Mega 2560 - Used as a microcontroller for the project. ▪ Servo motor - For dispensing solid materials. ▪ Even after taking specific amount of ration card not blocked.

Paper 3	“A Step Towards Smart System of Ration Card using Biometric and RFID” (IRJMETS), India.	2021	Dr. Sanjay R. Sange , Dr. Hemant Palivela, Mukta Awate, Namrata Jamdar, Shivani Nanavare, Ranjana Margale	<ul style="list-style-type: none"> ▪ The Arduino Mega 2560 board is used as the main processing unit of the smart ration card system. ▪ The Smart ration card system proposed in this paper uses RFID technology along with biometric. ▪ Due to the Fingerprint biometric extra security is added.
Paper 4	“Advanced Automatic Ration Material Distribution System.” (IEEE conference WPNC&GSW) ,Delhi, DL, India.	2018	S.R.Kurkute P.P.Chaudhari ,B. D. Deore, KishoriKavare ,Priyanka Musale, DaminiBhoye.	<ul style="list-style-type: none"> ▪ The proposed system is based on an ATmega328 which is used for user authentication, validation and notification. ▪ Even after taking specific amount of ration card not blocked.

1.2 PROPOSED SYSTEM

This device functions by displaying the RFID tag that the government sent to the customer; if an RFID reader detects the tag, the customer is permitted to go to the next authentication step. Following successful verification, the customer can choose the kind and amount of the ration; the product outlet will then send the chosen item in the necessary quantity to the customer. The government's database is updated with the details of purchases, and messages about goods purchases are texted to consumers' mobile devices.

2. DESIGN AND DEVELOPMENT

2.1 OBJECTIVES

Efforts to overhaul the ration distribution system aim at multiple objectives. Firstly, there's a crucial focus on combating fraud and corruption within the system, ensuring that resources reach those truly in need. This ties closely with the second goal of guaranteeing that only eligible beneficiaries receive ration, enhancing the system's fairness and efficacy.

Additionally, streamlining processes to reduce manual effort is a priority, paving the way for a more efficient and transparent distribution mechanism. Simultaneously, enhancing the accountability of ration shop owners is essential in maintaining integrity and trust in the system. Moreover, efforts are directed towards creating a more user-friendly experience for ration beneficiaries, prioritizing convenience, and accessibility in accessing essential supplies. Through these concerted actions, the ration distribution system strives to fulfill its core mandate while adapting to modern demands and challenges.

Mobile One-Time Password Verification: Safe and Easy Authentication

Apart from RFID, the distribution process is further secured and authenticated using mobile One-Time Password (OTP) verification. In order to get unique OTPs by SMS or mobile apps during each distribution cycle, beneficiaries must register their mobile numbers with the ration distribution system.

Beneficiaries scan their ration cards or biometric IDs with an RFID reader when picking up their rations, then input the generated OTP into a portable device or Raspberry Pi terminal. In order to reduce the possibility of impersonation or illegal access, this two-factor authentication procedure verifies that the individual picking up the ration is, in fact, the intended beneficiary.

2.2 TOOLS AND TECHNOLOGIES

Hardware Components

- 1 **EM-18 RFID Reader:** This block reads the RFID tag of the beneficiary to identify them.
- 2 **GSM SIM Module:** This block is used to send OTP to the beneficiary's mobile number and receive SMS alerts.

3 **Relay:** This relay controls the power supply to the motor.

Raspberry Pi Pico 2040: This microcontroller controls the entire system and processes the data. A credit card-sized computer known for its affordability, adaptability, and simplicity of use, the Raspberry Pi is essential to the deployment of RFID and mobile OTP authentication in ration distribution systems. The Raspberry Pi is a computational hub that integrates and orchestrates the many components of the distribution system. It is equipped with GPIO (General-Purpose Input/Output) pins and can run multiple operating systems, including Linux-based versions. For monitoring helpful data, confirming transactions, and producing real-time reporting, developers can design simple and user-friendly interfaces using RFID readers, GSM modules for mobile connectivity, and custom software programmes. Because of its small size and low electrical consumption, the Raspberry Pi is a great choice for adoption in distant or resource-constrained areas where conventional computing infrastructure could be too expensive or unfeasible.

4 **L293D Motor Driver:** This block drives the motor to dispense the ration.

5 **16x2 LCD Display:** This display shows instructions and information to the beneficiary.

6 **4x3 Keyboard:** This keyboard is used by the beneficiary to enter the OTP.

Software Components

1. **Arduino IDE** - As an IDE for Arduino Mega code.
2. **C/C++** - Programming language.
3. **Windows OS** - W7 +

METHODOLOGY

Verification of the RFID card: After the user flashes the card to the scanner, the system checks to see if it is valid and then moves on to pin or fingerprint authentication.

Pin Verification: Using a 4*4 keypad, the user will input a four-digit pin. The pin will then be compared to the appropriate card pin number; if they match, the pin confirms the user and moves on to the next stage; if not, the procedure will end.

Ration Dispense: The beneficiary is given a list of the goods that are in the FPS following the RFID card's verification. The recipient is required to select the items from a list that they wish to purchase. The total amount of the commodities he wishes to purchase will be displayed to him by the system. Beneficiaries receive the merchandise after he or she verifies the goods.

SMS Sending: After the ration is dispensed from the outlet, send the user an SMS using GSM technology.

Update Stock: The system will be updated with the new balance for that specific month after the ration is purchased.

BLOCK DIAGRAM: Block Diagram of proposed system is shown in Figure 1.

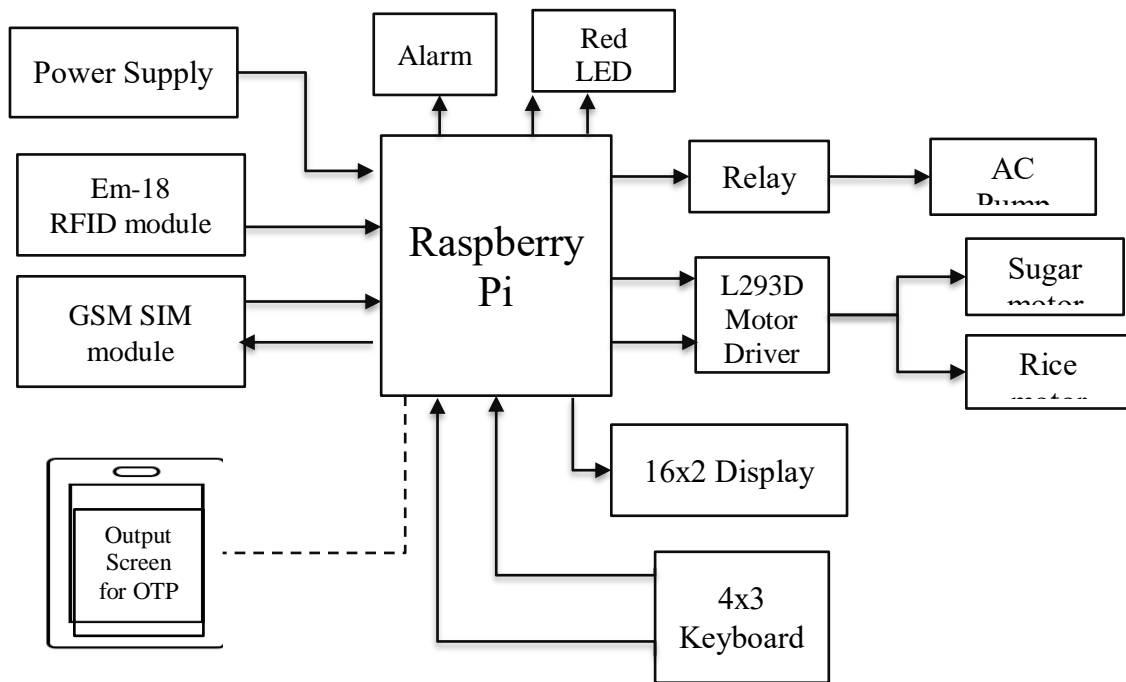
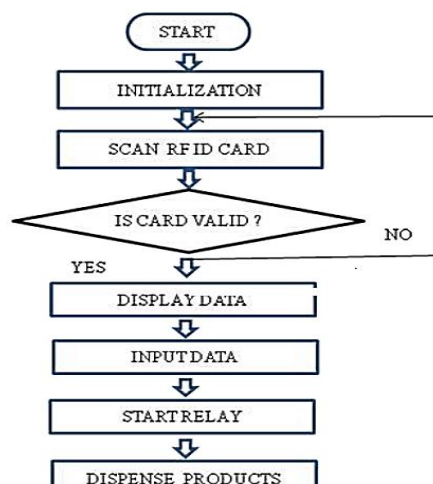

Figure 1 Block Diagram of proposed system

FLOWCHART: Flowchart of proposed system is shown in Figure 2. Overview of Developed Model is shown in Figure 3.



2.3 RESULTS

Figure2. Flowchart of proposed system

Precision in Quantity: The RFID technology we incorporated ensures that the quantity of goods distributed to beneficiaries is measured with utmost precision. This has significantly reduced errors in ration allocation, ensuring a fair and accurate distribution process.

Reduced Physical Work and Processing Time: Our new RFID-based system has drastically cut down the manual work involved in processing ration transactions.

Minimized Waiting Time: Waiting times at ration distribution centers have seen a remarkable decrease due to the implementation of RFID technology. Shorter lines and faster processing for beneficiaries result in a more effective and user-friendly process overall.

Precision in Quantity: The RFID technology ensures a precise measurement of the quantity of goods distributed to beneficiaries, reducing discrepancies in ration allocation. Results are shown in Figure 4. Time Breakdown by Task: Traditional vs. RFID/GSM System is shown in Table 1.

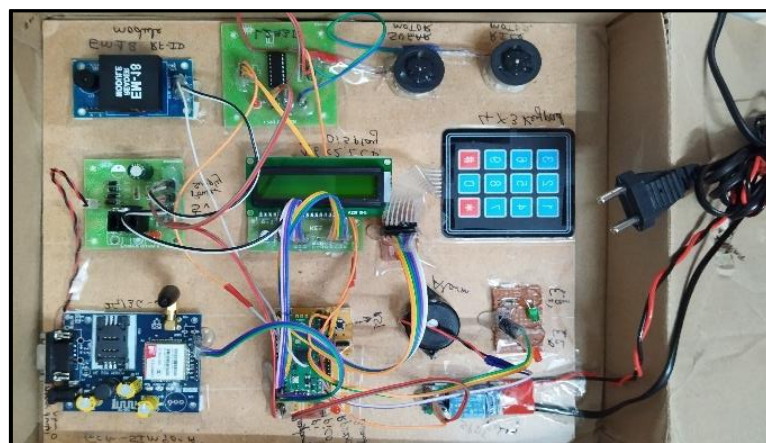

Figure 3. Overview of Developed Model

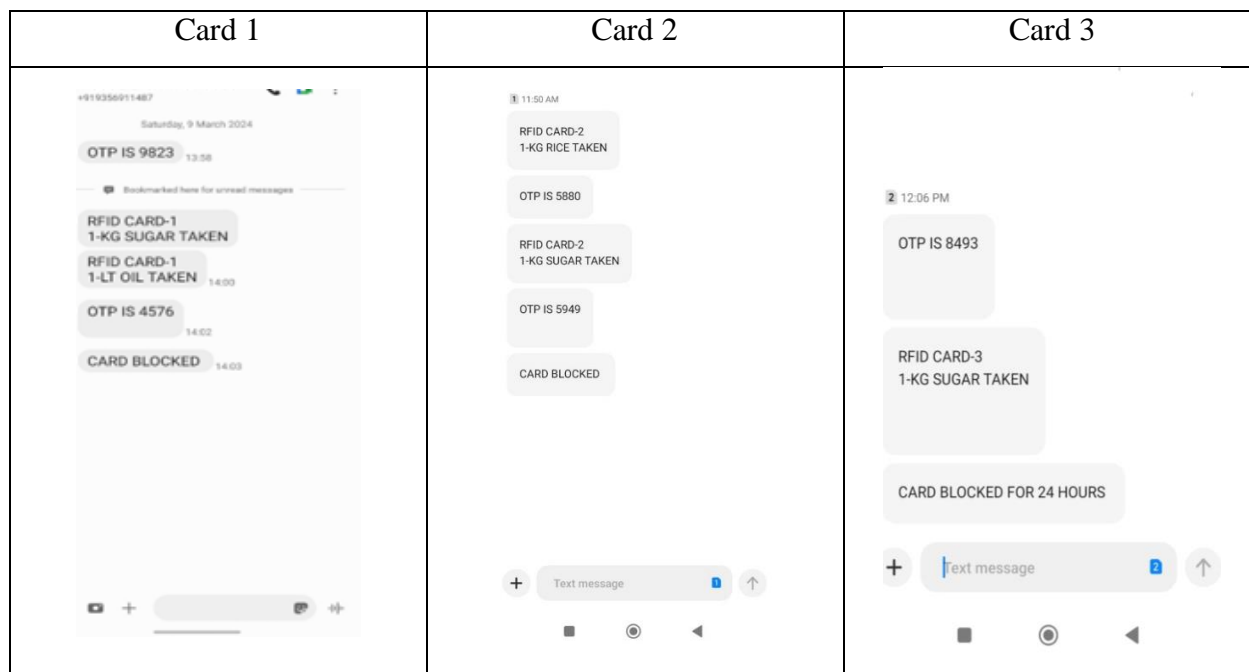

Figure 4. Output Result

Feature	Traditional System (Minutes)	RFID/GSM System (Minutes)
Ration card verification	2-5	1
Weighing and dispensing	3-7	1-2
Record keeping	1-2	0.5
Total Distribution Time	6-14	2.5-3.5

Table 1. Time Breakdown by Task: Traditional vs. RFID/GSM System

3. CONCLUSION

The implementation of the Ration Distribution System with Mobile OTP and RFID using Raspberry Pi Pico 2040 marks a significant leap forward in revolutionizing traditional ration distribution processes. This innovative system addresses multiple challenges associated with fraud, inefficiency, and lack of transparency in the existing system. The amalgamation of various components, from the EM-18 RFID reader to the GSM SIM module, showcases a comprehensive approach to modernizing the distribution process. The Raspberry Pi Pico 2040, serving as the

central microcontroller, orchestrates the seamless integration of these components, ensuring efficient data processing and system control.

The improved security measures are one of the project's main accomplishments. The EM-18 RFID reader authenticates beneficiaries, preventing unauthorized access and potential fraud. An additional degree of security is provided by the red LED and alarm system, which provide real-time alerts.

The use of OTP via the GSM SIM module ensures a secure and personalized interaction with beneficiaries, reducing the risk of misuse.

In conclusion, the Ration Distribution System with Mobile OTP and RFID using Raspberry Pi Pico 2040 is not just a technological upgrade; it represents a transformative approach to public welfare. By addressing key issues in the existing system, the project sets a benchmark for future innovations in ensuring fair, efficient, and secure distribution of essential commodities to those who need them most.

ADVANTAGES

1. **Enhanced Security:** Ensures only authorized individuals can access ration supplies, reducing the risk of fraud and theft.
2. **Real-time Tracking:** Enables accurate monitoring of ration distribution, improving accountability and transparency.
3. **Improved Efficiency:** Streamlines the verification process, reducing wait times and enhancing overall distribution efficiency.
4. **Accessibility:** Mobile OTP verification allows for convenient authentication, even in remote or offline areas with limited connectivity.
5. **Cost-effectiveness:** Utilizing Raspberry Pi Pico 2040 offers a low-cost solution compared to proprietary hardware, making it more accessible for implementation in resource-constrained environments.

REFERENCES

- [1] "Automated Ration Distribution System Using Rfid, Gsm, Otpbased Real Time Ration Stock Monitoring", Swaroopraj Panzade ,Gouri Wanode-April-2023.

- [2] "A Step Towards Smart System of Ration Card using Biometric and RFID", Dr.Sanjay R. Sange, Dr.Hemant Palivela, (IRJMETS), India, 2023.
- [3] "Advanced Automatic Ration Material Distribution System", Delhi, DL, India. S.R.Kurkute P.P.Chaudhari . 2022.
- [4] Mast. Amarsinh Desai, "Automatic Ration Vending Machine Using RFID for Indian Ration System, Research Gate, <https://www.researchgate.net/publication/366216377>, December 2022.
- [5] Rutuja Crorapwar, Anufa Bhargude, Smita Craikwad, Sneha Zagade, Prof.G.S. Bhange "Smart Automatic Rationing System", in International Journal Of Innovative Research In Science, Engineering, and Technology, Vol. 8, Issue 1, ISSN 2319-8753, pp. 71-74, January 2019.
- [6] Reshma Arote, Komal Nawak, Monika Shide, Prof.P.A Bansode, Prof, V.B Bhamare "Smart Rationing System Using Aadhar Card", in International Journal of Innovative Research in Computer and Communication Engineering, Vol. 6, Issue 3, ISSN 2320-9801, pp. 1949-1954, March 2018.
- [7] M. Pallikonda Rajesekaran, R. Arthi, D. Balaji and P. Daniel, "Automatic smart ration distribution system for prevention of civil supplies hoarding in India", Advanced Computing and Communication Systems,2017 4th International Conference on 6-7, Jan 2017.
- [8] Rudrawar SK, Phad K, Durugkar P. IoT Enabled Secured Card Less Ration Distribution System. InTechno-Societal 2020: Proceedings of the 3rd International Conference on Advanced Technologies for Societal Applications—Volume 1 2021 May 20 (pp. 477-487). Cham: Springer International Publishing.
- [9] Avinash NJ, NS KR, Moorthy R, Shenoy A, Chetan R, Bhat S. Android App and RFID Based Smart Ration Distribution System. In2021 IEEE International Conference on Mobile Networks and Wireless Communications (ICMNWC) 2021 Dec 3 (pp. 1-5). IEEE.
- [10] Machikuri SK, Valluri BK, Bathula J, Pasha S, Zabibah RS, Anandhi RJ, Singh N, Kalra R. Advanced interdisciplinary techniques for revolutionized government ration dispensing system using IoT. InE3S Web of Conferences 2024 (Vol. 507, p. 01028). EDP Sciences.
- [11] Nair A, Shaikh Mohammad BN. A Proposed Model for Smart Public Distribution System of Ration Commodities to Indian Citizens using an IoT based Design. InProceedings of the 4th International Conference on Advances in Science & Technology (ICAST2021) 2021 May 7.

Journal of Microcontroller Engineering and Applications (JOMEA)
ISSN: 2455-197X
Volume-11
Issue-1
Year-2024