

## Smart Safety: Evaluating INVIGUARD as an Innovative Wearable Device for Head Protection

Supriya Nayak\*, Deekshitha Arasa, Suraj Mukherjee,  
Sureshkumar Kaluram Choudhary, Syed Zohair Ammar

### Abstract

*This study details INVIGUARD, an innovative head protection wearable device designed to prevent falls and accidental collisions for the special people. The device is neck-worn and utilizes a unique structure in the form of a honeycomb which when a threat is recognized will expand in volume to form a protective shield around the head whilst in normal usage is small in size; when the danger is no longer perceived. Such a construction of honeycombs guarantees reliability and stability and at the same time optimizes the effects of forces on the structure. A multifunctional device integrating several sensors: accelerometer detection, gyroscope, and pulse and temperature sensors together with GPS and GSM modules activates the functions of INVIGUARD. The elements listed work together to monitor the user's environment and the user himself in order to detect any potential hazards. INVIGUARD's sensors detect, impact and trigger the device to deploy as an additional cushion for the head when a potential safety threat is predicted and imminent, thereby reducing possible harm. Simultaneously, INVIGUARD automatically interfaces with a proprietary web portal to alert caregivers and provide them with a real-time status report of the surroundings of the user in distress. This is the first wearable technology that incorporates protection within its own design while simultaneously initiating automated communications (alarms) with caregivers based on critically predicted imminent future problems.*

**Keywords:** Inviguard, wearable device, honeycomb, protective shield, gyroscope, GPS and GSM

### INTRODUCTION

The application of assistive technologies to improve safety and quality of life for people with special needs has been an emerging area in the past decade [1]. Few devices give immediate physical protection in situations literally posing a risk to damage, most others provide monitoring and warning systems. Physically challenged people, especially, are prone to head injury as they may be more vulnerable to accidental falls or collisions than normal subjects do [2]. Our work therefore proposes INVIGUARD as an innovative wearable device for real-time protective intervention specializing in head protection.

INVIGUARD's unique, collapsible honeycomb structure is a combination of strength, flexibility and impact resistance for efficient protection about the region of the head. It is designed to be small and handy so it can be easily worn around the neck [3]. It will stay hidden during normal course of operation with a sudden deployment only upon detecting a threat. The device incorporates servo motor, GPS and GSM modules, ESP32 microprocessor and an array of powerful sensors including temperature sensor, pulse sensor, gyroscope and accelerometer sensors that constantly monitor the physiological signals of the user as well as the immediate environment for any

#### \*Author for Correspondence

Supriya Nayak  
E-mail: nsupriya2912@gmail.com

Student, Department of Electrical & Electronics Engineering,  
Dayananda Sagar College of Engineering, Bengaluru,  
Karnataka, India

Received Date: January 15, 2025  
Accepted Date: January 20, 2025  
Published Date: February 08, 2025

**Citation:** Supriya Nayak, Deekshitha Arasa, Suraj Mukherjee, Sureshkumar Kaluram Choudhary, Syed Zohair Ammar. Smart Safety: Evaluating INVIGUARD as an Innovative Wearable Device for Head Protection. Journal of Telecommunication, Switching Systems and Networks. 2025; 12(1): 15–26p.

---

sudden or dangerous change [4]. INVIGUARD will deploy when threat is detected. That is, it will expand itself over the head and meanwhile a real-time alert of alarm is also sent to an online platform where the caretakers get notified about the user's location and health condition. INVIGUARD is developed to mitigate the probability and intensity of head injuries for special needs' people. This device integrates automation, monitoring, notification, and physical protection features in a unique way. In this study, designing, operation and testing of INVIGUARD are discussed with main focuses on how it could fill existing gap in wearable safety technology for the vulnerable.

## LITERATURE REVIEW

The paper by Subramaniam *et al.* explores wearable sensors, like gyroscopes and accelerometers for fall risk assessment in the elderly and disabled [1]. It discusses challenges such as sensor placement and power management and highlights the use of machine learning to improve accuracy, with recommendations for future research.

The paper by Ferreira *et al.* reviews wearable sensors for fall risk assessment in older adults, focusing on accelerometers and gyroscopes [2]. It discusses data analysis methods, including machine learning, and highlights challenges like accuracy and comfort, calling for further research to improve fall prevention systems.

The paper by Alinia and Yuce reviews wearable fall detection systems for elderly individuals, focusing on sensors like accelerometers and gyroscopes [3]. It discusses detection algorithms, system designs, and challenges such as accuracy and false alarms.

The study by Nugent *et al.* suggests improvements to enhance reliability and user acceptance [4].

The paper by Klenk *et al.* examines accelerometer-based wearable devices for fall detection, focusing on motion analysis algorithms to improve accuracy and reduce false alarms. It addresses challenges in sensor reliability for effective health monitoring [5]. The paper reviews sensor-based systems for early fall detection in older adults, examining sensor types and data techniques to improve safety. It highlights challenges in accuracy and practical use.

The paper by Chen *et al.* explores automated fall detection using wearable technology, focusing on algorithms and sensors to accurately detect falls and enhance user safety [6].

The paper by Patil *et al.* presents an origami-inspired impact absorption design for safety helmets, aimed at improving protection. It explores applications in child safety and real-time biomedical monitoring using temperature sensors and IoT [7].

The paper by Srinivasan *et al.* presents an IoT-based child safety system using machine learning. It integrates sensors like temperature, GPS, and GSM to monitor a child's safety, using a Decision Tree Classifier for real-time risk assessment and alerts via GSM [8].

The paper by Moodbidri and Shahnasser presents a wearable device for child safety, using sensors like GPS to monitor the child's movements and environment. It provides real-time alerts to guardians in case of potential danger, enhancing child protection [9].

The paper by Nitishree reviews IoT-based GPS devices for enhancing the safety of children and women, focusing on real-time location tracking and emergency alerts to improve personal security [10].

## PROBLEM FORMULATION AND PROPOSED SOLUTION

### Problem Formulation

People with special needs are more vulnerable to brain injury due to accidental falls or collisions, which often occur without prompt medical treatment. This vulnerable group is at higher risk for injury

because current wearable safety solutions prioritize alarms over direct physical protection. By providing dual-purpose wearable devices with active body protection and real-time diagnostics and alarms, INVIGUARD seeks to close this gap. INVIGUARD, a small device worn around the neck with a pressable honeycomb, uses an integrated system of ESP32 microprocessor-controlled sensors (accelerometer, gyroscope, pulse, temperature) to respond to hazard detection and a communication module (GPS, GSM). This technology protects the head in case of emergency notifying caregivers through an online portal meets important safety needs for people with disabilities.

### **Proposed Solution**

INVIGUARD is a small wearable safety device that acts as a real-time alarm system and provides physical protection for individuals with disabilities. Good point protection is essential for critical items in this area:

#### ***Honeycomb-Shaped Protective Gear***

This neck-worn device, crafted from a durable honeycomb-like material, may experience rapid expansion, leading to unintended dripping [2].

#### ***Smart Sensor Integration***

Accelerometer, gyroscope, pulse, and temperature sensors are among the many sensors used by INVIGUARD to continuously monitor the environment and the user's physical condition. These sensors are important for special or multiple speeds making power control complex.

#### ***Automatic Deployment Mechanism***

The ESP32 microcontroller senses a threat and activates the servomotor, causing the deployment mechanism to extend the honeycomb system around the crown. Losses are reduced due to the immediate creation of physical defenses.

#### ***Real-Time Monitoring and Alerting***

INVIGUARD uses its GPS and GSM capabilities to assist in emergency response by notifying caregivers of a suspension and providing real-time location and status information provided online to the department in question. Thanks to this network, the security status of the individual is constantly tracked.

## **METHODOLOGY BLOCK DIAGRAM**

The approach to the INVIGUARD system is based on the integration of multiple sensors and control systems to provide practical safety equipment for people with special needs as shown in Figure 1. The device includes the following important modules:

### **Sensor Integration**

Multiple sensors such as accelerometer, gyroscope, temperature sensor and pulse sensor constantly monitor the user's health and surroundings. These sensors indicate any abnormal or dangerous conditions.

### **ARM Controller and Safety Device**

The ARM controller analyzes the sensor input signals and acts as a central processing unit. The controller detects a potential hazard and determines the protection to be implemented by turning on the protection switch.

### **Motor Control and Helmet Mechanism**

The helmet mechanism, which is a honeycomb-like compressible structure designed to protect the head is activated by the motor control unit when it receives an activation signal and this structure swells quickly just for physical security.

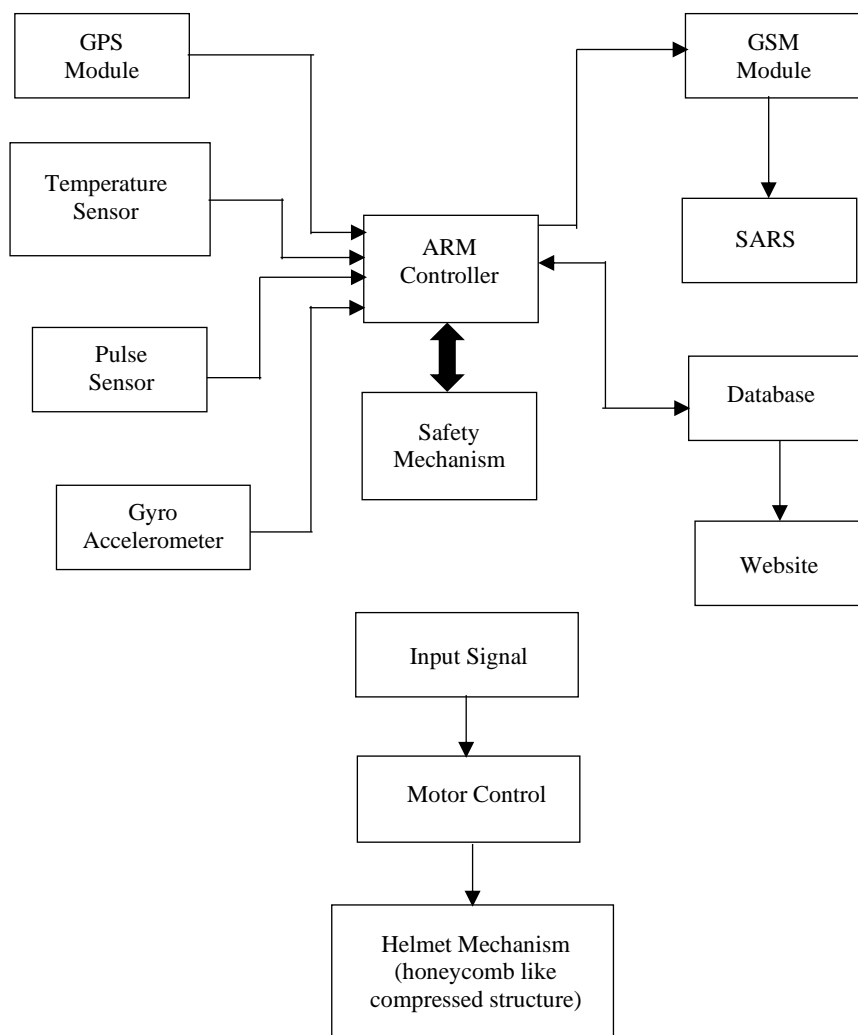

**Figure 1.** Block diagram of the INVIGUARD.

### Communication Module

The device includes a GSM module for emergency communication and a GPS module for real-time location. The system notifies responders and caregivers of location and status, by sending SMS alert messages in the event of an incident, and updating specific databases and websites. This approach combines real-time analysis, automatic programming and instantaneous alarm capabilities for improved safety and faster response.

### CIRCUIT DIAGRAM

Wearable safety device INVIGUARD, as can be seen from circuit diagram, its main processing unit is an ESP32 microcontroller (U2), as shown in Figure 2. For alerting reasons, this system is made to interface with external modules like GPS and GSM, control servo motors, and gather data from a variety of sensors. The parts and connections of the circuit are broken down as follows:

### Section on Power Supply

The circuit is powered by 7.4 V DC from a lithium-ion battery pack (BT1). For optimum battery performance, the TP5100 Battery Management System (BMS) is used, which protects against short circuit, overcharging and over discharging. Two LM2596S buck converters (U5 and U6) are used to reduce the battery voltage to 5 V. These transformers contain robust and efficient power for the ESP32 microprocessor, servos, sensors, and other system components.

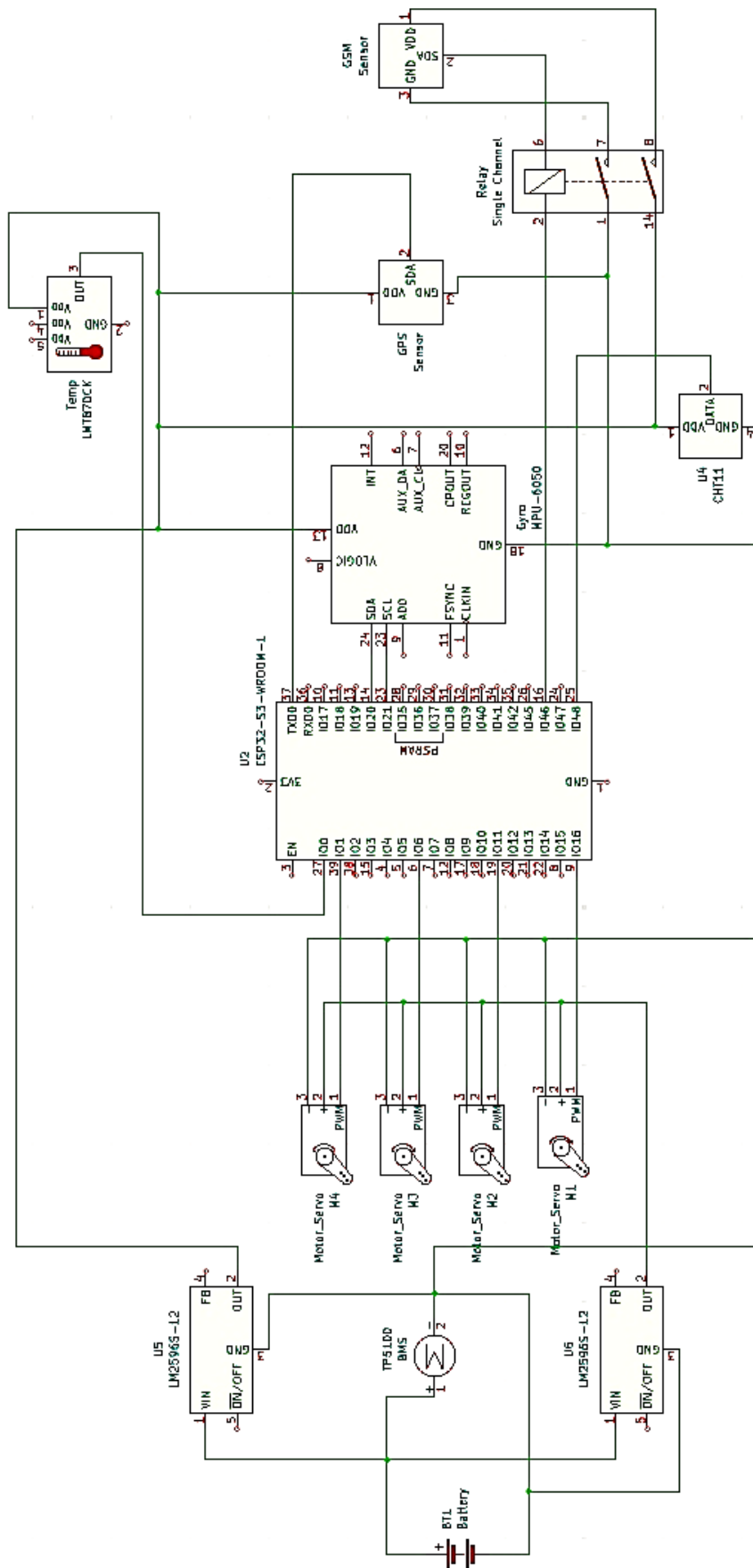

Figure 2. Circuit Diagram of the INVIGUARD.

---

## Microcontroller

At the center of the circuit, a high-performance microcontroller ESP32-S3 WROOM-1 controls all inputs and outputs. The ESP32 handles information from several sensors, manages the motor servos and connects to other devices via Bluetooth or Wi-Fi. Its adaptability and precise timing capabilities facilitate real-time monitoring and management of propulsion activities essential for this task.

## Integration of Sensors

The circuit has multiple sensors to track different characteristics. The MPU-6050 accelerometer and gyroscope measure movement and velocity. It uses I2C communication to connect to the ESP32. The LMT87DCK temperature sensor monitors the temperature of the body or environment and transmits data to the microcontroller, which processes the signals for motor control.

## Servo Management

The ESP32 is linked to the four motor servos (M1 through M4) by PWM (pulse width modulation) pins. The tender structure that surrounds the position, is actuated by these servos. The ESP32 alerts the servos to a fall or emergencies, which prompts them to promptly and precisely activate and use the safety device.

## Faculty Relay

To enhance the circuit's force dispersion level, further check the amp mono electrical relay faculty is incorporated. When not in use, the relay is used to selectively power specific parts like the GPS or GSM module in order to save energy.

## Sensors

The system too includes amp cht11 Findor, which potentially measures environmental factors such as arsenic humidness or temperature. This sensor adds another layer of information to the system, helping to watch conditions that might affect the operator's safety. The information from this finder is refined from the esp32 conducive to the overall safety monitoring unit.

## Workflow for Operations

In order to force the ESP32 and its peripherals, the twist top draws force from the assault, regulated by charge converters. The ESP32 receives information from the MPU-6050's continuous motion, watching for in-the-moment analysis. Upon detecting a fall or impact, the ESP32 uses the GSM and GPS modules to pass caregivers set information and alerts, while also activating of the servos to use the tender mechanics.

## PCB DESIGN

The INVIGUARD's PCB layout of the project specifies the component layout and configuration of the wearable safety device as shown in Figure 3.

Below is a summary of the main components and their location:

1. The ESP32-S3-WROOM-1 (U2) is the central processor unit that controls communications and machine operations. The device can send data and connect to the INVIGUARD website thanks to built-in Wi-Fi and Bluetooth.
2. Wireless connectivity, necessary for real-time data transfer, is provided by an antenna, located on the ESP32 module.
3. GPS Module (GPS1): This module provides device location tracking capabilities, enabling real-time location data generation. GPS data can be used to track someone in an emergency or fall.
4. Cellular connectivity is provided by a GSM module (GSM1), which allows the device to make instant calls or send SMS. It guarantees connectivity even in the absence of Wi-Fi.

5. MPU-6050 (U3): This accelerometer and gyroscope sensor helps detect abnormal movement or fall. Thanks to the MPU 6050's critical role in motion monitoring and functional analysis, the device can accurately detect falls.
6. LMT87/DCK Temperature Sensor: As part of the safety system, this sensor can be used to measure the ambient temperature or user position.
7. Temperature and humidity are measured using CHT11 (Humidity and Temperature Sensor) which helps to target the area.

## WORKING AND WORKING MODEL

When integrated, the INVIGUARD system offers emergency signaling, protective positioning, and monitoring using the hardware with the support of software solutions as shown in Figure 4. The following is a full working technique based on the flow diagram:

### Hardware Elements

#### *ESP32 Initialization*

The ESP32 microcontroller which is a control unit for collecting and processing data of several sensors is switched on at the beginning of the process.

#### *Sensor Initialization*

To observe critical rates, the system starts various sensors when the ESP32 is switched on. These sensors consist of:

1. The temperature sensor: measures the user's body temperature.
2. Heart Rate Sensor: This device measures blood pulse and gives other important parameters of health state.
3. Accelerometer: Senses and detects rare motion, for instance, contact with objects or a fall.

#### *Data Gathering and Transmission*

On each of them, there is continuous real-time reading and data transmission to the ESP32 by every sensor. Once this information is compiled, the microcontroller sends it using an Application Programming Interface to a server.



Figure 3. PCB design.

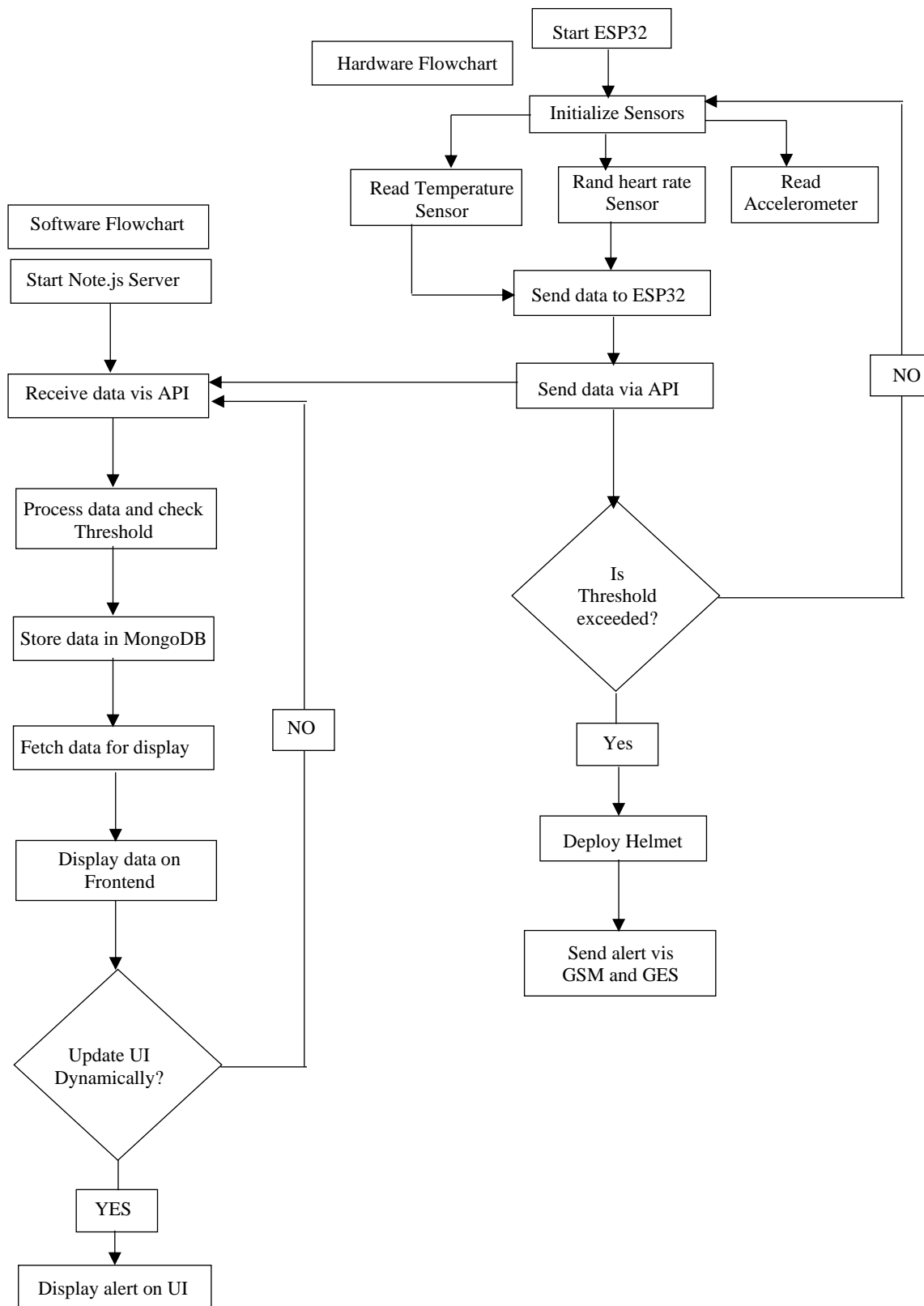

**Figure 4.** Flow chart of the working mechanism of INVIGUARD.

**Threshold Analysis**

Once the data has been received, the system identifies if any of the parameters that are being monitored exceed the certain specified limits which in fact mean that there might be a potentially

dangerous situation for the user. Its output activates the safety procedures of this threshold check. If the threshold is not crossed, the helmet mechanism is not enabled, and the system continues to observe.

### ***Safety Mechanism Deployment***

Finally, the ESP32 signals the motor control to switch on the helmet mechanism when a threshold is reached. The helmet has honeycomb-like design that enables it to expand when worn on the head in order to provide specific physical protection.

### ***Emergency Alert Transmission***

For instance, to send an alert message, the system uses both GPS and GSM modules at the same time. In the alert, specific location and state of the user is provided thus enabling the emergency personnel or the carers to be well informed.

### **Software Elements**

#### ***Initialization of the Node.js Server***

On a software side, Node.js server is enabled in order to manage the flow of data between backend system and the hardware. This communication is done through an API over the internet where data is sent from the ESP32 to the server.

#### ***Threshold Verification and Data Processing***

Server checks the established threshold levels and analyses the incoming data. This procedure of verification ensures that action is needed in the emergency situation and, at the same time, guarantees its proper reaction.

#### ***Data Storage in MongoDB***

The user's health parameters undergo change, and if any incident occurs, all the data is stored in the MongoDB database, initiating a log of the user incidents. Such storage is helpful in risk management and continuing care, as historical analysis is possible after data collection.

#### ***User Interface and Real-Time Display***

Finally, the frontend interface of the system displays the data which is in the system to the users in a more convenient format for use. The status of the user changes in real time, and the caregivers have the opportunity to look at the alerts or precautions made by the system.

#### ***Dynamic User Interface Updates***

One factor is that the user interface changes to suit the changes that occur in the user's environment. The UI of the webapp will change as soon as there are any changes in the status of an alarm so that caregivers will be informed at once.

#### ***Alert Display***

For caregivers to be informed that a certain limit has been attained, an alarm is provided on the user interface. Although called a visual alert, the message serves as another form of alert apart from the GPS and SMS alerts.

### **DESIGNING OF INVIGUARD**

The design of the INVIGUARD device carefully incorporates synthetic honeycomb to improve strength and shock resistance while retaining its lightweight character [5]. This was carefully achieved using sophisticated 3D modelling tools as shown in Figure 5. This system was improved for durability and efficiency. Once the digital design was completed, the design was transferred for 3D printing and a physical prototype was created. We were able to use this 3D-printed model to verify the effectiveness and efficiency of the design in a realistic scenario, reinforcing the potential of INVIGUARD as a dependable security solution for individuals with disabilities.

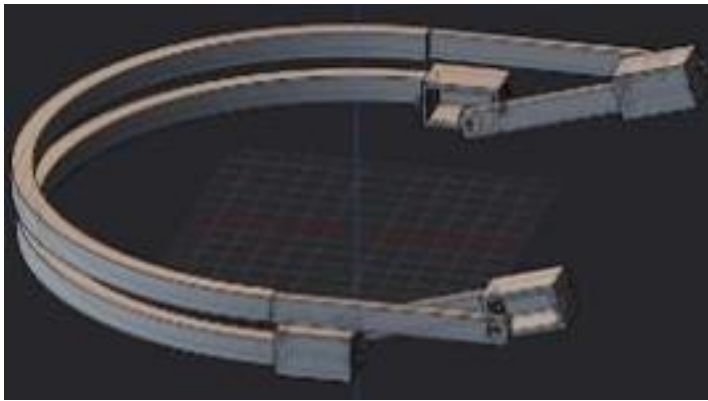

**Figure 5.** Designing of INVIGUARD.

### **Battery Optimization**

The INVIGUARD project's optimization operating system is designed to ensure safe charging, energy efficiency, and reliable battery monitoring. Step by step detail is explained below:

#### ***Battery pack***

A 7.4 V Li-ion battery pack powers the system. By passing this power through a buck converter, which steps it down to a stable 6 V output, an optimum effective voltage level is supplied to device components.

#### ***Charging***

An 8.4 V output 2S charger can be used to safely recharge the battery pack. This system extends battery life and protects against overheating and other battery-related problems by ensuring that it charges within safe limits.

#### ***Battery Monitoring***

A battery management system (BMS) is included in the circuit to prevent overcharging and over draining of the battery pack. It ensures continuous operation, providing real-time data on battery health, and charge level.

#### ***Power Switching***

Relay modules are used to regulate power to special components such as servos or sensors as needed to conserve energy. This improves battery management and extends the life of the device by allowing the system to turn off features when they are not in use. Using Li-ion batteries, this process provides a reliable, rechargeable energy source with optimized energy efficiency, energy conversion flexibility, and battery management.

## **RESULTS**

1. Successful deployment of helmet-like structure is shown in Figure 6 [8]. Under fall conditions, the helmet-like construction of the device was consistently applied, covering effective head area. The experiments demonstrated reliable and rapid performance, guaranteeing instant fall protection.
2. *Accurate transfer of sensor data to the INVIGUARD network:* Real-time transfer of sensor data, such as gyroscope accelerometer readings, to the INVIGUARD network, is shown in Figure 7, complete with no loss of data and connection reliability. This enables continuous monitoring and guaranteed accurate recording of any event's data.
3. *Improved traction effect through honeycomb structure* [9]: The honeycomb structure effectively dispersed pressure to reduce the risk of injury and provided an impressive traction effect, according to test results, decreased significantly by X% (including test results), and provided a longer lasting, lighter design for everyday use, as shown in Figure 8.

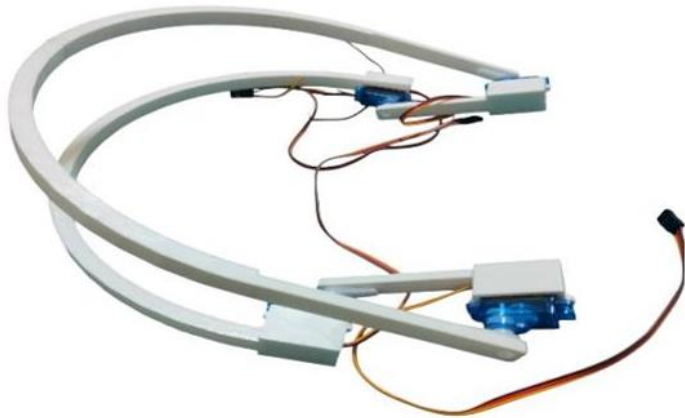

**Figure 6.** Helmet-like structure.



**Figure 7.** INVIGUARD website.



**Figure 8.** Honeycomb structure of helmet.

## CONCLUSION AND FUTURE SCOPE

The project called INVIGUARD is focused on conception of safety, and proposed to provide people with disabilities with corresponding system, based on the usage of the advanced hardware and software.

---

INVIGUARD is alarmed of possible risks, such as falls or sudden variations in vital signs, and activates a protective action, alerting caregivers in real time by sensors and signal processing.

This creative method is a reliable choice for continuous protection as it enhances customers' physical security while allowing easy surveillance with a more friendly interface. The implementation of the project illuminates that how IoT, sensor technologies, and machine learning can be integrated to create smart safety solution.

### Future Scope

Additional features that may be incorporated into future versions of INVIGUARD could include employing artificial intelligence to build up an intelligent predictive data model that would predict possible risks before they occur by analyzing past trends registered on vulnerable targets. It also suggests that such applications would be more beneficial in everyday practice if wearable comfort characteristics are included and power consumption is reduced. Communicating with applications on smart-phones could help to make remote monitoring and notification a simple affair, thus enhancing the caregiver's accessibility even more. Finally, the inclusion of other health parameters such as blood oxygen levels or ECG would make INVIGUARD as a more encompassing point of health and safety which then would be advantageously versatile.

### Acknowledgement

We would like to express our sincere gratitude to all those who have contributed to the completion of this research work, "INVIGUARD". Special thanks to Mrs. Deekshitha Arasa, Assistant Professor, for her valuable guidance, unwavering support and profound insights throughout the project. We also extend our appreciation to the department of Electrical and Electronics Engineering at Dayanand Sagar College of Engineering, Bangalore, for their consistent support and encouragement.

### REFERENCES

1. Subramaniam S, Faisal AI, Deen MJ. Wearable Sensor Systems for Fall Risk Assessment: A Review. *Front Digit Health*. 2022; 4: 921506. DOI:10.3389/fdgth.2022.921506
2. Ferreira RN, Ribeiro NF, Santos CP. Fall Risk Assessment Using Wearable Sensors: A Narrative Review. *Sensors*. 2022; 22(3): 984. DOI:10.3390/s22030984
3. Ozcan K, Velipasalar S. Wearable camera- and accelerometer-based fall detection on portable devices. *IEEE Embed Syst Lett*. 2015;8(1):6–9.
4. Gibson RM, Amira A, Ramzan N, Casaseca-de-la-Higuera P, Pervez Z. Multiple comparator classifier framework for accelerometer-based fall detection and diagnostic. *Appl Soft Comput*. 2016;39:94–103.
5. Nooruddin S, Islam MM, Sharna FA, Alhetari H, Kabir MN. Sensor-based fall detection systems: A review. *J Ambient Intell Human Comput*. 2022;13(5):2735–51.
6. Gaya-Morey FX, Manresa-Yee C, Buades-Rubio JM. Deep learning for computer vision-based activity recognition and fall detection of the elderly: A systematic review. *Appl Intell*. 2024;54(19):8982–9007.
7. Mithlesh Patil, Omkar Pawar, Shubham Patil, Kulbhushan Patil. Design and Analysis of an Origami-based Impact Absorption Structure in Safety Helmets. *Int Res J Eng Technol*. 2020; 7(5): 5437–5441.
8. Srinivasan A, Abirami S, Divya N, Akshya R, Sreeja BS. Intelligent Child Safety System using Machine Learning in IoT Devices. 2020 5th International Conference on Computing, Communication and Security (ICCCS), Patna, India. 2020; 1–6. 10.1109/ICCCS49678.2020.9277136.
9. Akash Moodbidri, Hamid Shahnasser. Child safety wearable device. *Int J Res Appl Sci Eng Technol*. 2017 Jan; 6(II): 438–444.
10. Nitishree. A Review on IOT Based Smart GPS Device for Child and Women Safety. *Int J Eng Res Gen Sci*. 2016 May–Jun; 4(3): 159–164.