

Reliable and Secure Audio Transmission in Underwater Communication Using Li-Fi

B. Vijayalakshmi^{1*}, K. Bhavyasri², M. Jhansi², Ch. Lavanya², D. Bhavana²

Abstract

Ensuring the security of audio transmission becomes crucial as underwater communication systems become more and more important in a variety of areas, including defense, marine research, and offshore organizations. For this reason, Li-Fi technology is an innovative solution that uses its immunity to electromagnetic interference to get around the restrictions of conventional radio frequencies. Li-Fi allows for high-speed data transfer while reducing interference and signal degradation by encoding audio onto light waves. It highlights the benefits of Li-Fi over RF techniques for underwater communication and investigates how encryption algorithms might be integrated to improve data security. The study discusses the difficulties associated with underwater communication, such as signal attenuation and monitoring susceptibility, and it offers a thorough solution that combines authentication procedures and encryption techniques to guarantee the integrity and confidentiality of audio data. To improve the dependability of communication systems in difficult aquatic situations, this research presents new approaches to the essential demand for secure audio transmission in underwater environments.

Keywords: Underwater communication, security, audio transmission, Li-Fi technology, radio frequencies, encryption algorithms

INTRODUCTION

Underwater Secure Audio Transmission (USAT) is essentially a method of transmitting audio or sound over water that is private and impenetrable. This is particularly significant for operations such as defense missions, military operations, or deep-sea research, when maintaining the confidentiality of communications is essential. Water is problematic for sound, as it absorbs sound or interferes with the transmission, making it more difficult to transmit sound underwater than in air. For that reason,

even in busy underwater situations, specific equipment is required to ensure that sound may travel safely and clearly.

*Author for Correspondence

B. Vijayalakshmi
E-mail: Author-zbvl@gvpcew.ac.in

¹Associate Professor, Department of Electronics and Communication Engineering, Gayatri Vidya Parishad College of Engineering for Women, Visakhapatnam, Andhra Pradesh, India

²Student, Department of Electronics and Communication Engineering, Gayatri Vidya Parishad College of Engineering for Women, Visakhapatnam, Andhra Pradesh, India

Received Date: January 23, 2025
Accepted Date: January 31, 2025
Published Date: February 08, 2025

Citation: B. Vijayalakshmi, K. Bhavyasri, M. Jhansi, Ch. Lavanya, D. Bhavana. Reliable and Secure Audio Transmission in Underwater Communication Using Li-Fi. Trends in Opto-electro & Optical Communication. 2025; 15(1): 23–29p.

Underwater communication systems are crucial in defense, marine research, and offshore industries. However, conventional radio frequency (RF) techniques face challenges like signal attenuation and susceptibility to interference. This study suggests using Li-Fi technology for secure audio transmission underwater due to its immunity to interference and high-speed data transfer via light waves. To address these challenges, this study proposes a novel approach utilizing Light Fidelity (Li-Fi) technology for secure audio transmission in underwater environments. Li-Fi offers several advantages over RF techniques, including immunity

to electromagnetic interference and the ability to achieve high-speed data transfer by encoding audio onto light waves. By leveraging Li-Fi technology, this research aims to enhance the reliability, security, and efficiency of underwater communication systems.

Furthermore, the study explores the integration of encryption algorithms into the proposed system to ensure the confidentiality and integrity of transmitted audio data. By encrypting audio signals before transmission and decrypting them upon reception, the system mitigates the risk of unauthorized access or tampering, thereby enhancing data security in challenging aquatic environments [1–12].

Smart approaches are used by USAT systems to ensure safe and clear underwater communication. They use signal processing to eliminate noise, encryption to jumble the message so that no one can listen in, and frequency modulation to change the pitch of the sound [13, 14].

Security is a major issue since underwater acoustic networks, or UWANs, are frequently installed in harsh and occasionally hazardous conditions. These networks are crucial for applications that rely on secure data transmission, such as harbor security, submarine communications, and coastal defense. However, UWANs face challenges in defending themselves against security threats due to their minimal resources. These problems have been the focus of numerous research projects, and several overview publications have outlined the key discoveries in this field [15].

UWSNs, or underwater wireless sensor networks, are exciting technology for many underwater applications. For reliable and smooth data delivery, energy-efficient routing protocols are one of the most crucial elements for these networks to function properly [16].

For example, these techniques are crucial for communicating with submarines, operating underwater drones, and utilizing robotics for military or research purposes. They ensure that the signals remain clear and confidential, even in the noisy and complex underwater environment.

LITERATURE REVIEW

Underwater communication presents significant hurdles due to factors like signal degradation, limited bandwidth, and interference. When used underwater, conventional techniques like radio-frequency (RF) and auditory communication have difficulties. A potential option is visible light communication (VLC), which transfers data using visible light waves. VLC is ideally suited for underwater conditions because of its benefits, which include increased bandwidth and interference resistance. The use of VLC in underwater communication is still in its infancy, despite its potential. Innovative opportunities for underwater communication have been made possible by developments in wireless control system technologies. In comparison with previous research, the present work tries to improve the security of audio transmission in underwater environments by combining Li-Fi technology with modern encryption methods. The new authentication methods and encryption strategies are designed especially for underwater communication systems, building on earlier research [17–19].

Some of the literature reviews on underwater communication using Visible Light Communication (VLC) and security enhancements, challenges, applications, recent advancements, recent directions and future advancements of various papers are briefly discussed below [6]:

Challenges in Underwater Communication

An LED-based Visible Light Communication (VLC) system transmits data by rapidly varying the LED light's brightness at a pace too rapid for the human eye to detect. This indicates that light and fast data transfer can both be provided simultaneously by technology. VLC is therefore seen as an affordable, safe, and convenient method of data transmission, which makes it an excellent choice for the last link in data networks in the future [20].

The growing issue of frequency interference in wireless communication, particularly with Wi-Fi, is highlighted by Chakraborty *et al.* in their paper [21]. They introduced Li-Fi (Light Fidelity), a novel technology that uses light for incredibly fast wireless connections, to address this problem. The study examines the latest advancements in Li-Fi in detail, demonstrating how it may provide a more effective way to address the problems with conventional wireless systems.

Using Visible Light Communication (VLC), Karthika and Balakrishnan proposed a method for transferring files and data between two PCs using UART serial communication [22]. The data is sent via light from an LED at the transmitting end, which is managed by a PIC microcontroller. The light signal is captured by photodiodes on the receiving end. To facilitate the successful transmission of files between the two computers, the PIC microcontroller additionally transforms the received data into a format that the PC can understand.

Various studies highlight the limitations of existing underwater communication methods. Acoustic Communication: While widely used, acoustic systems suffer from low data rates and signal attenuation due to absorption and scattering [23]. Enhancing underwater communication has been a focus of research to aid in understanding climate change, forecasting natural disasters, studying the ocean ecosystem, monitoring marine life, and collecting critical data. Making sure that communication is dependable, quick, and power-efficient is the primary goal [24].

Visible Light Communication (VLC)

VLC has gained attention for underwater communication due to its higher bandwidth capabilities. The basic principles are that VLC utilizes visible light waves to transmit data. Studies show that it can achieve data rates significantly higher than acoustic methods [25]. The advantages are increased bandwidth and lower interference from other signals. For instance, a study by Khan demonstrated VLC's potential to overcome many limitations faced by acoustic systems.

Visible Light Communication (VLC) has become more popular because of the replacement of fluorescent lamps with LEDs due to advancements in solid-state lighting, according to Khan. The study provides a general review of VLC, including its potential uses, system architecture, various signal transmission methods (modulation techniques), standardization initiatives, and the difficulties researchers are encountering. The expanding importance of VLC in communication is emphasized, as is the ongoing effort to standardize and enhance the technology [26].

Applications of VLC in Underwater Communication

A group of Autonomous Underwater Vehicles (AUVs) collaborate to establish dependable underwater optical communication lines in the study by Hanjiang *et al.* [27]. This is a revolutionary concept. The difficulties caused by the ocean's constantly shifting circumstances are intended to be addressed by this method, particularly when sending live video. To do this, the team first creates a model that accounts for the peculiarities of the marine environment and describes how optical signals go underwater. Afterward, they determine the ideal angle for optical communication and the farthest connection it can stay stable. The reason this distance matters is that it guarantees error-free video transmission with a steady, clear signal [27].

The study conducted by Vijayalakshmi *et al.* examines the challenges of underwater communication, particularly with regard to real-time data. They put a lot of effort into determining the most effective link configurations and communication techniques for underwater settings. Their study contributes to the understanding of the most dependable combinations of communication protocols and networks for data transmission under the demanding and constantly shifting conditions [28].

Security in Underwater Communication

The integration of security protocols is critical for safeguarding data transmitted via VLC:

- *Encryption Techniques:* A novel method of encrypting audio files is presented in the work by Krasimir Kordov [29]. The technique employs a cryptographic algorithm that is derived from

traditional encryption models, although it has been modified. It makes use of a modified rotation equation and a chaotic circle map to create a pseudo-random number generator. This new generator makes it more difficult for anyone to access the original content by generating random bit-level alterations in the audio files. The encryption method is especially made to safely safeguard audio data.

Recent Advances

Innovative research is exploring the synergy between VLC and modern security technologies:

As the need for wireless resources grows, Visible Light Communication (VLC) has become a viable option in recent years. The capacity to function in unlicensed spectrum and its high data transmission rates make VLC an attractive substitute for conventional radio frequency (RF) communication. Research has concentrated on physical and MAC layer optimization strategies to lower interference and enhance communication performance. This article examines the most recent developments in VLC technology as well as some possible uses for it [13].

Li-Fi Applications: The use of Li-Fi (Light Fidelity) technology, an extension of VLC, is emerging in underwater contexts, promising enhanced data rates and secure communication [30].

Future Directions

Several areas warrant further exploration:

- *Hybrid Systems:* Combining VLC with other communication methods could provide more robust solutions for varied underwater conditions [31].
- *Advanced Security Measures:* Ongoing research into novel cryptographic techniques specific to VLC environments will enhance security [29].

PROPOSED SYSTEM

The proposed system consists of two main components: the transmitter and the receiver (Figures 1 and 2). The transmitter is responsible for converting audio signals into modulated light signals, while the receiver receives the transmitted light signals and converts them back into audible audio signals. Each component within the system fulfils specific functions to ensure reliable audio transmission and playback.

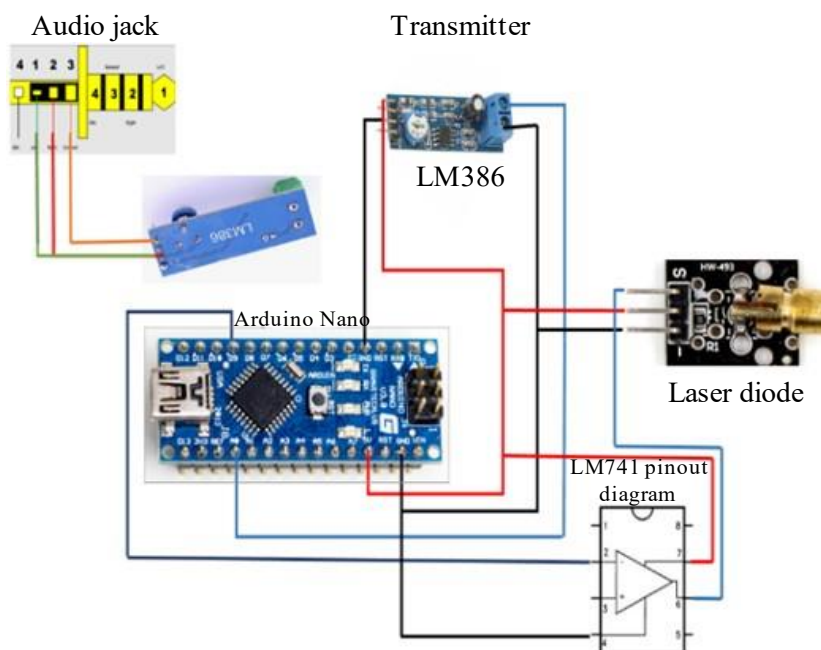

Figure 1. Block diagram of Transmitter.

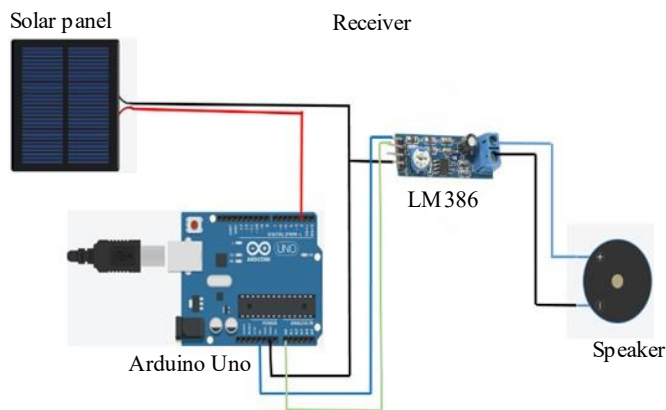

Figure 2. Block diagram of Receiver.

The transmitter section consists an audio jack for inputting audio signals, an LM386 audio amplifier module to amplify the audio signals, an Arduino Nano for digital signal processing, and an operational amplifier to amplify the digital output signal. Before modulation and transmission, the audio signals are encrypted using a secure encryption algorithm implemented on the Arduino Nano.

This encryption process helps prevent unauthorized access or tampering with the audio data during transmission. The final stage of the transmitter involves a laser diode, which converts the amplified digital signal into light for transmission.

On the receiver side, a solar panel is used to capture the transmitted light signals and convert them back into electrical signals. These electrical signals are then stabilized and buffered using an LM358 voltage buffer. An Arduino Uno microcontroller receives the stabilized electrical signals for further processing. The receiver first performs decryption of the received audio data to recover the original audio signals. This decryption process is carried out using a corresponding decryption algorithm implemented on the Arduino Uno microcontroller. The analog output from the Arduino Uno is then amplified using another LM386 audio amplifier module, and finally, the audio signal is reproduced through a speaker.

CONCLUSION

However, the Li-Fi technology is an appropriate replacement which employs its immunity to electromagnetic interference to get beyond the restrictions of traditional radio frequencies. By encoding sound onto light waves, Li-Fi reduces interruption and signal degradation and allows for high-speed data transfer. The study also covers the incorporation of encryption algorithms to enhance data security, as well as difficulties with signal attenuation and monitoring susceptibility in underwater communication. It provides a complete response that includes authentication and encryption techniques to guarantee the confidentiality and integrity of audio data. This advances the creation of reliable communication network in aquatic environments.

Future Scope

The integration of autonomous underwater vehicles (AUVs) and robotic systems stands out as a promising future scope for this project. By collaborating with these technologies, the system can extend its reach and efficiency in deep-sea exploration. This integration enables remote operation, secure communication, and real-time data transmission, enhancing research capabilities while minimizing risks to human divers. Overall, integrating the system with autonomous underwater vehicles and robotic systems holds immense potential to revolutionize underwater research by expanding its reach, improving data collection capabilities, and fostering collaboration between human researchers and autonomous systems. This future scope aligns with the project's goal of advancing understanding and preservation of aquatic ecosystems while contributing to sustainable management.

REFERENCES

1. Sharma RR, Sanganal A, Pati S. Implementation of a simple Li-Fi based system. *Int J Comput Technol.* 2014 Oct 1; 1(9): 437–43.
2. Minglun Z, Peng Z, Yinjie J. A 5.7 Km visible light communications experiment demonstration. In 2015 IEEE 7th international conference on ubiquitous and future networks. 2015 Jul 7; 58–60.
3. Bhut JH, Parmar DN, Mehta KV. LI-FI Technology–A Visible Light Communication. *Int J Eng Dev Res.* 2014 Jan; 4(2): 25–8.
4. Amrutha S, Mathew A, Rajasree R, Sugathan S, Aravind S. A visible light communication system for indoor application. *International Journal of Engineering and Innovative Technology (IJEIT).* 2014 Jun; 3(12): 2014–40.
5. Kaushal H, Kaddoum G. Underwater optical wireless communication. *IEEE Access.* 2016 Apr 11; 4: 1518–47.
6. Jovicic A, Li J, Richardson T. Visible light communication: opportunities, challenges and the path to market. *IEEE Commun Mag.* 2013 Dec 19; 51(12): 26–32.
7. Gabriel C, Khalighi MA, Bourennane S, Léon P, Rigaud V. Investigation of suitable modulation techniques for underwater wireless optical communication. In 2012 IEEE International Workshop on Optical Wireless Communications (IWOW). 2012 Oct 22; 1–3.
8. Jana S, Dutta N, Maji AK, Pal RK. A novel time-stamp-based audio encryption scheme using sudoku puzzle. In *Proceedings of International Conference on Frontiers in Computing and Systems: COMSYS 2021.* Singapore: Springer Nature Singapore; 2022 Jun 28; 159–169.
9. Kumar A, Dua M. Audio encryption using two chaotic maps based dynamic diffusion and double DNA encoding. *Appl Acoust.* 2023 Feb 28; 203: 109196.
10. Wu R, Gao S, Wang X, Liu S, Li Q, Erkan U, Tang X. AEA-NCS: An audio encryption algorithm based on a nested chaotic system. *Chaos Solitons Fract.* 2022 Dec 1; 165: 112770.
11. Wang X, Su Y. An audio encryption algorithm based on DNA coding and chaotic system. *IEEE Access.* 2019 Dec 31; 8: 9260–70.
12. Abdelfatah RI. Audio encryption scheme using self-adaptive bit scrambling and two multi chaotic-based dynamic DNA computations. *IEEE Access.* 2020 Apr 10; 8: 69894–907.
13. Geng Z, Khan FN, Guan X, Dong Y. Advances in visible light communication technologies and applications. *Photonics.* 2022 Nov 23; 9(12): 893. MDPI.
14. Gupta S, Roy D, Bose S, Dixit V, Kumar A. Illuminating the future: A comprehensive review of visible light communication applications. *Opt Laser Technol.* 2024 Oct 1; 177: 111182.
15. Jiang S. On securing underwater acoustic networks: A survey. *IEEE Commun Surv Tutor.* 2018 Aug 7; 21(1): 729–52.
16. Han G, Jiang J, Bao N, Wan L, Guizani M. Routing protocols for underwater wireless sensor networks. *IEEE Commun Mag.* 2015 Nov 9; 53(11): 72–8.
17. Chaudhary AK, Shukla S, Singh S. Analysis of underwater wireless communication using visible light LEDs. In 2020 IEEE International Students' Conference on Electrical, Electronics and Computer Science (SCEECS). 2020 Feb 22; 1–4.
18. Arun Kumar P, Naresh Subray Harikant, Malashree AV, Sridhar N, Venkateswaran K. Development of Data Transmission Model for Under Water Communication using Li-Fi Technology. 5th International Conference on Communication and Electronics Systems. 2020; 312–316.
19. Islam MS, Younis MF. Analyzing visible light communication through air-water interface. *IEEE Access.* 2019; 7: 123830–123845.
20. Ruonan Ji, Shaowei Wang, Qingquan Liu, Wie leu. High speed visible light communications: Enabling Technologies and State of the Art. *MDPI, Appl Sci.* 2018; 8(4): 589.
21. Anwesha Chakraborty, Trina Dutta, *et al.* Latest advancement in Light Fidelity (Li-Fi) Technology. *Int J Adv Res Comput Sci Manag Stud.* 2017; 5(12): 47–53.
22. Karthika R, Balakrishnan S. Wireless communication using Li-Fi technology. *SSRG Int J Electron Commun Eng.* 2015 Mar 25; 2(3): 32–40.
23. Urick RJ. *Principles of Underwater Sound.* McGraw-Hill; USA. 1983.

24. Menaka D, Gauni S, Manimegalai CT, Kalimuthu K. Challenges and vision of wireless optical and acoustic communication in underwater environment. *Int J Commun Syst.* 2022 Aug; 35(12): e5227.
25. Ali MF, Jayakody DN, Li Y. Recent trends in underwater visible light communication (UVLC) systems. *IEEE Access.* 2022 Feb 8; 10: 22169–225.
26. Khan LU. Visible light communication: Applications, architecture, standardization and research challenges. *Digit Commun Netw.* 2017 May 1; 3(2): 78–88.
27. Luo H, Wang X, Bu F, Yang Y, Ruby R, Wu K. Underwater real-time video transmission via wireless optical channels with swarms of AUVS. *IEEE Trans Veh Technol.* 2023 May 25; 72(11): 14688–703.
28. Vijayalakshmi BA, Lekashri S, Gomathi M, Ashwini R, Arunsundar B, Nesasudha M. VLC system using LEDs for transmitting underwater information. *J Opt.* 2024 Jun 18; 1–0.
29. Kordov K. A novel audio encryption algorithm with permutation-substitution architecture. *Electronics.* 2019 May 11; 8(5): 530.
30. Kumar A, Harikant NS, Malashree AV, Sridhar N, Venkateswaran K. Development of Data Transmission Model for Under Water Communication using Li-Fi Technology. In 2020 IEEE 5th International Conference on Communication and Electronics Systems (ICCES). 2020 Jun 10; 317–321.
31. Noor K, Shahid H, Obaid HM, Rauf A, Yousaf A, Shahid A. Hybrid underwater intelligent communication system. *Wirel Pers Commun.* 2022 Aug; 125(3): 2219–38.