

Development of a Self-Cleaning Mechanism for Solar Panels to Enhance Efficiency

S. Rajendra Prasad^{1,*}, Nellampani Pavan Kumar²

Abstract

On Earth, solar energy is the most plentiful source of energy. As it happens, the heat generated by the fusion of helium on the outermost part of the Sun additionally happens to be renewable. This energy is becoming popular because of natural advantages. In digital circuit design, AI can aid in logic synthesis and analog circuit design, AI can help in sizing transistors. The tools used to transform daylight into battery power are called photovoltaic (PV) modules. When photons of light impact activated the silicon junction panels, they form electrons, which create a potential difference across the junction and cause current to flow. Although a great deal of advanced research is being conducted in the fields of materials engineering either silicon junction, etc. to fully realize the promise of solar energy, the maximum efficiency that has been commercially attained only reaches 16–22%. While performance rises when more photons strike the junction, the amount of photons that reach the Si junction decreases when dust settles on these photovoltaic panels, significantly lowering productivity. In digital circuit design, AI can aid in logic synthesis and analog circuit design, AI can help in sizing transistors. Currently, the panels are cleaned by hand, which is labor-intensive, time-consuming, and not advantageous. Therefore, a system that would solve all of these issues is necessary. An extensive analysis of the impact of dust settlement on photovoltaic module performances is carried out in this paper. Dust, filth, and moisture reduce the performance of solar power panels, making them less helpful and less efficient. This study focuses on the development of an automated solar panel cleaning system that is both advantageous and maintains the highest level of efficacy by keeping the screens' upper layer clean.

Keywords: Photo Voltaic modules, silicon junction, solar panels, solar energy, efficiency

INTRODUCTION

Photovoltaic array installations are becoming more prevalent around the world. Over the course of their 20–25 year expected lifetime, each of these solar parks must optimize its power-generating capacity. The sun's spectral content and available irradiance, in addition to other elements like

component performance, inherent system, and environmental and climatic conditions, all affect how much energy solar photovoltaic modules can generate. The performance of photovoltaic (PV) panels is adversely affected by the collection of dust and debris on their surface. The amount of electricity your solar panels can generate depends on a number of factors, one of the greatest and simplest to repair being filthy panels. It is a consensus among experts that solar panels with dust accumulation do not generate as much energy as those without. When using solar energy panels in an unpleasant dusty circumstances, a solar panel cleaning system is suggested to ensure optimal power generation.

*Author for Correspondence

S. Rajendra Prasad
E-mail: rsirumalla@gmail.com

¹Associate Professor, Mechanical Engineering, Kamala Institute of Technology & Science, Huzurabad, Telangana, India

²Student, Mechanical Engineering, Kamala Institute of Technology & Science, Huzurabad, Telangana, India

Received Date: April 10, 2024

Accepted Date: May 01, 2024

Published Date: June 13, 2024

Citation: S. Rajendra Prasad, Nellampani Pavan Kumar. Development of a Self-Cleaning Mechanism for Solar Panels to Enhance Efficiency. Journal of Mechatronics and Automation. 2024; 1(1): 1–10p.

Presently, new retail goods typically attain a best sunlight process (solar module efficiency) of about 1 their individual cells. The most efficient mass-produced solar modules (Typical modules, which could measure approximately 1 m × 2 m or 3 ft 3 in × 6 ft 7 in) have power density values of up to 175 W/m²(16.22 W/ft²).

Using conventional cleansers to clean filthy panels can be expensive, time-consuming, harmful to the environment, and can cause corrosion to the solar panel frame. Maintaining optimal performance for the panels requires cleaning them every few weeks, which can be challenging for large photovoltaic systems. Dust, filth, pollen, and other particles that build up on solar panels diminish their photovoltaic efficiency, which is usually in the 20% range. According to Seamus Curran, a faculty member of physics at the University of The city of Houston and the director of the Institute for Nano Network Energy, which focuses on the creation, development, and assembly of nanotechnology, "a dirty solar panel can reduce its electrical charging capabilities for as much as 30 in high dust/pollen or deserts areas". There have been two different kinds of cleanup mechanisms: mechanized and manual. Cleaning by hand of solar panels carries a danger of harming the AR (Anti-reflective) coating, and it is a laborious procedure. As a result, we must create an automated technique for cleaning solar panels that does not harm them. An prohibitively costly, recurrent, and environmentally unfriendly cleaning system is one which employs water. When panels are scrubbed by a composed of water cleaning method, residue is left behind and scratches result. In the process, dampness and dust particles are effectively eliminated without causing scratches thanks to the use of cotton innovation. It can be cleaned and reused. These advantages put this kind of wiping system ahead of traditional manually cleaning systems in many instances.

LITERATURE SURVEY

The Network of Things (IoT) is the most promising field that combines the benefits of the Pervasive Computing (PC) and Wireless Sensor and Actuator Networks (WSAN) domains, according to V. Bhuvaneshwari et al. (2014) [1]. Numerous Internet of Things (IoT) applications have been developed, among IoT experts have highlighted the potential, issues, and challenges associated with IoT as well as the technological requirements that are utilized in IoT, including cellular phones, RFID labels, sensors, actuators, and other devices. The invention of an automated dust detection and cleaning system for dust removal from photo voltaic (PV) modules was presented by Swanand S. Wable et al. (2017) [2]. One of the things that has a detrimental effect on the output of photovoltaic (PV) cells is dust collection, which blocks solar energy from impacting on the module surface and so lowers the system's performance. The device in question reads voltage and senses amperage from the PV and computes power output. It was created using a C-Program and compiled with the help of the Arduino IDE. The system was able to identify power loss caused by dust deposition on the module surface, as demonstrated by the simulation results obtained from the Proteas 8 Expert circuit build. In response, the electric motor cleaned the affected area. The two direct current motors in the automatic solar panel cleaning system are connected in an anti-parallel fashion and are activated at the exact same voltage. They are located along the panel's opposite ends. Track wheels facilitate the connection of motors. Track straps are used to connect a steel strip coated in microfibre along both of the sides and the solar panel. An application configured on the Arduino UNO controls the motor's speed.

According to Manju B. et al. (2017) [3], photovoltaic Panels farms are located in dusty, dirt environments, which are primarily found in tropical nations. A number of things affect how well solar panels work; the primary cause of this decline in power generation is dust and dirt accumulation on the panels. If the panels are not thoroughly cleaned after one to two months, one may typically anticipate a reduction of roughly 40% to 50%. In order to solve this issue and boost generation efficiency, routine module cleaning is required. An automated cleaning robot is being designed to remove dust from the panels at regular intervals.

The management circuit, DC motor, and microfibre (bristles) used in the process are what cleaning the panels. The report outlines the robot's functionality and how it would impact solar farms' ability to produce energy. It will also assist in comprehending the issue that results from failing to disinfect solar panel cells. According to Subhasri. G et al. (2018) [4], energy is one of the biggest difficulties the world is currently experiencing, and in India, the availability of energy has been a serious issue that both urban and rural people. Approximately 60% to 70% of the nation's energy needs are satisfied by fuel wood and agricultural leftovers. The sun radiates solar energy, so it is an energy source that can be generated with enormous potential. It's critical to switch from using petroleum-based electric energy to sources of clean energy. Solar electricity utilization should be expanded as solar power has emerged as an alternative to fossil fuels. Sunshine solar energy systems are typically used in dusty settings, such as those found in tropical nations such as India. The dust builds up on the module's front surface, obstructing sunlight from the sun. It lowers the component's capacity to generate power. If the module's surface is not cleaned for a month, its power output can drop by more as 50% [5]. The module is cleaned by the specified cleaning mechanism, which is operated by Arduino programming. They proposed a sunlight-based scheme that involves aligning the solar photovoltaic arrays and solar thermal collectors toward the sun in order to reduce dust in the PV modules and increase the efficiency of energy production.

AUTOMATIC SOLAR PANEL CLEANING SYSTEM DESIGN AND FABRICATION

The automatic solar panel cleaning system is designed using AutoCad and Unigraphics and as shown in (Figure 1).

Fabrication of Automatic Solar Panel Cleaning System

Photovoltaic (PV) panels, who are grouped in several arrays in a solar farm or solar system, are the primary source of solar power. Never the less even on a single panel within a set, the buildup of dust and debris reduces the efficiency of energy produced by PV panels [6]. The surface of PV panels must be regularly cleaned as a result of these conditions. The labor-intensive cleaning techniques now used for solar power panels are expensive in terms of time and energy, water, and energy used, and they additionally are devoid of automated features. A completely autonomous solar panel cleaning system is suggested as a solution to this issue. Therefore, the design of a robot for self-cleaning the PV panel's surfaces is described in the current endeavor. The robot's mobility is controlled by the design using an Arduino controller system when it is cleaning. The Block Diagram of the Arduino System is as shown in (Figure 3).

As per the dimensions of the design, the automatic solar panel cleaning system is fabricated and as shown in (Figure 2).

Hardware Requires

Transformer, Rectifier, Regulator, Arduino UNO, Switches, LCD, Relay, Relay Driver, and other miscellaneous components are needed. For automatic control, Arduino is the key component and it's a open source platform used for integrating with physical devices. Arduino is made up of an analog changeable circuit board, also known as a microcontroller, and an IDE (Integrated Development Environment) code that runs on a computer and is used to write and upload computer code to the board.

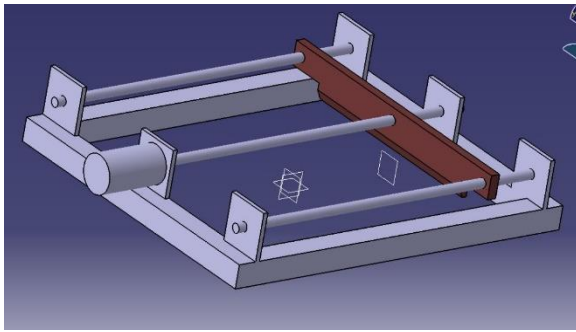

Figure 1. 3D Model of solar panel cleaning system.



Figure 2. Fabricated solar panel cleaning system.

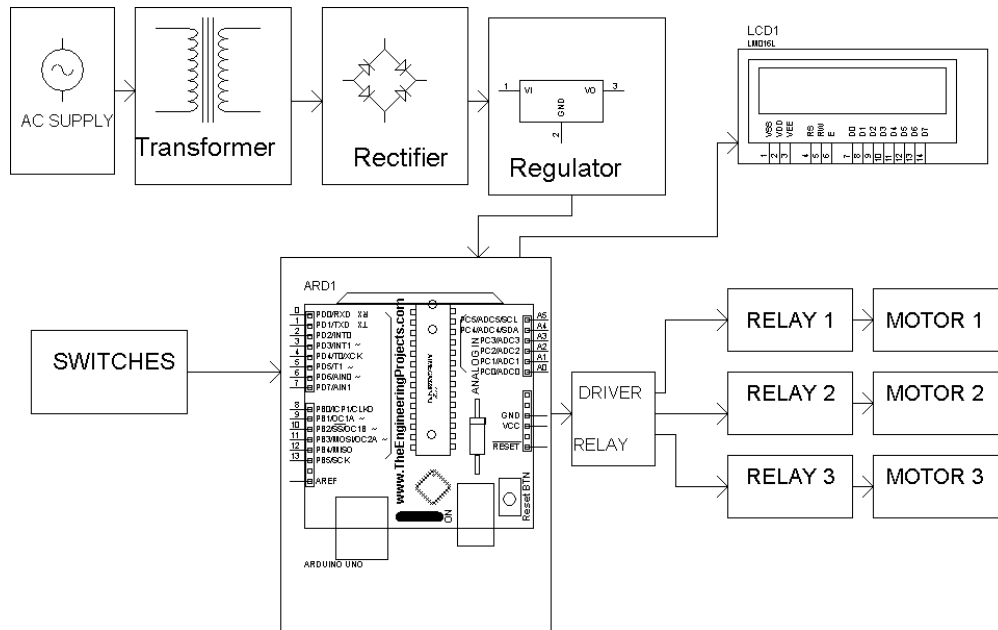

Figure 3. Block diagram of the arduino system.

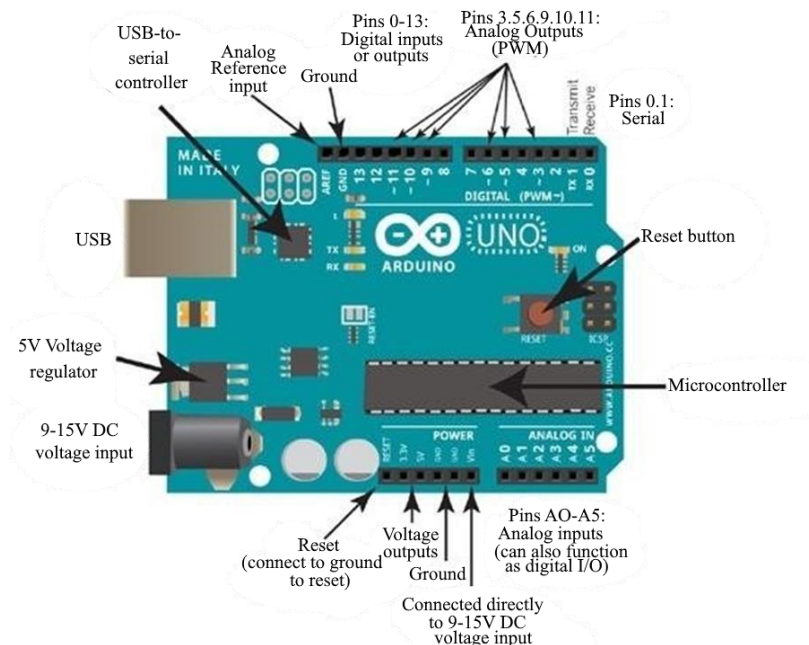

Figure 4. Arduino UNO board.

For good cause, the Arduino platform has grown in popularity among hobbyists in the electronics world. In contrast to the majority of earlier programmable circuit boards, the Arduino may be updated with new code using a USB cable instead of an additional component for hardware known as a programmer. Furthermore, the Arduino IDE employs a condensed form of C++, which facilitates learning to programming. Ultimately, the Arduino offers a common form dimension that simplifies the micro-controllers functionality into an additional manageable bundle. In Figure 4, the example of the Arduino UNO board is displayed.

One of those more well-liked boards created by Arduino, the Uno is a fantastic option for newcomers. Arduino has been the brains behind thousands of projects over the years, ranging from simple household items to sophisticated scientific equipment. Around this freely available platform, a global community of makers—students, amateurs, artists, coders, and professionals—has come together. Their efforts have summed up leading to an amazing quantity of available information that may be very beneficial to both beginners and specialists. It sets itself apart from the competition with its assortment of 8-bit boards, IOT applications, wearables, 3D printing, and embedding environments. Since every Arduino chip is fully free and open-source anyone can construct one on their own and ultimately modify it to suit their specific requirements. Additionally open-source, the program is expanding as a result of global user participation.

Arduino Pin Diagram

The Uno variant of the Arduino is a common example of a board based on Arduino. It consists of ATmega328- a 28 pin microcontrollers and as shown in Figure 5 and Pin Mapping is as shown in (Figure 6).

The Arduino Uno has six analog inputs, a 16 MHz crystal oscillator, fourteen pins for digital input or output (six of which are capable of being used as PWM outputs), a USB port, a power jack, a header for the ICSP, and a reset function.

- **Power Jack:** Arduino can be powered by a source of external power, such as an adapter or a battery, or by a USB connection to a computer. It can run from a 7 to 12V external power. Via the pin Vin, input can be delivered externally, and the IOREf pin can be used to provide a temperature references.

(0.5 KB of which is used for the bootloader), 2 KB of SRAM, and 1 KB of Nand. The basic structure of Arduino is displayed in (Figure 7).

Steps to Program an Arduino

Sketches are Arduino programs written in code. A simple sketch has three components.

1. Variables Declaration
2. *Initialization*: The setup () method contains it.
3. *Control code*: The loop () function is where it is written.
 - The illustration is stored with the .ion suffix. The tool menu and desktop controls can be used for any function, such as opening, saving, or confirming a sketch.
 - The outline needs to be kept in the directories for the sketchbook.
 - Select the appropriate board using the serial port numbers and the tools menu.
 - Either click the save button or select the upload option from the tools menu. Consequently, the microcontroller itself receives the code written by the bootloader.

A few fundamental Arduino operations are:

Reads the digital value at the specified pin using the digital Read(pin) function.

- Digital Write (pin, value): Applies the specified pin with the digital value.
- Pin Mode (pin, mode): Defines the input or output mode for the pin.
- Analog Read(pin): Retrieves the value by reading it.
- Writes the value to the pin using the analog write method (pin, value).
- Recurring. Start (baud rate): By adjusting the bit rate, this command initiates serial communication.

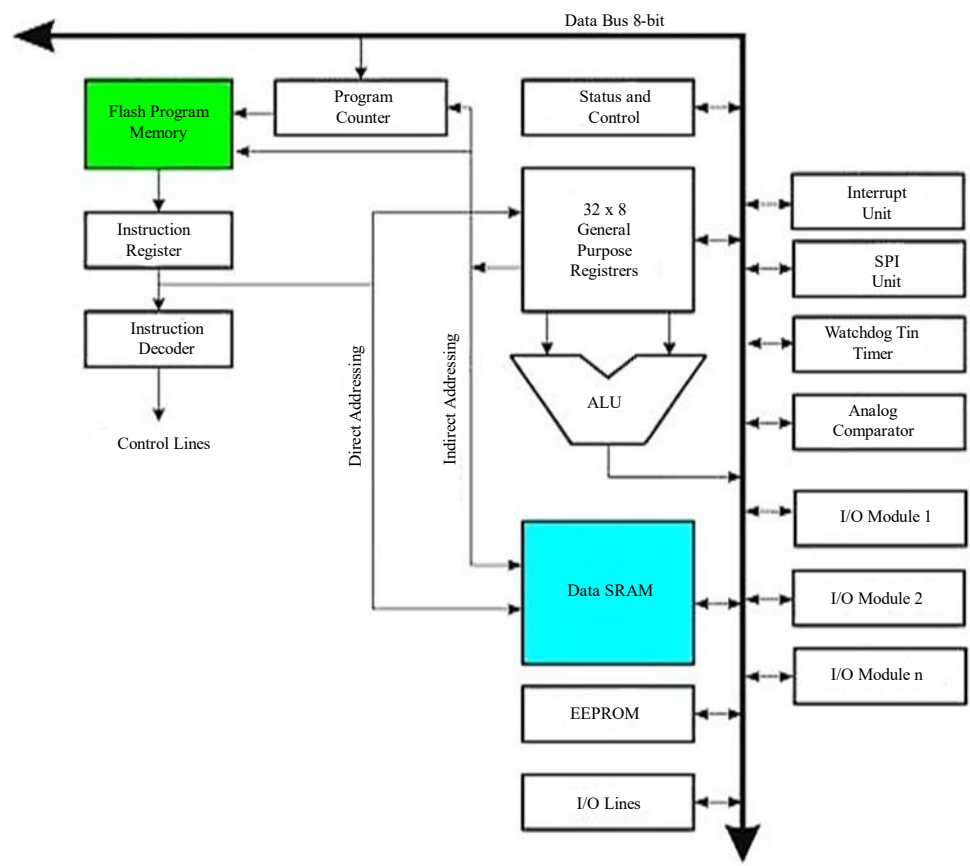

Figure 7. Arduino architecture.

Table 1. Comparison of Solar System and Fuel System

S.N.	Solar System	Fuel System
1	Totally free from pollution	Pollution is a great factor
2	No fuel consumption	Fuel is the important need
3	No. of reciprocating parts are less	No. of reciprocating parts are more
4	Friction is greatly reduced	Frictions between the parts are high.
5	Low cast and maintenance	Maintenance is difficult & costly
6	Load carrying capacity is low	Load carrying capacity is high
7	Continuous ride for hours together is not possible	Continuous ride is possible
8	Ratio of speed reduction more when weight increases very much	Speed reduction ratio is less and it does not vary

The Table 1 below shows the comparison of a solar system with a conventional fuel system. Among the non-conventional sources of energy solar energy is the most promising. Hence this work focuses on the solar energy conversion to mechanical energy to run a cleaning robot and improve the efficiency of the solar panels.

Photovoltaic Principle

The photovoltaic phenomenon is seen in nature in a number of materials, with semiconductors, as previously mentioned, demonstrating the best efficiency when exposed to sunshine. In order for the higher energy free electrons produced by photons absorbed from solar radiation in a semiconductor to flow out of the material and perform beneficial work, an electric field must be present. Most solar cells' electromagnetic radiation is produced by a junction of materials with disparate electrical characteristics, which facilitates photon interaction in a circuit. As seen in Figure 8, a solar cell is composed of a semiconductor, wherein outgoing solar energy is absorbed to form electron-hole pairs.

- Area where a drift field for separating charges is present.
- Charge collecting front and back electrodes.

Environmental Factors Affecting Efficiency of Photovoltaic Panels

The conversion rate of a cell is determined by a number of elements, such as its reflectance efficiency, thermodynamic efficiency, charge carrier separation efficiency, conduction efficiency values, and even the presence of dust on the solar plates. Therefore, in order to boost efficiency, solar plate cleaning is required. Varieties of contamination coming from human activity

- Air pollutants coming from industrial plants (soot, etc.);
- Dust and other air pollutants caused by agricultural activities (tillage, spraying, harvesting);

The following are examples of motor vehicle pollution: dust, carbon black, rubber dust, and carbon monoxide from traditional household heating systems.

The solar panels are susceptible to common but sometimes disregarded on-site realities like dust accumulation, vomit from birds, and water staining, so all which will considerably reduce the solar arrays' efficiency [7]. Dust is a lesser acknowledged factor responsible for decreasing the efficiency of PV installations. As we know solar panels are left under open sky in dusty environment. Dust builds up on the front surface of the panels when they have not been washed for an extended period of time (a few days to several months), which blocks the sun's direct light. As a result, keeping the glass panels clean at regular periods is crucial to preserving their consistent productivity.

Experimental Study on Effect of Dust on PV Panels

In order to investigate the impact of dust, eight weeks of experiments are carried out on photovoltaic panels in the months of January and February.

The radiation is measured during the peak solar isolation hours from 11AM to 2PM. At the conclusion of the eighth week, electricity output per hour had decreased from 1.98kWh to 1.49kWh, representing a 0.49kW loss in power over the course of an hour [8]. The power loss for a year can reach up to 4,292.4kW (approximately) if losses are assumed to be constant and the same operating environment is used. If the tariff rate of solar energy I per unit is taken into consideration as 4.34 Rs, then the roughly calculated amount of that reduction is equal to $4,292.4 \times 4.34$ Rs. Accordingly, the experimental findings lead to the conclusion that routinely cleaning the installed panel can greatly reduce the loss of energy, which, if ignored, can have a significant financial impact. Table 2 shows the experimental results of dust affecting the output of PV panel and Figure 9 showing the Power Output Vs Time.

The main purpose of this study is to develop a fully-automatic self-cleaning mechanism for cleaning the solar panel so that the process can become more reliable and faster, thus increasing the power output of the Solar PV Panel System [9].

Table 2. Showing the experiment results of dust affecting the output of PV panel.

Week	Dust(g/m ²)	Time	Solar Radiation(kwh)	Power Output(kwh)
2 nd week	1.748	11AM TO 2PM	19.90	1.98
4 th week	3.407	11AM TO 2PM	19.13	1.78
6 th week	5.421	11AM TO 2PM	18.43	1.60
8 th week	7.549	11AM TO 2PM	18.03	1.49

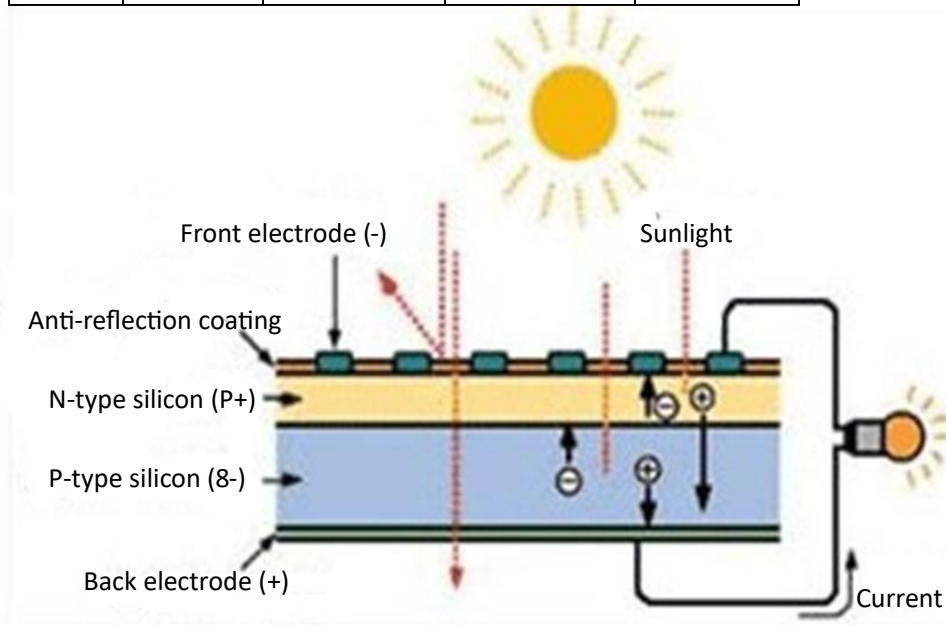

Figure 8. Solar Cell.

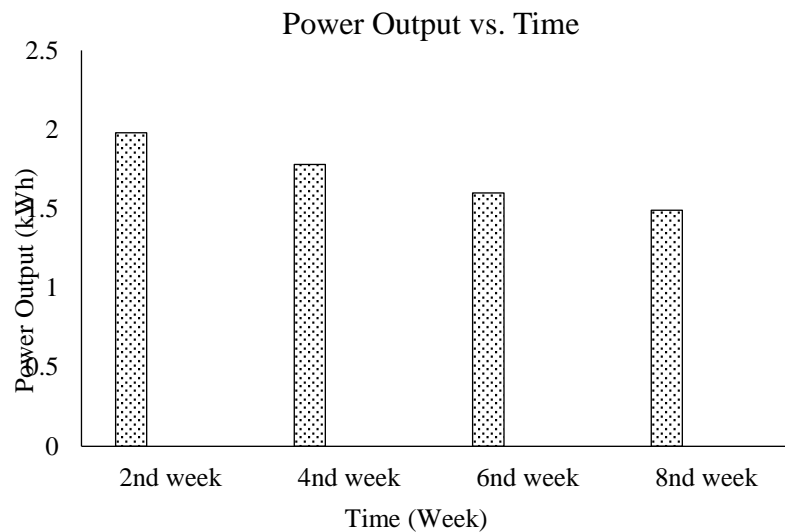

Figure 9. Graph showing the experiment results of power output (kWh) vs. time (Week).

RESULTS AND DISCUSSION

The result shows that the developed solar panel cleaning robot is able to clean the panel effectively and increases the output current as well as the maximum power of the panel by 50%, after the dust on the PV panel is cleaned automatically. The overall total cost of the system is approximately around Rs 12000/- and is affordable. In addition, the gadget requires less maintenance than other systems on the market. It may be managed and the amount of electricity produced across the course of the day tracked via an application for smartphones.

CONCLUSION

Dust accumulation on PV panels can simultaneously reduce the power output and in desert conditions become of the more dust accumulation. The efficiency of the PV power system generation decreases. This potential design mechanism is a simple way to tackle the challenge effectively This solar panel cleaning system.

1. Cleans the panels very effectively.
2. Dust particles are removed very easily.
3. Soot, bird poop, etc. are removed with this cleaning process. Even sticky type material is also cleaned efficiently

Although the promising results were obtained from the prototype, further improvements and techniques are required in order to create a more robust autonomous cleaning solution.

REFERENCES

1. V. Bhuvaneshwari, "The Internet of Things (IoT) Applications and Communication Enabling Technology Standards: An Overview", 2014 International Conference on Intelligent Computing Applications, 978-1-4799-3966-4/14 \$31.00 © 2014 IEEE
2. Swanand S. Wable, Somashekhar Ganiger, "Design & Manufacturing of Solar Panels Cleaning System", International Journal for Research in Applied Science & Engineering Technology (IJRASET), Volume 5 Issue VII, July 2017.
3. Manju B., Abdul Bari and Pavan C M, "Automatic Solar Panel Cleaning System", International Journal of Advances in Scientific Research and Engineering (ijasre), Volume 4, Issue 7, July – 2018.
4. Subhasri.G, Dr. Jeyalakshmi.C, "A Study of IoT based Solar Panel Tracking System", Advances in Computational Sciences and Technology ISSN 0973-6107 Volume 11, Number 7 (2018).

5. Kannan, N., & Vakeesan, D. (2016). Solar energy for future world: A review. *Renewable and sustainable energy reviews*, 62, 1092-1105.
6. X. Liu, S. Yue, L. Lu, and J. Li, "Investigation of the Dust Scaling Behaviour on Solar Photovoltaic Panels," *J. Cleaner Production*, 2021, 126391.
7. N. Sugiarta et al., "Preliminary design and test of water spray solar panel cleaning system," *J. Physics: Conf. Series*, vol. 1450, 012108, Feb. 2020
8. Labay, D. G., & Kinnear, T. C. (1981). Exploring the consumer decision process in the adoption of solar energy systems. *Journal of consumer research*, 8(3), 271-278.
9. Dincer, F. (2011). The analysis on photovoltaic electricity generation status, potential and policies of the leading countries in solar energy. *Renewable and sustainable energy reviews*, 15(1), 713-720.