

IoT and NodeMCU Based Smart Logistics

Nikat Rajak Mulla^{1*}, Kazi Kutubuddin Sayyad Liyakat²

Abstract

Logistics play a key role in global economies, encompassing the planning, implementation, and control of goods' movement. Traditional logistics systems often suffer from inefficiencies, such as manual tracking, delays, and lack of real-time visibility, leading to increased costs and environmental waste. The advent of IoT has revolutionized this sector by enabling interconnected devices to gather augment data seamlessly. At the heart of many IoT applications is NodeMCU. It is favoured for its low cost, ease of programming, and built-in Wi-Fi capabilities, making it ideal for deploying smart solutions in resource-constrained environments. This study delves into how NodeMCU can be utilized to build a smart logistics system, focusing on key components, implementation strategies, and practical outcomes. By leveraging NodeMCU's capabilities for sensor integration, wireless connectivity, and data processing, logistics operations can achieve real-time tracking, prognostic maintenance, and effectual resources management. The discussion highlights the system's architecture, benefits such as cost reduction and improved accuracy, and challenges like security concerns. We proposed a system using Temperature and Humidity sensor, GPS tracker, and Weight sensor. Overall, this approach demonstrates how NodeMCU-based IoT solutions can transform traditional logistics into more agile and data-driven ecosystem, paving the way for sustainable supply chain innovations.

Keywords: Smart logistics, node MCU, IoT, sensors, humidity sensor, GPS

INTRODUCTION

NodeMCU is essentially a development board that simplifies IoT prototyping. It features a Lua-based firmware, GPIO pins for connecting sensors and actuators, and robust wireless connectivity via Wi-Fi or Bluetooth. In the context of smart logistics, NodeMCU serves as the "brain" of IoT devices, enabling the monitoring of assets like shipments, vehicles, and warehouses [1–10].

For instance, NodeMCU can interface with sensors such as GPS modules for location tracking, temperature sensors for monitoring perishable goods, or RFID readers for inventory management. These devices collect data and transmit it to a central cloud server via the internet, allowing stakeholders

to access real-time insights through mobile apps or dashboards.

*Author for Correspondence

Nikat Rajak Mulla

E-mail: nikatmulla786@gmail.com

¹Student, Department of Electronics and Telecommunication Engineering, Brahmdevdada Mane Institute of Technology, Solapur, Maharashtra, India

²Professor & Head, Department of Electronics and Telecommunication Engineering, Brahmdevdada Mane Institute of Technology, Solapur, Maharashtra, India

Received Date: May 13, 2025

Accepted Date: May 16, 2025

Published Date: June 25, 2025

Citation: Nikat Rajak Mulla, Kazi Kutubuddin Sayyad Liyakat. IoT and NodeMCU Based Smart Logistics. Recent Trends in Sensor Research & Technology. 2025; 12(2): 38–50p.

In an era where global trade is more interconnected than ever, the logistics industry faces immense pressure to deliver goods faster, more efficiently, and sustainably. Enter smart logistics, a transformative approach that leverages cutting-edge tools to enhance supply chain processes. From real-time tracking to predictive analytics, smart logistics is reshaping how businesses manage the movement of goods, reducing costs, minimizing waste, and enhancing customer satisfaction. This study explores the key aspects of a smart logistics, its benefits, challenges, and future potential.

At its core, smart logistics states to amalgamation of digital tools into customary logistics processes to create a more intelligent, automated, and responsive system. Unlike conventional logistics, which rely heavily on manual processes and static planning, smart logistics uses data-driven insights to make real-time decisions.

The foundation of smart logistics lies in Internet of Things (IoT), which connects physical assets like trucks, warehouses, and inventory through sensors and devices. This connectivity generates vast quantities of data that can be analysed by artificial intelligence (AI) and machine learning (ML) algorithms. For instance, AI can predict demand fluctuations, optimize routes, and even automate inventory management. Blockchain technology adds another layer by ensuring secure and transparent transactions, while big data analytics provides actionable insights from the deluge of information.

In essence, smart logistics transforms the supply chain into a dynamic ecosystem, where every component communicates seamlessly to improve efficiency and reduce human error.

Several technologies are at the forefront of this revolution, each playing a pivotal role in enhancing logistics operations:

- *IoT*: IoT devices, like GPS trackers, enable real-time checking of assets. For example, a shipping container equipped with IoT sensors can transmit data on its location, temperature, and condition, helping prevent spoilage of perishable goods [11–21].
- *AI and ML*: These technologies analyse chronological and real-time data to forecast trends and automate decisions. AI-powered systems can reroute deliveries based on traffic patterns or weather conditions, saving time and fuel [22–32].
- *Blockchain*: This decentralized ledger ensures traceability and security in supply chain. In industries like pharmaceuticals, blockchain can track the provenance of products, reducing risk of counterfeits and ensuring amenability with regulations.
- *Robotics and Automation*: Warehouses are increasingly automated with robots that handle picking, packing, and sorting. Companies like Amazon have deployed fleets of autonomous robots to streamline operations, cutting down processing times from hours to minutes.

These technologies not only streamline processes but also foster collaboration among stakeholders, from manufacturers to end consumers. The adoption of smart logistics yields numerous advantages, making it a game-changer for businesses across sectors. One of the primary benefits is enhanced efficiency. By optimizing routes and inventory, companies can reduce operational costs by up to 30%, according to a report by McKinsey & Company. This efficiency also translates to faster delivery times, which is crucial in e-commerce, where customers expect packages to arrive within days.

Sustainability is another key gain. Smart logistics minimizes waste by predicting demand accurately, thus avoiding overproduction. For instance, IoT-assisted fleet management schemes might optimize vehicle loads and routes to lower carbon emissions. A notable example is Maersk, the global shipping giant, which uses AI to reduce fuel consumption and greenhouse gas emissions in its operations.

Real-world applications abound. During the COVID-19 pandemic, companies like FedEx leveraged smart logistics to manage surging demand for essential goods. By using AI for demand forecasting and IoT for contactless deliveries, they ensured uninterrupted supply chains despite disruptions. In agriculture, firms are employing drones and sensors to monitor crop conditions and optimize the transport of fresh produce, reducing spoilage and food waste.

Despite its potential, smart logistics is not without hurdles. High implementation costs can deter smaller businesses, as setting up IoT infrastructure and AI systems requires significant investment. Additionally, cybersecurity risks are a major concern; with more devices connected, the supply chain becomes vulnerable to hacks and data breaches.

To report these challenges, concerns are revolving to scalable solutions. Cloud-based platforms offer affordable entry points, allowing businesses to start small and scale up. Governments and industry alliances are also stepping in with regulations and standards to bolster cybersecurity. Moreover, workforce training is essential. As automation rises, there is a need to reskill employees to manage these technologies, ensuring a smooth transition. Looking ahead, smart logistics is poised for even greater advancements. The integration of 5G networks will enable faster data transmission, making real-time decisions instantaneous.

We can also expect greater emphasis on sustainability, with smart logistics playing a key role in achieving net-zero goals. Innovations such as autonomous vehicles and drone deliveries will further disrupt traditional models, potentially transforming last-mile logistics.

As businesses continue to adopt such technologies, the global supply chain becomes more resilient and adaptive, ready to handle future disruptions like climate change or geopolitical tensions.

Smart logistics represents a standard swing in how we manage the complex web of global trade. By binding power of AI, IoT, and other technologies, it offers a pathway to more efficient, sustainable, and customer-centric operations. While challenges remain, the assistances far overshadow the obstacles, tiling way for smarter, more connected world.

For businesses, message is clear: embracing smart logistics is not just an option, it is a necessity for staying competitive. As we move forward, let us leverage these innovations to build supply chains that are not only effectual but also equitable and environmentally answerable.

IOT APPLICATIONS

IoT has moved beyond the buzzword phase and is rapidly transforming how we interrelate with the world. By joining normal objects to internet, IoT empowers us to collect, analyse, and apply data in unprecedented ways, leading to increased efficiency, improved decision-making, and a more connected and convenient life [33–43].

But what exactly are the practical applications of this transformative technology? From optimizing industrial processes to enhancing our personal well-being, the reach of IoT is vast and ever-expanding. Figure 1 explores some key extents where IoT is making a significant effect.

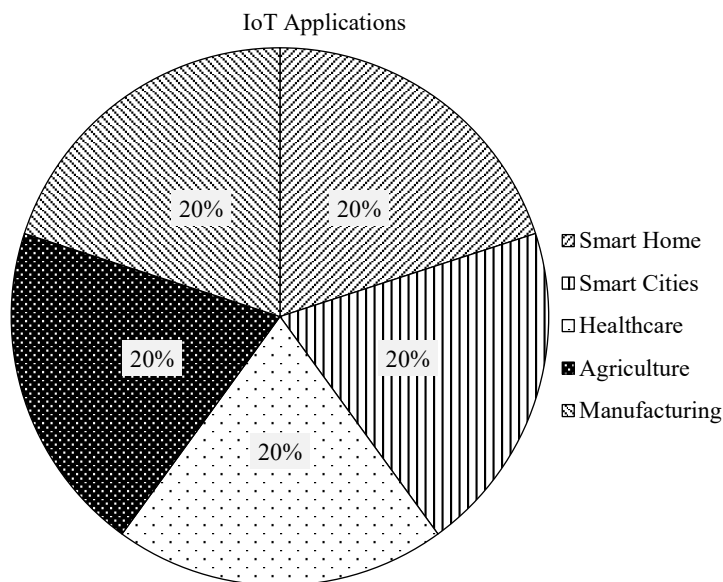

Figure 1. Applications of IoT.

Smart Homes: Comfort, Convenience, and Energy Efficiency

Perhaps most visible application of IoT is in realm of smart homes. Conjure up controlling your lighting, thermostat, security system, and appliances remotely through your smartphone. IoT enables this level of automation and control, leading to:

- *Energy Savings:* Smart thermostats absorb heating and cooling partialities and correct accordingly, minimizing energy waste. Smart lighting systems can automatically adjust based on occupancy and ambient light.
- *Enhanced Security:* Connected sanctuary cameras, doorbells, and anxiety systems provide real-time monitoring and alarms, increasing home security and peace of mind.
- *Increased Convenience:* Voice-controlled assistants like Amazon Alexa and Google Assistant integrate with IoT devices, allowing users to control their home with simple voice commands.

Smart Cities

IoT is playing a vital role in making smarter and sustainable cities. By connecting various urban systems, cities might optimize resource management, improve infrastructure, and enhance quality of lives for their citizens. Some key applications contain:

- *Smart Traffic Management:* Sensors observe traffic flow and alter traffic signals in real-time, dipping congestion and improving travel times.
- *Smart Waste Management:* Connected sensors in bins monitor fill level and improve collection routes, dipping fuel ingesting and pollution.
- *Smart Lighting:* Streetlights fortified with sensors might automatically dim or brighten grounded on ambient light and pedestrian traffic, saving energy and improving safety.
- *Environmental Monitoring:* Sensors monitor water and air quality, and providing that valuable data for ecological protection and public health.

Healthcare: Improving Patient Care and Efficiency

IoT is revolutionising healthcare by allowing remote patient monitoring, improving medication adherence, and streamlining hospital operations. Key benefits include:

- *Remote Patient Monitoring:* Wearable sensors and linked medical devices allow doctors to remotely observe patients' vigorous signs and well-being conditions, enabling early intervention and preventing costly hospitalizations.
- *Medication Adherence:* Smart pill bottles and connected medication dispensers remind patients for taking their medication and track adherence, improving treatment outcomes.
- *Real-Time Location Systems (RTLS):* Hospitals use RTLS to track medical equipment and personnel, improving efficiency and reducing delays in patient care.

Agriculture: Optimizing Crop Yield and Resource Management

IoT is transforming agriculture by allowing agriculturalists to monitor environmental conditions, optimize irrigation, and improve crop yields. Key applications include:

- *Precision Agriculture:* Sensors monitor soil moisture, temperature, and nutrient levels, permitting agriculturalists to optimize irrigation, fertilization, and pest control.
- *Livestock Monitoring:* Wearable sensors track the health and location of livestock, allowing early detection of disease and improved animal welfare.
- *Automated Irrigation:* Smart irrigation schemes automatically alter watering timetables based on weather situations and soil moisture levels, conserving water and improving crop yields.

Manufacturing: Industry 4.0 and the Rise of the Smart Factory

IoT is a key enabler of Industry 4.0, the fourth industrial revolution. By connecting machines, sensors, and other devices, manufacturers can optimize production processes, improve efficiency, and reduce downtime. Key applications include:

- *Predictive Maintenance:* Sensors monitor the performance of machines and predict potential failures, allowing manufacturers to proactively schedule maintenance and avoid costly breakdowns.

- *Asset Tracking*: Connected sensors track location and condition of properties throughout the manufacturing process, improving portfolio management and reducing theft.
- *Real-Time Monitoring and Control*: Data from connected sensors provides real-time discernibility into manufacture processes, permitting manufacturers to optimize performance and respond quickly to changes.

While the possibilities of IoT are immense, there are also challenges that essential to be spoken about, including:

- *Security*: Protecting IoT devices and data they collected from cyberattacks is crucial.
- *Privacy*: Ensuring the privacy of individuals whose data is collected by IoT strategies is vital.
- *Interoperability*: Safeguarding that dissimilar IoT devices and stages can communicate with each other is critical for widespread adoption.

Looking ahead, we expects to see even more advanced applications of IoT emerge in the coming years. As technology continues to advance and costs continue to decline, IoT will become an even more pervasive and integral part of our lives, transforming industries and shaping the future of our world.

IOT IN SMART LOGISTICS

In today's interconnected world, the movement of goods is more complex and demanding than ever before. Customers expect fast, transparent, and reliable delivery, placing immense pressure on logistics companies to optimize every aspect of their operations. Enter IoT that is revolutionizing the logistics industry and ushering in an era of "smart logistics", allows for the collection and exchange of data in real-time. This data provides unprecedented visibility and control across the entire supply chain, enabling businesses to make smarter decisions, streamline processes, and ultimately, deliver a better customer experience [44–54]. But how exactly is IoT being applied in smart logistics? Let us delve into some key applications as shown in Figure 2.

Real-Time Tracking and Monitoring

- *Location Tracking*: IoT-permitted GPS trackers provide accurate, real-time location data for vehicles, containers, and even individual packages. This allows logistics companies to monitor the progress of shipments, identify potential delays, and proactively address any issues.
- *Condition Monitoring*: Sensors might monitor critical environmental factors like temperature, humidity, and shock levels. This is particularly crucial for transporting perishable goods, pharmaceuticals, and other sensitive products, ensuring their integrity throughout the journey.
- *Fleet Management*: IoT sensors integrated into vehicles may collect data on engine performance, fuel consumption, driver performance, and upkeep needs. This data aids to optimise routes, reduce fuel charges, improve vehicle maintenance schedules, and enhance driver safety.

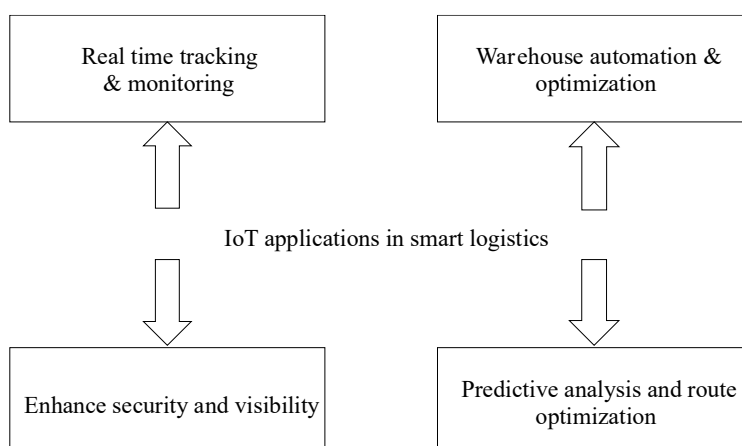

Figure 2. IoT in smart logistics applications.

Warehouse Automation and Optimization

- *Smart Inventory Management:* RFID tags and sensors automatically track inventory levels, reducing the need for manual counting and minimizing stockouts. This enables efficient inventory management and reduces waste.
- *Automated Guided Vehicles (AGVs):* Equipped with sensors and connected to the network, AGVs can autonomously move goods within warehouses, improving efficiency and reducing labour costs.
- *Predictive Maintenance:* IoT sensors will monitor performance of warehouse equipment like forklifts and conveyor belts. By analysing this data, maintenance teams can predict potential failures and schedule preventative maintenance, minimizing downtime.

Predictive Analytics and Route Optimization

- *Demand Forecasting:* By analysing data from past shipments, weather patterns, and other relevant sources, IoT can help predict future demand and optimize inventory levels and resource allocation.
- *Dynamic Route Planning:* Real-time traffic data and other environmental factors can be fed into route optimization algorithms, allowing for dynamic adjustments to delivery routes to avoid congestion and ensure timely delivery.
- *Risk Assessment:* IoT data will be used to recognize potential risks such as traffic accidents, weather-related disruptions, or security threats. This allows logistics companies to proactively mitigate these risks and minimize their impact on operations.

Enhanced Security and Visibility

- *Cargo Security:* IoT sensors can detect unauthorized access to cargo containers or vehicles, triggering alerts and providing real-time tracking data to assist in recovery efforts.
- *Chain of Custody Tracking:* IoT technology provides a transparent and secure record of each step in supply chain, ensuring accountability and minimizing the risk of theft or counterfeiting.

The implementation of IoT in logistics offers a multitude of benefits, including:

- *Increased Efficiency:* Automation, real-time visibility, and optimized routes lead to significant improvements in operational efficiency.
- *Reduced Costs:* Fuel savings, optimized inventory management, and proactive maintenance contribute to lower operational costs.
- *Improved Customer Service:* Real-time tracking, timely delivery, and enhanced transparency lead to increased customer satisfaction.
- *Enhanced Safety and Security:* Improved driver safety, cargo security, and risk mitigation contribute to a safer and more secure supply chain.
- *Data-Driven Decision Making:* Realtime data provides valuable insights that enable better decision-making and improved business outcomes.

While the potential of IoT in logistics is immense, there are also challenges to consider, including:

- *Data Security and Privacy:* Defending sensitive information from cyber threats is crucial.
- *Integration Complexity:* Integrating IoT devices and platforms with existing systems can be challenging.
- *Scalability:* Scaling IoT solutions to meet the needs of a growing business requires careful planning.
- *Cost of Implementation:* Early investment in IoT technology might be significant.

IoT is transforming the logistics industry, empowering businesses with unprecedented visibility, control, and efficiency. By embracing IoT technology, logistics companies can optimize their operations, reduce costs, improve customer service, and gain a competitive edge in today's demanding

market. As the technology continues to evolve, we can expect to see even more innovative applications of IoT in smart logistics, shaping the future of the supply chain [55–63].

PROPOSED METHOD

IoT has transformed various productions, and logistics is no exception. IoT-based smart logistics solutions have enhanced supply chain visibility, streamlined operations, and improved delivery accuracy. At the heart of these solutions lies the Node MCU, a cost-effective, open-source platform that has made it easier for businesses to implement IoT in their logistics operations.

NodeMCU is a low-cost, open-source podium that is founded on the ESP8266 Wi-Fi SoC from Espressif Systems. It is a highly integrated chip designed for wireless communication and can be programmed by the Arduino IDE. NodeMCU features built-in Wi-Fi capabilities, making it ideally superior for IoT-based applications that require wireless communication [64–67].

In the setting of smart logistics, Node MCU can be employed to develop a range of IoT devices, like temperature and humidity sensors, GPS trackers, and weight sensors. These devices can be integrated into logistics operations to provide real-time data, enabling productions to monitor their shipments and optimise their supply chain operations.

Temperature and Humidity Sensors

Temperature and humidity sensors based on NodeMCU can be employed to monitor conditions of perishable goods during transit. These sensors can be placed inside shipping containers or packages to provide real-time data on temperature and humidity levels. This data can be used to ensure that unpreserved goods are kept at the right temperature and humidity levels, reducing the risk of spoilage and waste.

GPS Trackers

GPS trackers based on NodeMCU are used to monitor location and movement of shipments in real-time. These trackers can be placed inside shipping containers or attached to packages to provide accurate location data. This data can be employed to optimise delivery routes, lessen delivery times, and progress delivery accuracy.

Weight Sensors

Weight sensors based on Node MCU can be used to monitor the weight of shipments during transit. These sensors can be placed under shipping containers or pallets to provide real-time data on weight. This data may be used to ensure that shipments are not overloaded, reducing risk of damage and accidents during transit.

Figure 3 shows the proposed system using NodeMCU.

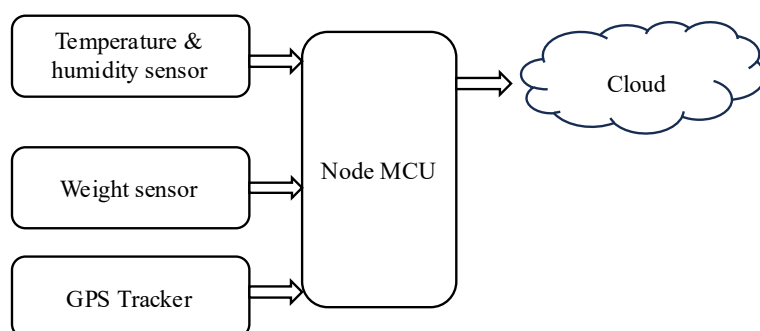

Figure 3. Proposed system.

NodeMCU offers several benefits for businesses looking to implement IoT-based smart logistics solutions. Some of these benefits include:

- *Cost-effectiveness*: NodeMCU is a low-cost solution that is accessible to businesses of all sizes. This makes it an ideal choice for businesses looking to implement IoT-based smart logistics solutions without breaking the bank.
- *Ease of use*: NodeMCU is an open-source platform that can be programmed using the popular Arduino IDE. This makes it easy for businesses to develop and deploy custom IoT devices that meet their specific needs.
- *Realtime data*: NodeMCU-based devices can provide real-time data on temperature, humidity, location, and weight. This data can be employed to optimize supply chain operations, reduce delivery times, and improve delivery accuracy.
- *Improved supply chain visibility*: NodeMCU-based devices can provide real-time data on condition and location of shipments, improving supply chain visibility and enabling businesses to make informed decisions.

NodeMCU is a game-changing platform for businesses looking to implement IoT-based smart logistics solutions. Its cost-effectiveness, ease of use, and real-time data capabilities make it an ideal choice for developing custom IoT devices that can be used to monitor temperature, humidity, location, and weight during transit. By leveraging NodeMCU, businesses can optimize their supply chain operations, reduce delivery times, and improve delivery accuracy, ultimately leading to increased customer satisfaction and revenue growth.

DISCUSSION

Efficient and transparent logistics are vital for businesses of all sizes. From tracking shipments to optimizing routes and managing inventory, the challenges are numerous. Luckily, IoT is offering innovative solutions, and at the heart of many of these lies the humble yet powerful NodeMCU. Its key benefits for smart logistics include:

- *Low Cost*: NodeMCU is incredibly affordable, allowing for cost-effective deployment across a large number of assets and vehicles.
- *Wi-Fi Connectivity*: Seamless integration with existing Wi-Fi networks allows for real-time data transmission and monitoring.
- *Ease of Programming*: Its simple Lua scripting language and extensive online resources make it accessible even for those with limited programming experience.
- *Versatile Functionality*: NodeMCU can interface with a wide range of sensors, enabling collection of crucial data on location, temperature, humidity, and more, easily.
- *Compact Size and Low Power Consumption*: Its small footprint and efficient power usage make it suitable for integration into various logistics components.

Use Cases for Smart Logistics

Here is how NodeMCU-based IoT solutions are transforming logistics operations:

- *Real-Time Shipment Tracking*: By equipping packages or containers with NodeMCU-based trackers, businesses can monitor their location in real-time. This provides greater visibility into the supply chain, allowing for proactive problem-solving and improved customer satisfaction. Imagine knowing exactly where your shipment is at every stage of its journey, and receiving alerts if there are any unexpected delays.
- *Environmental Monitoring During Transit*: Sensitive goods like pharmaceuticals and food often require strict temperature and humidity controls. NodeMCU, coupled with appropriate sensors, can continuously monitor these parameters during transit and alert stakeholders if conditions deviate from acceptable ranges. This prevents spoilage, maintains product integrity, and reduces financial losses.
- *Fleet Management and Route Optimization*: Integrating NodeMCU with GPS modules allows for real-time tracking of vehicles. This data will be used to optimize routes, improve fuel

efficiency, and monitor driver behaviour. Furthermore, integrating environmental sensors helps in deciding which routes have low air pollution, depending on the goods in delivery.

- *Warehouse Management*: NodeMCU can be used to automate inventory tracking and optimize warehouse operations. By connecting sensors to shelves and pallets, businesses can monitor the stock available, reducing risk of stockouts and overstocking.
- *Predictive Maintenance*: By monitoring key performance indicators (KPIs) of vehicles and equipment using NodeMCU-based sensors, businesses can detect potential matters before they lead to breakdowns. This allows proactive maintenance, minimizing downtime and reducing repair costs.

Getting started with NodeMCU for smart logistics is easier than you might think. Here is a basic outline:

1. *Identify the Problem*: Clearly define the specific logistics challenge you want to address.
2. *Choose the Right Sensors*: Select sensors that can collect the data you need (e.g., GPS for location, temperature sensors for environmental monitoring).
3. *Connect and Program*: Connect the sensors to the NodeMCU and program it to collect data, transmit it to a cloud platform, and trigger alerts if necessary.
4. *Choose a Cloud Platform*: Select a cloud platform (e.g., ThingSpeak, Adafruit IO) to store and analyse the data collected by the NodeMCU.
5. *Develop a User Interface*: Create a user-friendly interface for monitoring the data and controlling the system.
6. *Test and Deploy*: Thoroughly test the solution before deploying it in a real-world environment.

CONCLUSION

Node MCU-based smart logistics using IoT represents transformative method to modern supply chain management, posing real-time visibility, predictive capabilities, and operational efficiency. By harnessing the affordability and versatility of NodeMCU, businesses can address traditional logistics inefficiencies and adapt to the demands of a connected world. As IoT technologies continue to evolve, this solution holds immense potential for driving innovation, sustainability, and competitiveness in the logistics industry. Future research should focus on enhancing security measures and integrating AI for more autonomous systems, ensuring that NodeMCU remains at the forefront of smart logistics solutions. NodeMCU is democratizing IoT applications in logistics, making them more accessible and affordable for businesses of all sizes. By leveraging the power of this versatile platform, companies can increase better visibility into supply chains, optimize operations, and ultimately deliver better service to their customers. As the adoption of IoT continues to grow, NodeMCU will undoubtedly remain a key enabler of smarter, more efficient, and more resilient logistics solutions.

REFERENCES

1. Mulani AO, Bang AV, Birajadar GB, Deshmukh AB, Jadhav HM, Liyakat KK. IoT Based Air, Water, and Soil Monitoring System for Pomegranate Farming. *Ann Agri-Bio Res.* 2024; 29(2): 71–86.
2. Parihar B, Kiran A, Valaboju S, Rashid SZ, Liyakat KK, DR AS. Enhancing Data Security in Distributed Systems Using Homomorphic Encryption and Secure Computation Techniques. In *ITM Web of Conferences.* EDP Sciences. 2025; 76: 02010.
3. Gasser M, Goldstein A, Kaufman C, Lampson B. The digital distributed system security architecture. In: *Proceedings of the 12th National Computer Security Conference*; 1989 Oct 10; Baltimore. Washington (DC): National Computer Security Center; 1989. p. 305–19.
4. Veena C, Sridevi M, Liyakat KK, Saha B, Reddy SR, Shirisha N. HEECCNB: An efficient IoT-cloud architecture for secure patient data transmission and accurate disease prediction in healthcare systems. In *2023 IEEE Seventh International Conference on Image Information Processing (ICIIP)*. 2023 Nov 22; 407–410.

5. Liyakat KK, Khadake SB, Tamboli DA, Sawant VA, HM M, Sathe S. AI-Driven-IoT (AIIoT) Based Decision-Making-KSK Approach in Drones for Climate Change Study. In 2024 IEEE 4th International Conference on Ubiquitous Computing and Intelligent Information Systems (ICUIS). 2024 Dec 12; 1735–1744.
6. Prasad KR, Karanam SR, Ganesh D, Liyakat KK, Talasila V, Purushotham P. AI in public-private partnership for IT infrastructure development. *J High Technol Manag Res*. 2024 May 1; 35(1): 100496.
7. Liyakat KK. Detecting malicious nodes in IoT networks using machine learning and artificial neural networks. In 2023 IEEE International Conference on Emerging Smart Computing and Informatics (ESCI). 2023 Mar 1; 1–5.
8. Liyakat KK. Malicious node detection in IoT networks using artificial neural networks: A machine learning approach. In: *Intelligent Networks*. CRC Press; 182–197.
9. Kasat K, Shaikh N, Rayabharapu VK, Nayak M, Liyakat KK. Implementation and recognition of waste management system with mobility solution in smart cities using Internet of Things. In 2023 IEEE Second International Conference on Augmented Intelligence and Sustainable Systems (ICAISS). 2023 Aug 23; 1661–1665.
10. Kazi K. AI-driven IoT (AIIoT) in healthcare monitoring. In: *Using Traditional Design Methods to Enhance AI-Driven Decision Making*. IGI Global Scientific Publishing; 2024; 77–101.
11. Kazi K. Modelling and simulation of electric vehicle for performance analysis: BEV and HEV electrical vehicle implementation using Simulink for E-mobility ecosystems. In: *E-Mobility in Electrical Energy Systems for Sustainability*. IGI Global; 2024; 295–320.
12. Kazi KS. Machine Learning-Powered IoT (MLIoT) for Retail Apparel Industry. In: *Sustainable Practices in the Fashion and Retail Industry*. IGI Global Scientific Publishing; 2025; 345–372.
13. Kazi KS. Braille-Lippi Numbers and Characters Detection and Announcement System for Blind Children Using KSK Approach: AI-Driven Decision-Making Approach. In: *Driving Quality Education Through AI and Data Science*. IGI Global Scientific Publishing; 2025; 531–556.
14. Kazi KS. AI-Driven IoT (AIIoT)-Based Decision-Making System for High BP Patient Healthcare Monitoring: KSK1 Approach for BP Patient Healthcare Monitoring. In: *Optimization, Machine Learning, and Fuzzy Logic: Theory, Algorithms, and Applications*. IGI Global Scientific Publishing; 2025; 71–102.
15. Kazi KS. Advancing Towards Sustainable Energy With Hydrogen Solutions: Adaptation and Challenges. In: *Geopolitical Landscapes of Renewable Energy and Urban Growth*. IGI Global Scientific Publishing; 2025; 357–394.
16. Kazi KS. AI-Driven-IoT (AIIoT) Decision-Making System for Hepatitis Disease Patient Healthcare Monitoring: KSK1 Approach for Hepatitis Patient Monitoring. In: *Navigating Innovations and Challenges in Travel Medicine and Digital Health*. IGI Global Scientific Publishing; 2025; 431–450.
17. Kazi KS. Machine learning-based pomegranate disease detection and treatment. In: *Revolutionizing Pest Management for Sustainable Agriculture*. IGI Global; 2024; 469–498.
18. Kazi KS. Computer-aided diagnosis in ophthalmology: A technical review of deep learning applications. In: *Transformative Approaches to Patient Literacy and Healthcare Innovation*. IGI Global; 2024; 112–35.
19. Kazi KS. IoT driven by machine learning (MLIoT) for the retail apparel sector. In: *Driving Green Marketing in Fashion and Retail*. IGI Global; 2024; 63–81.
20. Liyakat KK, Khadake SB, Tamboli DA, Sawant VA, HM M, Sathe S. AI-Driven-IoT (AIIoT) Based Decision-Making-KSK Approach in Drones for Climate Change Study. In 2024 IEEE 4th International Conference on Ubiquitous Computing and Intelligent Information Systems (ICUIS). 2024 Dec 12; 1735–1744.
21. Liyakat KK, Khadake SB, Tamboli DA, Sawant VA, HM M, Sathe S. AI-Driven-IoT (AIIoT) Based Decision-Making-KSK Approach in Drones for Climate Change Study. In 2024 IEEE 4th International Conference on Ubiquitous Computing and Intelligent Information Systems (ICUIS). 2024 Dec 12; 1735–1744.

22. Liyakat KK, Khadake SB, Tamboli DA, Sawant VA, HM M, Sathe S. AI-Driven-IoT (AIIoT) Based Decision-Making-KSK Approach in Drones for Climate Change Study. In 2024 IEEE 4th International Conference on Ubiquitous Computing and Intelligent Information Systems (ICUIS). 2024 Dec 12; 1735–1744.
23. Liyakat KK, Khadake SB, Tamboli DA, Sawant VA, HM M, Sathe S. AI-Driven-IoT (AIIoT) Based Decision-Making-KSK Approach in Drones for Climate Change Study. In 2024 IEEE 4th International Conference on Ubiquitous Computing and Intelligent Information Systems (ICUIS). 2024 Dec 12; 1735–1744.
24. Sayyad Liyakat KK, Konnur RG. Vehicle Health Monitoring System (VHMS) by Employing IoT and Sensors. *Grenze Int J Eng Technol*. 2024 Jun 15; 10: 5368–5374.
25. KSK. A Novel Approach on ML based Palmistry. *Grenze Int J Eng Technol*. 2024; 10(2): 5186–93. Available from: <https://thegrenze.com/index.php?display=page&view=journalabstract&absid=3344&id=8>.
26. KSK. IoT based Boiler Health Monitoring for Sugar Industries. *Grenze Int J Eng Technol*. 2024; 10(2): 5178–85. Available from: <https://thegrenze.com/index.php?display=page&view=journalabstract&absid=3343&id=8>.
27. Keerthana R, K V, Bhagyalakshmi K, Papinaidu M, V V, Liyakat KKS. Machine learning based risk assessment for financial management in big data IoT credit. *SSRN Electron J*. 2025. <https://doi.org/10.2139/ssrn.5086671>.
28. Kazi K. Explainable AI in Healthcare. In: Kamaraj AA, Acharjya DP, editors. *Explainable Artificial Intelligence in Healthcare System*. Nova Science Publishers; 2024. ISBN: 979-8-89113-598-7. <https://doi.org/10.52305/GOMR8163>.
29. Kazi K. Machine Learning (ML)-Based Braille Lippi Characters and Numbers Detection and Announcement System for Blind Children in Learning. In: Sart G, editor. *Social Reflections of Human-Computer Interaction in Education, Management, and Economics*. IGI Global; 2024. <https://doi.org/10.4018/979-8-3693-3033-3.ch002>.
30. Liyakat KKS. Machine Learning Approach Using Artificial Neural Networks to Detect Malicious Nodes in IoT Networks. In: Shukla PK, Mittal H, Engelbrecht A, editors. *Computer Vision and Robotics. Algorithms for Intelligent Systems*. Singapore: Springer; 2023. https://doi.org/10.1007/978-981-99-4577-1_3.
31. Liyakat KKS. ChatGPT: An Automated Teacher's Guide to Learning. In: Bansal R, Chakir A, Ngah AH, Rabby F, Jain A, editors. *AI Algorithms and ChatGPT for Student Engagement in Online Learning*. IGI Global; 2024; 1–20. <https://doi.org/10.4018/979-8-3693-4268-8.ch001>.
32. Liyakat. IoT Technologies for the Intelligent Dairy Industry: A New Challenge. In: Thandekkattu S, Vajjhala N, editors. *Designing Sustainable Internet of Things Solutions for Smart Industries*. IGI Global; 2025; 321–50. <https://doi.org/10.4018/979-8-3693-5498-8.ch012>.
33. Liyakat KKS. Heart Health Monitoring Using IoT and Machine Learning Methods. In: Shaik A, editor. *AI-Powered Advances in Pharmacology*. IGI Global; 2025; 257–82. <https://doi.org/10.4018/979-8-3693-3212-2.ch010>.
34. Liyakat. AI-Driven-IoT(AIIoT)-Based Decision Making in Kidney Diseases Patient Healthcare Monitoring: KSK Approach for Kidney Monitoring. In: Polat LÖ, Polat O, editors. *AI-Driven Innovation in Healthcare Data Analytics*. IGI Global; 2025; 277–306. <https://doi.org/10.4018/979-8-3693-7277-7.ch009>.
35. Liyakat KKS. Machine Learning Approach Using Artificial Neural Networks to Detect Malicious Nodes in IoT Networks. In: Udgata SK, Sethi S, Gao XZ, editors. *Intelligent Systems. ICMIB 2023. Lecture Notes in Networks and Systems. Vol. 728*. Singapore: Springer; 2024. https://doi.org/10.1007/978-981-99-3932-9_12.
36. Pradeepa M, et al. Student Health Detection using a Machine Learning Approach and IoT. 2022 IEEE 2nd MysuruCon; 2022. Available from: <https://ieeexplore.ieee.org/document/9972445>.
37. Mahant MA. Machine Learning-Driven Internet of Things (MLIoT)-Based Healthcare Monitoring System. In: Wickramasinghe N, editor. *Digitalization and the Transformation of the Healthcare Sector*. IGI Global; 2025; 205–36. <https://doi.org/10.4018/979-8-3693-9641-4.ch007>.

38. Mulani AO, Liyakat KKS, Warade NS, *et al.* ML-powered Internet of Medical Things Structure for Heart Disease Prediction. *J Pharmacol Pharmacother.* 2025; 0(0). <https://doi.org/10.1177/0976500X241306184>.
39. Odnala S, Shanthi R, Bharathi B, Pandey C, Rachapalli A, Liyakat KKS. Artificial Intelligence and Cloud-Enabled E-Vehicle Design with Wireless Sensor Integration. *SSRN Electron J.* 2025. <https://doi.org/10.2139/ssrn.5107242>.
40. Neeraja P, Kumar RG, Kumar MS, Liyakat KKS, Vani MS. DL-Based Somnolence Detection for Improved Driver Safety and Alertness Monitoring. *2024 IEEE Int Conf Comput Power Commun Technol (IC2PCT)*; 2024; 589–94. <https://doi.org/10.1109/IC2PCT60090.2024.10486714>.
41. Magadam PK. Machine Learning for Predicting Wind Turbine Output Power in Wind Energy Conversion Systems. *Grenze Int J Eng Technol.* 2024; 10(1): 2074–80. Available from: <https://thegrenze.com/index.php?display=page&view=journalabstract&absid=2514&id=8>.
42. Nerkar PM, Dhaware BU. Predictive Data Analytics Framework Based on Heart Healthcare System (HHS) Using Machine Learning. *J Adv Zool.* 2023; 44(Suppl 2): 3673–86. Available from: <https://jazindia.com/index.php/jaz/article/view/1695>.
43. Nerkar P, Sultanabonu. IoT-Based Skin Health Monitoring System. *Int J Biol Pharm Allied Sci.* 2024; 13(11): 5937–50. <https://doi.org/10.31032/IJBPAS/2024/13.11.8488>.
44. Khadake SB, Chounde AB, Suryagan AA, MHM, Khadatare MR. AI-Driven-IoT(AIIoT) Based Decision Making System for High-Blood Pressure Patient Healthcare Monitoring. *2024 Int Conf Sustain Commun Netw Appl (ICSCNA).* 2024; 96–102. <https://doi.org/10.1109/ICSCNA63714.2024.10863954>.
45. Sayyad. AI-Powered-IoT (AIIoT)-Based Decision-Making System for BP Patient's Healthcare Monitoring: KSK Approach. In: Aouadni S, Aouadni I, editors. *Recent Theories and Applications for Multi-Criteria Decision-Making.* IGI Global; 2025; 205–38. <https://doi.org/10.4018/979-8-3693-6502-1.ch008>.
46. Sayyad. AI-Powered IoT (AI IoT) for Decision-Making in Smart Agriculture: KSK Approach. In: Hai-Jew S, editor. *Enhancing Automated Decision-Making Through AI.* IGI Global; 2025; 67–96. <https://doi.org/10.4018/979-8-3693-6230-3.ch003>.
47. Sayyad. KK Approach to Increase Resilience in Internet of Things: A T-Cell Security Concept. In: Darwish D, Charan K, editors. *Analyzing Privacy and Security Difficulties in Social Media.* IGI Global; 2025; 87–120. <https://doi.org/10.4018/979-8-3693-9491-5.ch005>.
48. Sayyad. KK Approach for IoT Security: T-Cell Concept. In: Kumar R, Peng SL, Elngar A, editors. *Deep Learning Innovations for Securing Critical Infrastructures.* IGI Global Scientific Publishing; 2025.
49. Sayyad. Healthcare Monitoring System Driven by Machine Learning and Internet of Medical Things (MLIoMT). In: Kumar V, Katina P, Zhao J, editors. *Convergence of Internet of Medical Things (IoMT) and Generative AI.* IGI Global; 2025; 385–416. <https://doi.org/10.4018/979-8-3693-6180-1.ch016>.
50. Shinde SS, Nerkar PM, Kazi SS, Kazi VS. Machine Learning for Brand Protection: A Review of a Proactive Defense Mechanism. In: Khan M, Amin Ul Haq M, editors. *Avoiding Ad Fraud and Supporting Brand Safety.* IGI Global; 2025; 175–220. <https://doi.org/10.4018/979-8-3693-7041-4.ch007>.
51. Upadhyaya AN, Surekha C, Malathi P, Suresh G, Suriyan K, Liyakat KKS. Pioneering cognitive computing for transformative healthcare innovations. *SSRN Electron J.* 2025. <https://doi.org/10.2139/ssrn.5086894>.
52. Kutubuddin KSK. Approach in LOVE Health: AI-Driven-IoT (AIIoT) based Decision Making System in LOVE Health for Loved One. *GRENZE Int J Eng Technol.* 2025; 11(1): 4628–35. Grenze ID: 01.GIJET.11.1.371_1.
53. Liyakat KKS. Multimedia Technology in Healthcare: A Study. *J Multimedia Technol Recent Adv.* 2025; 12(1): 23–9.
54. Liyakat KKS. TensorFlow-Based Big Data Analytics for IoT Networks: A Study. *Int J Data Struct Stud.* 2025; 3(1): 32–40.

55. Liyakat KKS. Brand Protection Using Machine Learning: A New Era. *E-Commerce Future Trends*. 2025; 12(1): 33–44.
56. Dhanve, Liyakat KKS. Machine Learning Forges a New Future for Metal Processing: A Study. *Int J Artif Intell Mech Eng*. 2025; 1(1): 1–12.
57. Liyakat KKS. e-Skin Applications in Healthcare and Robotics: A Study. *J Adv Robot*. 2025; 12(1): 13–21.
58. Liyakat KKS. Millimeter Wave in Internet of Things Connectivity: A Study. *Int J Wirel Secur Netw*. 2025; 3(1): 13–23.
59. Liyakat KKS. TensorFlow-Based Big Data Analytics for IoT Networks: A Study. *Int J Data Struct Stud*. 2025; 3(1): 31–8.
60. Liyakat KKS. Multimedia Technology in Healthcare: A Study. *J Multimedia Technol Recent Adv*. 2025; 12(1): 23–9.
61. Patil JM. Robotic Surgery using AI-Driven-IoT Based Decision Making for Safety: A Study. *Int J Artif Intell Things Commun Ind*. 2025; 1(1): 35–44.
62. Liyakat KKS. VHDL Programming for Secure True Random Number Generators in IoT Security. *Res Rev Electron Commun Eng*. 2025; 2(1): 38–47.
63. Liyakat KKS. E-Commerce and AI: Product Recommendation and Pricing. *J Artif Intell Res Adv*. 2025; 12(2): 44–52.
64. Kazi KS. AI-Driven-IoT (AIIoT)-Based Jawar Leaf Disease Detection: KSK Approach for Jawar Disease Detection. In: Bhatti U, Aamir M, Gulzar Y, Bazai SU, editors. *Modern Intelligent Techniques for Image Processing*. IGI Global Scientific Publishing; 2025; 439–72. <https://doi.org/10.4018/979-8-3693-9045-0.ch019>.
65. Kazi KS. AI-Powered-IoT (AIIoT)-Based Decision-Making System for BP-Patient Healthcare Monitoring: BP-Patient Health Monitoring Using KSK Approach. In: Lytras M, Alajlan S, editors. *Transforming Pharmaceutical Research With Artificial Intelligence*. IGI Global Scientific Publishing; 2025; 189–218. <https://doi.org/10.4018/979-8-3693-6270-9.ch007>.
66. Kazi KS. A Study on AI-Driven Internet of Battlefield Things (IoBT)-Based Decision Making: KSK Approach in IoBT. In: Tariq M, editor. *Merging Artificial Intelligence With the Internet of Things*. IGI Global Scientific Publishing; 2025; 203–38. <https://doi.org/10.4018/979-8-3693-8547-0.ch007>.
67. Kazi KS. KK Approach to Increase Resilience in Internet of Things: A T-Cell Security Concept. In: Almaiah M, Salloum S, editors. *Cryptography, Biometrics, and Anonymity in Cybersecurity Management*. IGI Global Scientific Publishing; 2025; 199–228. <https://doi.org/10.4018/979-8-3693-8014-7.ch010>.