

Study of a Mist Enhanced Evaporative Cooler

Kunal Kumar¹, Rone^{2*}, Manish Kumar³

Abstract

Comfort air conditioning through vapour-compression refrigeration is commonly used and is the energy-intensive system. That to split air conditioning system is being employed to create cooling in closed spaces which lag in fresh air supply leading to an increase in carbon dioxide concentration in the cooled space. This is of very much concern towards to maintain indoor air quality. Evaporative Cooling (or Desert Cooling) concept is also a known phenomenon to generate cold by the evaporation of water; however, Flash Evaporation is the new concept which helps to evaporate the water particle generated through mist nozzle. To achieve the flash evaporation process, water is forced through a very small but specially designed nozzle and spinning disc leading to a very fine water mist i.e. Water droplets less than 50 microns. A mist nozzle and a spinning disc are the two innovative components lead to generate the fine mist at minimum cost and zero energy consumption. Which extend the benefits like less energy consumption, no maintenance, and no storage of water which actually promotes the fungus and mosquito breeding, no use of honeycomb structure, jute fiber or any cooling media as used in conventional desert coolers. As a result, it has no greenhouse gas impact and works as a green air cooler. Flash evaporative cooling systems consume @30 % less energy compared to the conventional evaporative cooling system. Subsequently, the use of such systems definitely leads to saving the building energy consumption. Also, the water consumption is just @ 1 liter per hour, and for mist generation no need of any high-pressure pump.

Keywords: Comfort cooling system, air conditioning system, mist chamber, mist spray direct evaporative cooler, axial fan

INTRODUCTION

In earlier days before the development of heating ventilation and air conditioning systems natural available resources were used for getting relief from heat stress such as-natural ventilation, shading. For example, the people an ancient conditioned their residences by using the evaporative cooling. Ancient people would sling wet clothes or grass mats on the wind-area side of their residence to get relief from the heat stress. Since 1900's people moved towards newly invented mechanical cooling systems [1–3].

*Author for Correspondence

Rone

E-mail: roniesomadder@gmail.com

¹Research Scholar, Department of Mechanical Engineering, FCEM, Faridabad, India

^{2,3}Assistant Professor, Department of Mechanical Engineering, FCEM, Faridabad, India

Received Date: December 04, 2025

Accepted Date: December 05, 2025

Published Date: December 22, 2025

Citation: Kunal Kumar, Rone, Manish Kumar. Study of a Mist Enhanced Evaporative Cooler. Journal of Refrigeration, Air Conditioning, Heating and Ventilation. 2025; 12(3): 01–13p.

Thermal Comfort

The ambient factors are as shown in Figure 1. It is made up of the radiant temperature, or the ambient air temperature, and relative humidity, which is the ratio of the quantity of moisture in the air. to the maximum amount that the air might hold at the same temperature.

The personal factors consist of metabolic rate of the human body to generate the heat and the clothing insulation wearied by the human being as represented in Figure 2.

From the theoretical point of view the most accepted definition is given by the American Society of Heating, Refrigeration and Air Conditioning Engineers (ASHRAE) which states: It is a condition of mind, which expresses satisfaction with the thermal environment. The figure 3 shows the major factors they are variables and few of them are not under human control like ambient air temperature and relative humidity and few of them are under control of the human being like clothing insulation, radiant temperature, air movement, and metabolic rate [4–7].

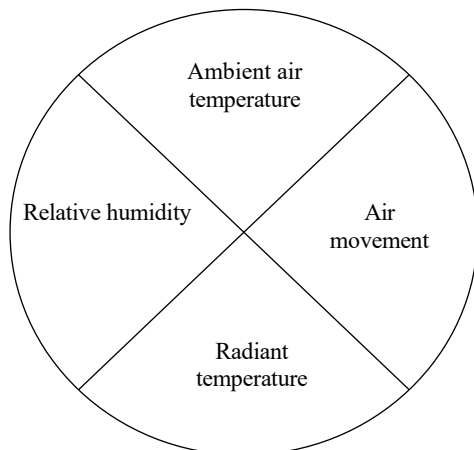

Figure 1. Ambient factors affecting thermal comfort.

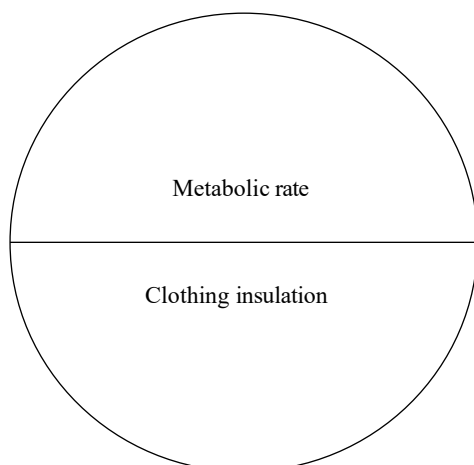

Figure 2. Personal factors affecting thermal comfort.

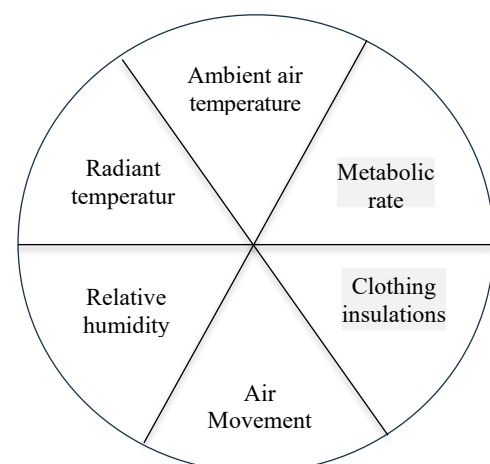

Figure 3. Factors affecting on thermal comfort.

Comfort Cooling System

Heat continually moves from an area with a high temperature to one at a low temperature. In hot days, outside hot air continuously flow in the buildings that have a low temperature. To maintain the thermal comfort inside the room, this additional heat must be removed from the room.

In cold days, continuous heat loss will take place from the room to the outside of the room. To maintain the thermal comfort inside the room, continuously heat must be provided to the air inside the rooms. The system which provides the heat required for thermal comfort is called a heating system

Air Conditioning System

An air conditioning system is a device which provides the thermal comfort conditions inside the room in hot as well as on cold days. Additionally, this technology oxygenates the air and keeps the room's humidity levels stable. An air conditioning process is the modification or changing of air characteristics (temperature, humidity, pressure, etc.) to comfortable levels with the goal of carrying the conditioned air to an inhabited space while improving thermal and indoor air quality.

The size of the system varies from a small portable unit to a hugely complex system; even so, the basic principals are the same. The air conditioning systems are having the major components are

- *Evaporator*: An element can takes heat out of the atmosphere or water.
- *Compressor*: A device used to compress and circulate the working substance in the system.
- *Condenser*: An element used to change the phase of the working substance by exchanging the heat.
- *Expansion Valve*: A device used to reduce the pressure and control the flow of the working substance.
- *Fan or Blower*: A device is used for moving the air.
- *Air Distribution System*: It is a network of pipe or ducting system to carry the air to the space to be cooled or heated. Other elements include the control systems, valves, safety cut off valves, dampers insulation, and devices used for reduction for vibration and sound level. The vapour contraction cycle is mostly used by conditioning systems.. The working substance used in the system is R22 or R410A. The air conditioning systems are having lots of residential, commercial and industrial applications to maintain the comfort conditions as per the requirement. In residential building, the air conditioning system is one of the major energy consuming elements; about 40% of the total energy consumed in the residential building is contributed by the air conditioning system [8].

Evaporative Air Cooling System

Water evaporation is nature's most inventive way to achieve cooling. The idea behind evaporative cooling is that heat is taken up by the evaporation of moisture. It also arises on human skin, causing perspiration and a drop in body temperature. This procedure is comparable to how a river's breeze makes you feel colder.

Elements determining the Rate of Evaporation

1. *Water availability*: Over the seas, the rate of evaporation will be greater than over the continents.
2. *Temperature*: The air's ability to retain moisture expands with temperature. The temperature of the water near the evaporation source rises with any increase in air temperature, giving the particles of water more energy to transition from a liquid to a gaseous form. As a result, the degree of heat of the evaporating surface directly affects evaporation. The rate of evaporation increases with the temperature of the evaporation surface.
3. *Relative Humidity*: The relative humidity of the air has had an immediate impact on the rate of evaporation. The rate of evaporation falls with increasing vapour pressure.

LITERATURE REVIEW

Evaporative cooling process has an existence since the earth has water on its surface in the form of ocean, lake, streams or ponds. Evaporative cooling is a natural process of cooling by exchanging the heat between the unsaturated hot and dry air and the water which comes in contact with each other. For example near the lakes, waterfalls, oceans, in particular, wet surfaces.

The greatest shift occurred in the first half of the nineteenth century as a result of the widespread usage of lighting. At the beginning of the air cooler design, air is forced through the wet cloth attached to the wooden frame. Water is kept moving on the cloth by adding sump and water circulating pump. This arrangement becomes the foundation for machines which is known by different names, from wet box to drip cooler and desert coolers to swamp coolers [9, 10].

EXPERIMENTAL TEST FACILITY AND PROCEDURE

This chapter describes the experimental test facility designed, developed and fabricated to evaluate the performance of a mist spray direct evaporative cooler (MSDEC). The details about the development of each part and its function in the test setup are described. The experimental procedure adopted during the experimental operation is explained. Firstly the performance measuring parameters like a drop in temperature, saturation efficiency, cooling capacity, the coefficient of performance, etc. are evaluated by modulating one of the performances regulating parameter and keeping other parameters constant. The mass flow rate of air, the mass flow rate of water, spinning disc diameter, Fin density projected on the spinning disc, Number of fan blades, etc are the performance regulating parameters are used. Secondly, the instruments used, measurements are taken are recorded in the tables and the results are plotted. Finally, the calculation procedure for obtaining uncertainties of various parameters is described and on the basis of the experimental data obtained an empirical correlation is developed by regression analysis to predict the drop in temperature [11].

Experimental Test Facility

Figure 4 shows a schematic diagram of an experimental facility developed. The test facility is an evaporative cooler with necessary measuring instrumentation. As mentioned in the research objective a mist spray direct evaporative cooler is developed. This test facility consists of an air filter, fan blade and spinning disc assembly, mist nozzle, air damper, air properties measuring sensors, supply water storage tank, water drain tray, and data acquisition system. The subsequent paragraphs provide the specifics of each element. Appendix 2 gives the detailed part drawings and the assembly drawing of the test facility.

Fan

A mechanical device commonly used to distribute the air for ventilation, material handling, refrigeration, cooling applications, dust collection, and others. Axial fans and centrifugal units are the two broad kinds of fans.

Axial fan

In an axial fan, air is pulled along the axis and blown along the axis of the fan shaft. The air is pressurized by the aerodynamic lift generated by the fan blades. Generally, axial fans are used in low pressure and high volume clean air applications [12].

Basically, the fan is required for two purposes:

1. To overcome the resistance due to friction to air flow.
2. To distribute the air to the space to be conditioned.

Therefore, the energy in the form of pressure must be supplied to the air. This is achieved by the rotating fan impeller, which exerts a force on the air, resulting in both flow of the air and increase in its pressure.

Air is drawn apart the fan shaft and expelled out from it in a fan that uses centrifugal force. In centrifugal fan with the help of kinetic energy of the impeller blades speed and volume of an air stream is increased. Typically, a scroll casing takes the air and concentrates it in a single path.

There are three types of axial fans are as follows:

1. Propeller Fan
2. Tube axial fan
3. Vane axial fans

Propeller Fan

Low pressure and high rates of airflow are produced by the propellers of fans. These fans are not suitable for airflow through the ducts. The efficiency is very low but they are inexpensive. The power consumption of propeller fans decreases with increasing airflow. They are repeatedly used in rooftop ventilation applications Figure 5 and Figure 6 show the schematic block diagram and the performance curve of the propeller fan respectively [13–15].

Tube Axial Fan

Applications requiring high rates of air flow and mild pressure employ tube axial fans. This fan generates greater pressures and better working economies than propeller fans. Because of the minimal rotational mass, the rated speed may be reached very quickly. The tube axial fans generate moderate airflow noise. The schematic diagram and performance curve diagram of the tube axial fans are as shown in Figure 7 and Figure 8 respectively [16].

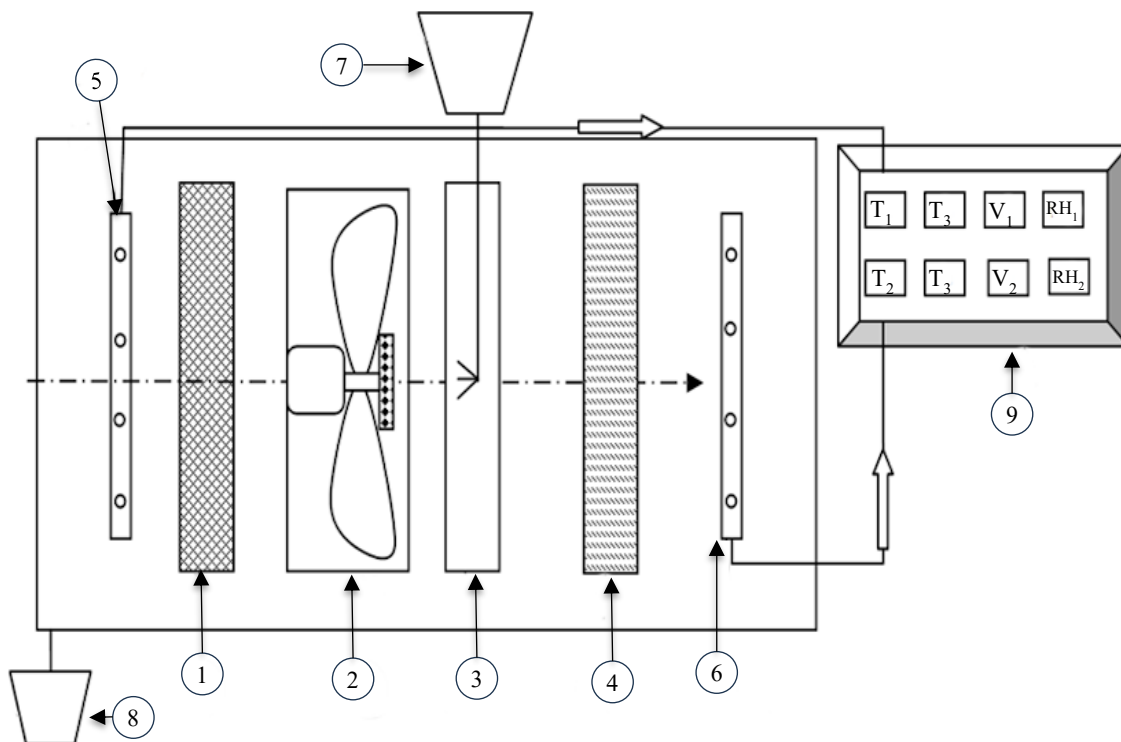

- | | |
|--|---|
| 1 Air filter | 6 Outlet air properties measuring sensors |
| 2 Fan and spinning disc assembly | 7 Water tank |
| 3 Mist nozzle | 8 Drain water tank |
| 4 Air damper | 9 Data acquisition system |
| 5 Inlet air properties measuring sensors | |

Figure 4. Schematic diagram of the test setup.

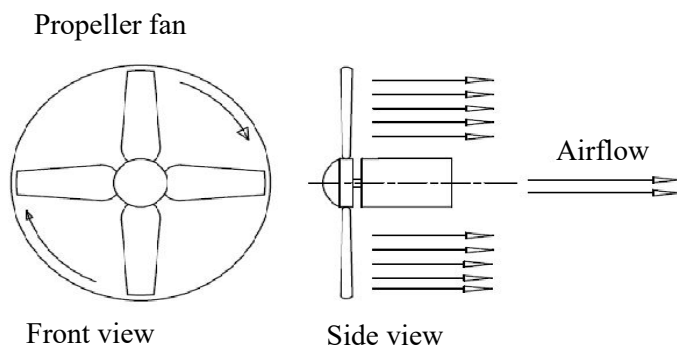

Figure 5. Block diagram of the propeller fan [ITS 08].

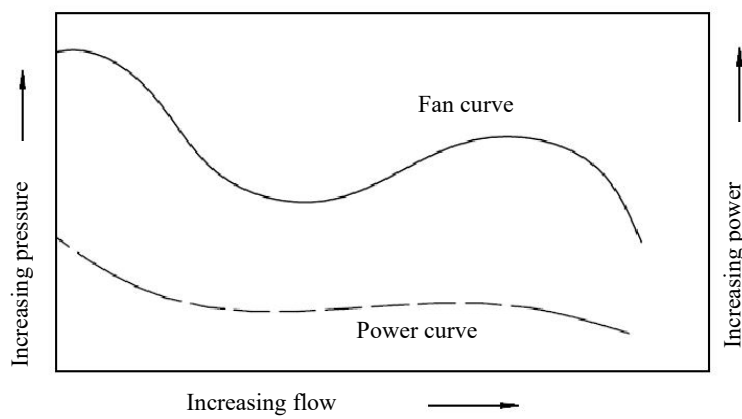

Figure 6. Performance curve of the propeller fan [ITS 08].

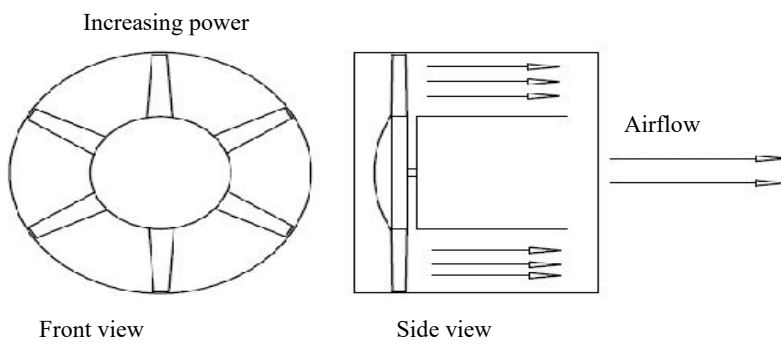

Figure 7. Schematic of tube axial fan [ITS 08].

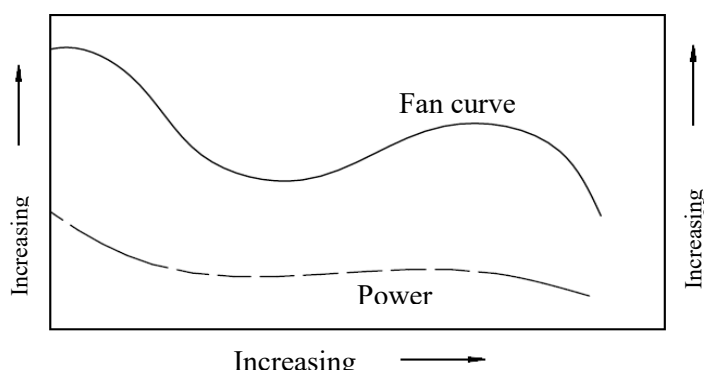

Figure 8. Performance curve of the tube axial fan [ITS 08].

Vane Axial Fan

In essence, the vane axial fan is a tube vertical fan with output vanes that are used to both straighten the airflow and turn the kinetic energy of the airstream into stationary pressure. Figure 9 and Figure 10 shows the two views of the vane-axial fan and its performance curve respectively [17–20].

The airflow profiles remain uniform. The tube axial fans are highly efficient when the equipped with airfoil blades built with a small clearance. The efficiency can be achieved by up to 85%. These types of fans are directly attached to the motor shafts.

This fan can be used for medium to high-pressure applications. It can be used in emergency ventilation. It achieves the operating speed relatively quickly as its low mass allows it to do so.

Methods of Mist Spray Generation

Basically, there are two methods are in practice to generate the mist spray as;

1. Mechanical Method
2. Thermal Method.

Mechanical Method

In this method, the mist spray is generated by using some mechanical means For example

- *Air-liquid mixing chambers (turbulence chamber):* Water/Insecticide and air are mixed together under pressure in a chamber to produce atomization. The mixture is delivered to the outside air through single or multiple nozzles. The pressure generated by a blower or compressor may deliver air at high volume and low pressure, or high pressure and low volume, depending on equipment design. Dispersal units are powered by electric or gasoline engines. These devices have the greatest versatility in the selection of air and liquid pressures or flow rates to facilitate liquid breakup and control particle size [21–25].

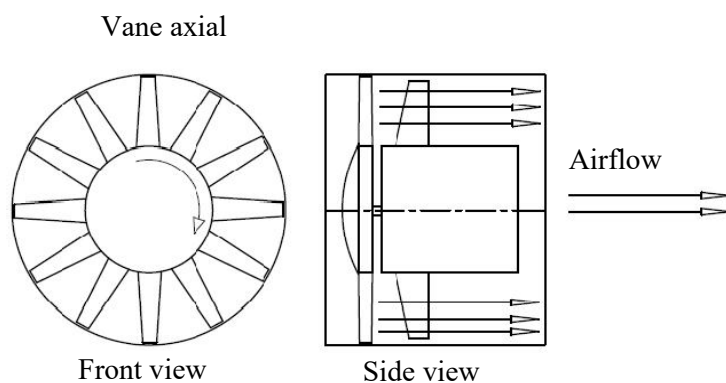

Figure 9. Orthographic views of the vane-axial fan [IT].

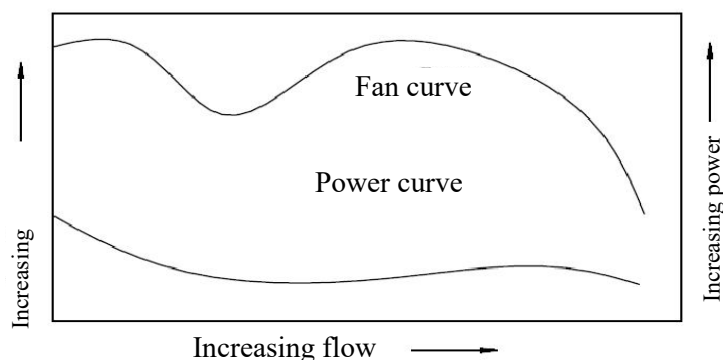

Figure 10. Performance curve of the vane-axial fan [ITS 08].

- *Rotating Sleeves Method:* Water/Insecticide under pump pressure is introduced into a rotating porous cylindrical sleeve, forcing the liquid through minute openings to produce atomization. Droplet size may be controlled by the porosity of the sleeve and by varying the insecticide pressure and flow rate. The breakup of the liquid may be further enhanced by air delivered from a fan producing a shearing action on the droplets. These units are usually electrically powered by 12-volt storage battery systems; sleeves and pumps are driven by electric motors.
- *Rotating discs method:* Water/Insecticide breakup is accomplished by introducing the liquid by gravity or pressure onto a motor-driven, cylindrically shaped disc rotated at high speed. The insecticide impinging on the disc is propelled outward to provide initial breakup. Shear produced by a motor-operated fan produces atomization. These devices may be hand-held or portable and are powered by batteries.

Thermal Method

Basically, in this method, thermal energy is used to generate the mist of water particles. For example;

- *Rotating disc:* In the rotating disc type, the water/insecticide is drawn between rotating discs, heated and forced into the exhaust system. The insecticide-fuel oil mixture is vaporized at a relatively high temperature (generally $>100^{\circ}\text{C}$) in the exhaust port and forced into a relatively low atmospheric temperature where condensation (= fog) occurs. The heat chamber type also disperses an insecticide fuel oil mixture.
- *Heat chamber (e.g., pulse jet):* In this method, a standard insecticide pump is used to shunt the material into a "heating chamber" where vaporization occurs. A Roots blower is used to force the vaporized material into the adjacent atmosphere, which drives the condensation.

There are several brands/models available for each method described above. Generally, each equipment company develops its own proprietary nozzle design to ensure the company's uniqueness.

Water Misting through the Nozzle

Traditionally, air atomizing or contact designs have been used by fine mist spray nozzles to create tiny droplets. To create the spray, impingement merely directs the fluid flow via a port onto a pin. One of the main drawbacks of impingement design is that the target pin is hard to position and is at risk for breakage or misalignment, which eventually results in subpar performance. Additionally, a target pin might fall loose and cause harm downstream. The impingement nozzle's pin/orifice feature wear down with time, which can negatively impact the spray pattern and drop size. This is a further disadvantage.

Over the nozzle's lifetime. Other popular design type is air atomizing, which atomizes the fluid using a supply of pressurized air. The higher cost of supplying and maintaining the pressurized air source is just one of the key drawbacks of the air-atomizing structures.

A number of nozzles that use a rotational flow have been created as alternatives in light of the aforementioned. The fluid's pressure head gets converted into kinetic energy within the swirl chamber by swirling flow nozzles. The centrifugal force causes the released fluid to disintegrate up into droplets. The applicability of swirl flow nozzles has been limited by a number of factors, such as poor tolerance when machining the substance from which the nozzles are made; the quality of the spray pattern deteriorates as the swirl chamber's size decreases; clogging due to smaller dimensions; and the difficulty during handling and connecting small parts [26–28].

Mist Chamber

It is a region where the air stream and mist water particles come in contact with each other and exchange of heat takes place. It is manufactured from the PVC material. It becomes a casing to fan blade and spinning disc. It is developed by cutting the 20-liter plastic tub of appropriate size, as shown in Figure 11 & 12.

Air Filter

Air filters are used to ensure a healthy indoor quality in the space to be cooled. The ambient outside air will have dust particles, such dust particles must be filtered before taking the air into the space to be cooled. A Jute cotton cloth having the mesh-like structure is used as a filter. The hole size on the mesh is a square of 1 mm. The air filter is placed at the inlet end of the system Figure 13.

There are two broad categories of air filters.

A kind of mechanical air filter known a High-Efficiency Particulate Air (HEPA) filter works by pushing air through a thin mesh that collects hazardous pollutants including dust mites, dog and cat pollen, and tobacco smoke. It has a 99% effectiveness at removing for P.M., 2.5-micron particles. Particles as small as 0.02 microns can be eliminated by the modern HEPA filters Figure 14.

Carbon Filters: Using the process of chemical adsorption, carbon filtering uses a bed of activated carbon to remove the contaminants and impurities. Because each activated carbon particle contains a wide surface area, pollutants are exposed to the greatest amount of space achievable, resulting in purification. Installing an air filter is a prerequisite for breathing clean air and leading healthy lifestyles. To stay away from airborne diseases and lead a healthy lifestyle, this is the need of the hour Figure 15.

Water Supply System

Manually operated water supply system as shown in Figure 16 has a water storage tank, water filter, water flow control valve, and water supply pipe. The water storage tank is having a capacity of 5 liters. By gravitational force, water is supplied to the nozzle through the water supply pipe. A water flow control valve is provided to control the flow of water. A filter net represented in Figure 17 is provided in the water storage tank to restrict the dust particle in the water before supplying to the nozzle. The blowdown water is collected in the sump provided at the bottom of the system and this water can be collected in the storage tank again from the sump manually or by using the pump Figure 18, 19.



Figure 11. Mist chamber.



Figure 12. Set of mist chamber.



Figure 13. Jute cotton air filter



Figure 14. HEPA Filter.



Figure 15. Carbon Filter.

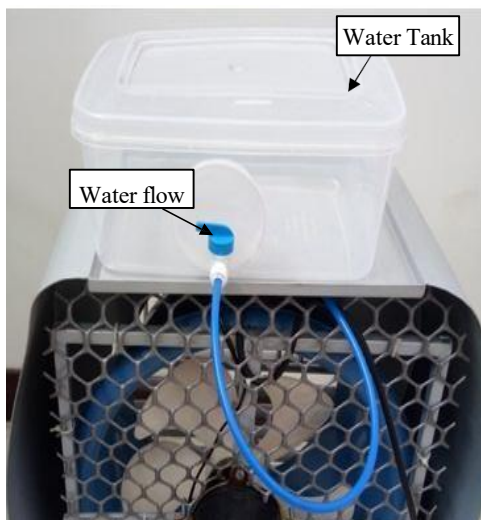

Figure 16. Water supply system.

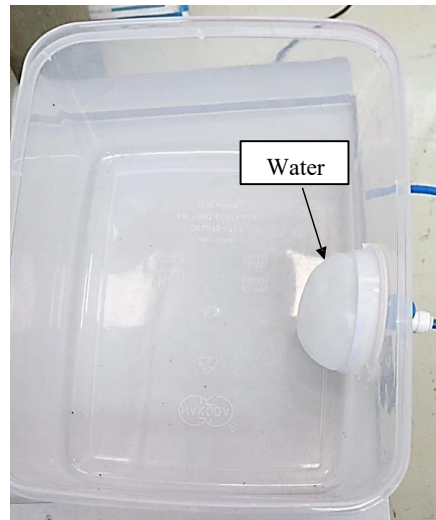

Figure 17. Water storage tank with filter.



Figure 18. Water supply pipe arrangement.

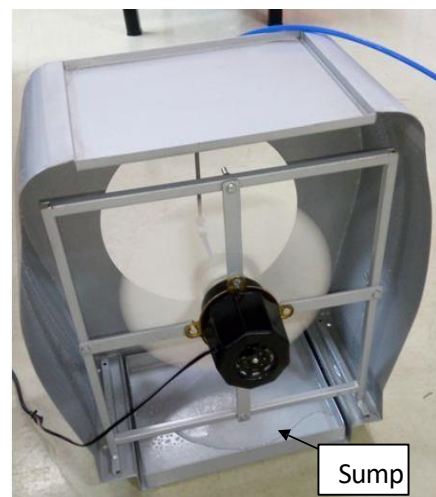

Figure 19. Drain water collection sump.

Components of Fan Speed and Water Flow Regulating System

In MSDEC a single phase ac motor is used to rotate fan blade. AC motor is preferred because we have single phase AC supply which is easily available for domestic appliances. To vary the fan speed and the water flow rate supplied to the MSDEC through the water flow control valve a remote controlled system is developed to provide the comfort cooling conditions. This system is developed using auto transformer, servo motor, an Arduino UNO kit.

CONCLUSIONS AND FUTURE SCOPE

A novel low-pressure nozzle, rolling disc, and axial fan are features of an innovation MSDEC. The mist is generated with the help of the mist nozzle and the spinning disc. The performance parameters say saturation efficiency and cooling capacity of MSDEC are obtained through experimentation.

Conclusions

- Saturation efficiency of the system is recorded up to 87% and the cooling capacity up to 3.5 kW.
- The COP of the system ranges from 20 to 45.
- It is also observed that the performance parameters are almost linearly varying with the mass flow rate of the air up to 0.5 kg/s, after this value, it starts to decrease.
- The spinning disc diameter affects the size of the droplet generation, the droplet size decreases with an increase in disc diameter. By observing practical limitations the spinning disc size is optimized 80 mm in diameter.
- The numbers of fins projected on the disc are 36 and are optimized by comparing the cooling effect produced by the system.
- The mass flow rate of water is optimized as 2.6 Lph and is achieved by using the nozzle. orifice diameter of 0.6mm. This value is fixed by taking care of saturation efficiency and the blow of water and cooling effect.
- The clearance between the tip of the fan blade and the casing is optimized experimentally as per the IS 3315 guidelines and by referring the guideline of BASF corporation of New Jersey of fan blade design. It is optimized as 5mm for the developed setup.
- Effect of a number of fan blades on the performance is tested and concluded to use 3 blades with the wide surface area. The maximum chord length is decided as 150mm the chord length at the hub is 50 mm.

This proposed MSDEC might be adjusted for numerous industrial purposes, particularly in the textile sector and in vegetable and fruit storage, where it is necessary to maintain an increased air humidity. Polyhouses can also employ air pre-coolers in air conditioning systems to regulate temperature as well as humidity.

An innovative MSDEC contains newly developed low-pressure nozzle, spinning disc, an axial fan. The mist is generated with the help of the mist nozzle and the spinning disc. The performance parameters say saturation efficiency and cooling capacity of MSDEC are obtained through experimentation. Thus, the cooling output is up to 3.5 kW and the air's immersion efficiency is up to 87%. The system's COP varies from 20 and 45. It is also observed that the performance parameters are almost linearly varying with the mass flow rate of the air up to 0.5 kg/s, after this value, it starts to decrease.

A fit regression model is used for developing an empirical correlation based on the data from the experiment. The predicted cooling air temperature by using the developed empirical equation and the experimental values of the cooled air temperature are in good agreement or more precisely they are in the order of $\pm 8\%$. This developed MSDEC could be modified for different industrial applications, especially where the higher humidity of air is required to be maintained such as textile industry, fruit and vegetable storages. Poly houses may also utilize air pre-cooling devices in air conditioning systems to regulate the temperature and humidity.

Future Scope

This work can be extended by putting the automation in controlling the mass flow rate of water with respect to the relative humidity requirement.

There is scope in the design of the fan blade by making the spinning disc is an integral part of the fan blade.

There is a very large scope in the design of the casing of an evaporative cooler.

REFERENCES

1. A. Berman., "Extending The Potential of Evaporative Cooling For Heat Stress Relief", *Journal of Dairy Science*, 89, 2006, pp 3817-3825. Principles Of Evaporative Cooling System (PDH Online Course Notes)
2. Andrei Hudson GuedesBarga, CleonildoSoares Braga., "Modeling of Cooling Evaporative System With Design And Comparison Between Drivers And Modern Classic Used In Climate of Environments", 22nd International Congress of Mechanical Engineering, 2013, pp 7182–7190.
3. Amrit Lal B., D.V. K. Samuel, Vimala B., "Evaporative Cooling System For Storage of Fruits and vegetables- A Review", *Journal of Food Science and Technology*, 50(3), 2013, pp- 429–442.
4. A. Fouda, Z. Melikyan., "A Simplified Model For Analysis of Heat and Mass Transfer In A Direct Evaporative Cooler", *Applied Thermal Engineering*, 31, 2011, pp 932–936.
5. Abdulrahman Th. Mohammad, Sohif Bin Mat, M.Y. Sulaiman, K. Sopian, Abduljalil A. Al-abidi., "Experimental Performance of a Direct Evaporative Cooler Operating in Kuala Lumpur", *International Journal of Thermal And Environmental Engineering*, 6(1), 2013, pp 15–20.
6. Halasz., "A general Mathematical Model of Evaporative Cooling Devices", *Rev, Gin Therm*, 37, 1998, pp 245–255.
7. B. Prinz, M. Bamberger., "Determination of Heat Transfer Coefficient of Air Mist Spray", *Material Science and Technology*, 5(4), 2013, pp 389–393.
8. B. Naticchia, M. D'Orazio, A. Carbonari, I. Persico., "Energy performance evaluation of a novel evaporative cooling technique", *Journal of Energy And Building*, 42, 2010, pp 1926–1938.
9. Bo Shen, Moonis R. Ally, C. Keith, William C. C., "Direct Evaporative Precooling Model and Analysis", *Oak Ridge National Laboratory/TM*, 231, 2010.
10. Brian C. Wilson, "Procedure for the Quantification of Evaporative Cooling Water Requirements", *Evaporative Cooling Water Requirements*, 1995.
11. Craig F., Lili Zhang, Jihui Y., Kazuo E., Ashraful M. A., Takeo Mizuno., "Measurement of The Evaporative Cooling Effect: Oscillating Misting Fan", *Building Research and Information*, *International Journal of Building Research And Information*, 2017.
12. Craig F., Masaki N., Masatoshi N. Minako N. Takeo M., "Study of Mist Cooling For Semi-Enclosed Spaces In Osaka", *Japan, Procedia Environmental Sciences*, 4, 2011, pp 228–238.
13. Chandrakant W, Satyashree G, ChaitanyaS., "A Review on Potential of Maisotsenko Cycle in Energy Saving Applications Using Evaporative Cooling", *International Journal of Advances Research in Sciences, Engineering and Technology*, 01(1), 2012, pp 15–20.
14. D. A. Hindoliya and C.S. Mullick., "Direct Evaporative Cooling for Thermal Comfort in a building in the summer Months for Four Climatic Zones of India", *Journal of The Solar Energy Society of India*, 14(1), 2004, pp 45–54.
15. Demis P., Sergey A., Pawel Drag., "Performance Comparison Between Selected Evaporative Air Coolers", *Energies* 2107, 10(577), 2017, pp 1–20.
16. Dipak A. W. , Samir J. D., Rasika D.D., "Technical Viability of Evaporative Cooling Systems for Human Thermal Comfort in Maharashtra", *International Journal of Innovative and Emerging Research in Engineering*, 2(4), 2015, pp 30–35.
17. E. Erell, Y. Etzion, D. Pearlmutter, R. Guetta, D. Pecomik., "A Novel multi- stage down –draft evaporative cool tower for space cooling. Part 1: Aerodynamic design", *International Conference “Passive And Low Energy Cooling For The Built Environment” 2005*, pp 521–528.
18. E. Velasco Gomez, F. C. Rey Martinez, A. Tejero Gonzalez., "The Phenomenon of Evaporative

- cooling from a humid surface as an alternative method for air – conditioning", *International Journal of Energy And Environment*, 1(1), 2010, pp 69–96.
19. E. Hajidavalloo, H. Eghtedari., "Performance Improvement of Air- Cooled Refrigeration System by Using Evaporatively Cooled Air Condenser", *International Journal of Refrigeration*, 33, 2010, pp 982–988.
 20. E. A. Awafo, K. A. Dzisi., "Appropriate Design of Evaporative Cooler for Mango Storage in the Transitional and Savannah Zones of Ghana", *International Journal of Engineering Sciences Research*, 3(2), 2012 pp 687–695.
 21. Hussain Y. M., Abduljaleel H. A., "Optimum Design of Evaporative Air Cooler", *Journal of Kerbala University*, 10, (2), 2012, pp 287–299.
 22. H. Montazeri, B. Blocken, J.L.M. Hensen., "Evaporative cooling by water spray systems: CFD simulation, experimental validation, and sensitivity analysis", *Journal of Building And Environment*, 2014, pp 1–13.
 23. Hideki Yamada, Gyuyoung Yoon, Masaya Okumiya, Hiroyasu Okuyama., "Study of Cooling system with Water Mist Sprayers: Fundamental Experimentation of Particle Size Distribution and Cooling Effects", *Building Simulation*, 2008.
 24. Huang X., Zhang Xu., "Experimental Study On Spray Cooling Performance of Pressure Atomizing Nozzle", *Transactions of Tianjin University*, 18(3), 2012, pp 231–236.
 25. Huang Xiaoqing, ZHANG Xu., " Experimental Study on Spray Cooling Performance of Pressure Atomizing Nozzle", *Trans. Tianjin University Volume 18*, 2012, pp 231–235
 26. Igor K., Maarten S., "The Numerical Model For Direct Evaporative Cooler", *Applied Thermal Engineering*, 2016, Accepted Manuscript.
 27. Ibrahim U. Haruna, Lateef L. Akintunji, Bello S. Momoh, Muhammad I. Tikau, "Theoretical Performance Analysis Of Direct Evaporative Cooler In Hot And Dry Climates", *International Journal Of Scientific And Technology Research*, 3(4), 2014, pp 193–197.
 28. Jay A. Bolt, Thomas A. Boyle., "Investigation of Means For Producing Fuel Sprays of Uniform Drop Size"ss In Air Washers"