

# A Review of Recent Advancements in The Field of Friction Stir Welding of Dissimilar Joints Made of Aluminium and Magnesium

P J Lokesh Kumar<sup>1\*</sup>, S Shankaranarayanan<sup>2</sup>, C Jayabalan<sup>3</sup>, S D Sekar<sup>4</sup>, K Sengottaiyan<sup>5</sup> and R Suresh Kumar<sup>6</sup>

## Abstract

*Friction stir welding (FSW) stands at the forefront of welding technology, offering a promising avenue for joining dissimilar metals like aluminum and magnesium. These metals, renowned for their exceptional properties such as ductility, thermal conductivity, low density, and impressive weight-to-strength ratios, find wide utility across numerous industrial sectors. However, traditional fusion welding methods often struggle to effectively join aluminum and magnesium due to their disparate physical and chemical characteristics. FSW circumvents these challenges by employing a solid-state welding approach, utilizing frictional heat generated between a rotating tool and the workpieces to create a robust bond without melting the metals. This method sidesteps common issues encountered in fusion welding, such as solidification cracking, porosity, and distortion. In the context of aluminum-magnesium joints, understanding and optimizing FSW process parameters are crucial for achieving desired mechanical properties and mitigating defects. This paper provides a comprehensive overview of FSW for joining aluminum to magnesium, delving into key aspects such as process parameters, mechanical properties of the joints, and common defects encountered during welding. By elucidating these critical factors, researchers and engineers can enhance the quality and reliability of FSW-produced aluminum-magnesium joints, thereby unlocking new possibilities for lightweight, high-performance structures in industries ranging from automotive and aerospace to marine and construction. As FSW technology continues to evolve, its potential for revolutionizing metal joining processes across diverse applications remains both compelling and exciting.*

### \*Author for Correspondence

P J Lokesh Kumar

<sup>1</sup>Assistant Professor, Department of Mechanical Engineering, R.M.K. Engineering College, India

<sup>2</sup>Assistant Professor, Department of Mechanical Engineering, Velammal Engineering College, India

<sup>3</sup>Assistant Professor, Department of Mechanical Engineering, AMET University, India

<sup>4</sup>Associate Professor, Department of Mechanical Engineering, R.M.K. Engineering College, India

<sup>5</sup>Assistant Professor, Department of Mechanical Engineering, R.M.K. Engineering College, India

<sup>6</sup>Professor, Department of Mechanical Engineering, R.M.K. Engineering College, India

Received Date: February 28, 2024

Accepted Date: March 07, 2024

Published Date: April 22, 2024

**Citation:** P J Lokesh Kumar, S Shankaranarayanan, C Jayabalan, S D Sekar, K Sengottaiyan, R Suresh Kumar. A Review of Recent Advancements in the Field of Friction Stir Welding of Dissimilar Joints Made of Aluminium and Magnesium. Journal of Polymer & Composites. 2024; 12 (Special Issue 1): S134–S142p

**Keywords:** Magnesium, aluminum, friction stir welding, solid state welding, welding defect

## INTRODUCTION

The study of welding materials that are not the same has become quite interesting to scientists and engineers. In many different industries, there is an ongoing need to create machine parts or structures that are lightweight, highly durable, have better electrical qualities, and are economical [1]. [2]. Additionally, the majority of the components must display several attributes, necessitating the fusion of various materials into a single component [3]. [4, 5]. More lightweight structures must be used in transportation vehicles if we want to lower carbon dioxide emissions and improve fuel economy. According to estimates, each 100 kg decrease in the total weight of the vehicle result in fuel savings of between 0.16 and 0.27 l/km and a 12.5 g/km

reduction in CO<sub>2</sub> emissions [6]. [7]. This can be done by switching out structures made of heavy materials (like steel) with ones built of relatively light materials (like aluminium, magnesium, and composites). Due to its high specific mechanical qualities, strong resistance to external atmospheric corrosion, and density that is almost one-third that of steel, aluminium and its alloys have replaced steel as the material of choice. On the other hand, due to its high damping coefficient, superior shock absorption, high corrosion resistance, and recyclable nature, magnesium and its alloys, which have a density one-fourth that of steel, have also attracted a lot of interest. Their hybrid components and structures have a wide range of industrial applications because they can mix the properties of the two metals and utilize all of their benefits simultaneously. Table 1 shows certain metals' physical characteristics.

**Table 1.** The physical characteristics of magnesium and aluminium

Physical Characteristics	Aluminium	Magnesium
Density [g/cm <sup>3</sup> ]	2.71	1.8
Ultimate Tensile Strength [MPa]	290	280
Yield Strength [MPa]	240	145
Young's Modulus of Elasticity [GPa]	69	45
Melting Point [°C]	600	550-640
Thermal Conductivity [W/(m.K)]	150	116

The aforementioned negative consequences could be reduced by solid-state welding to join aluminium and magnesium. Welding by friction stir (FSW) was initially recommended in 1991 by the Welding Institute. FSW has shown a lot of promise for combining both similar and unrelated materials [8]. [9]. A non-consumable spinning metal contact deforms plastically because of the heat produced by friction from the tool, which mixes the components of the work piece and has various advantages over traditional joining methods for creating connections. In Figure 1. the FSW basic schematic is illustrated [10]. & Figure. 2 shows the Industrial application of FSW [8].

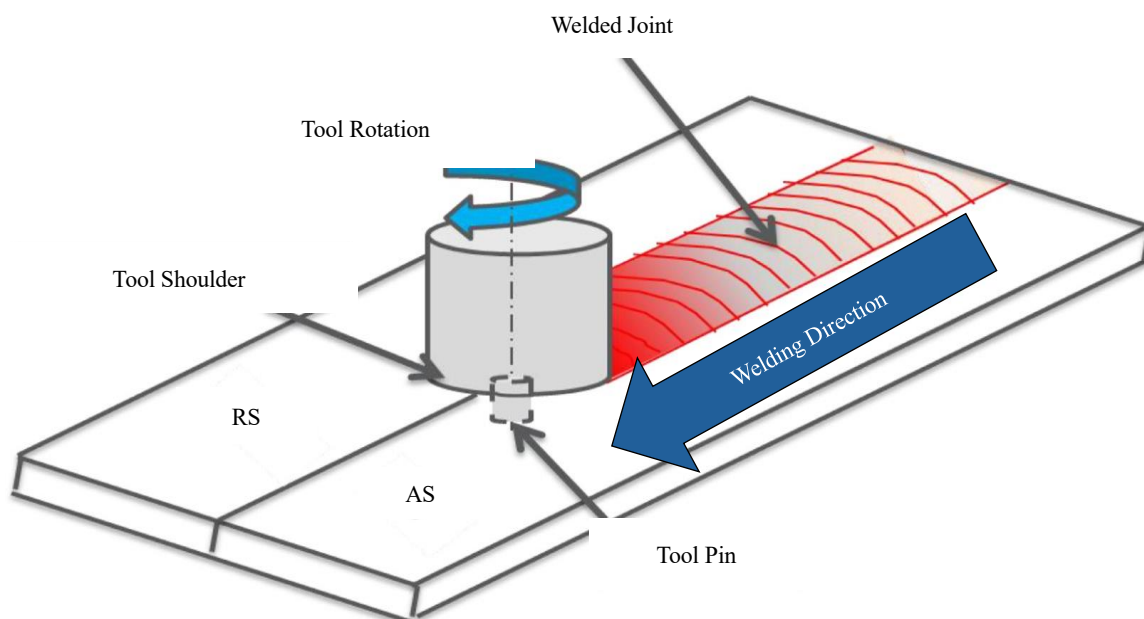

**Figure 1.** Diagrammatic illustration of the FSW procedure [10].

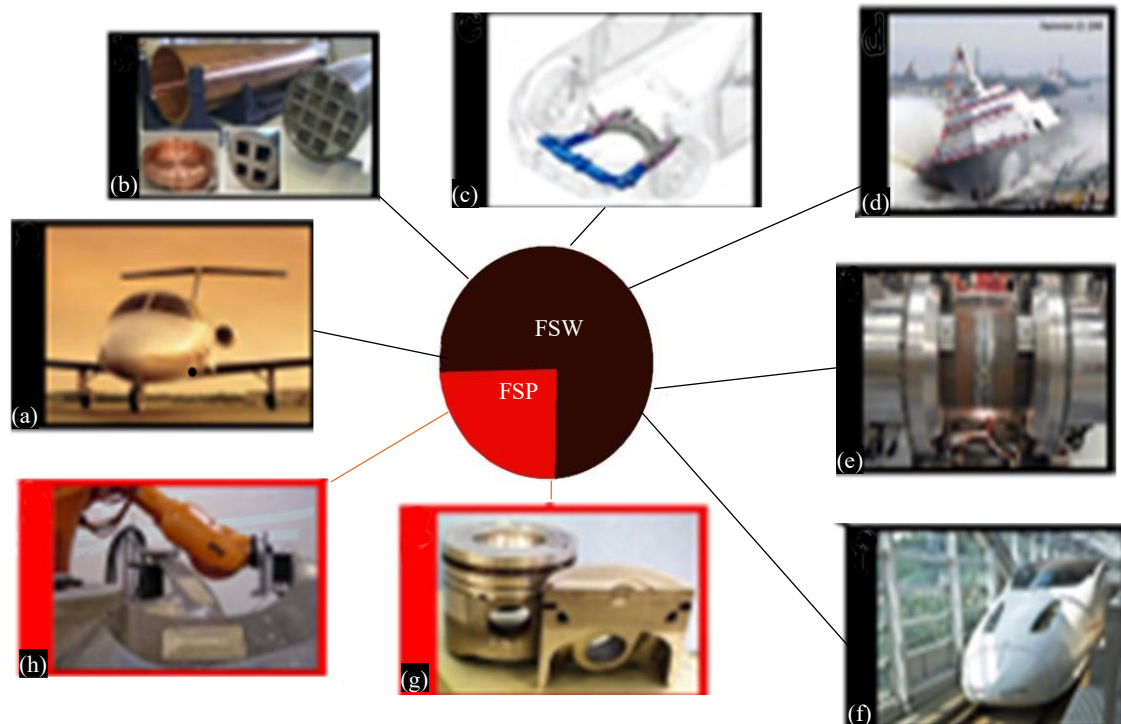

**Figure 2.** Industrial application of FSW [8].

### **AL-MG JOINTS' PROCESS PARAMETER FOR FSW**

It is crucial to fully comprehend how several FSW factors, including the FSW tool, insertion of tool depth, tool tilt angle, speed of welding, and rotation speed, affect the characteristics of the welded connection. To produce a high-quality, defect-free weld utilising FSW, these key process variables must be thoroughly examined. Researchers have run an abundance of experiments to investigate how each FSW parameter affects the look of the weld, the weld area microstructure, as well as its electrical and thermal attributes, and above all, the durability of the joint [11].

In the scenario of different FSW of copper and aluminium, carefully choosing the right operational set of process variables is necessary to allow proper material flows in the horizontal as well as the vertical orientations within the area of stir, provide satisfactory heating and softening of the work piece, and ultimately result in a high- superior weld joint across two different metals. The primary characteristics for the procedure that are used to FSW-weld magnesium and aluminium are listed below, along with an explanation of how they impact the joint properties.

### **FSW Tool For Al - Mg Joining**

The shoulder and pin-shaped welding tool is crucial to the FSW procedure. The characteristics of the joint are impacted by the FSW tool's impact on the movement of materials and heat generation during the FSW operation [12]. [13]. Consequently, improved FSW enactment, an extended range of FSW process settings, enhanced Al-Mg FSW integration are all facilitated by efficient FSW tool design. As a result, for FSW of various Al and Mg, the substantial used for the tool and its inherent qualities are vital factors.

### ***Instrumentation for FSW of Al and Mg***

Throughout the FSW procedure, the tool's geometry and characteristics must remain constant. The tool substantial must possess the following qualities in order to produce effective welds: hot hardness,

uniform microstructure, durability, fracture hardness, machining ease, tool reactivity, and sufficient density [14]. [15]. Table 2 [14]. is a list of the welding tool materials of various base materials.

**Table 2.** Tool components and applications [14].

Base material	Thickness (mm)	Tool material
Aluminium and its alloy	<12	Tool steel, tungsten carbide
Magnesium and its alloy	<6	Tool steel, tungsten carbide
Copper and its alloy	<50	PCBN, tungsten alloy
Titanium alloy	<6	Tungsten alloy
Stainless steel	<6	PCBN, tungsten alloy
Nickel alloy	<6	PCBN

With the use of treated HSS and tool steels that range in inflexibility is about hardened 45 HRC to 62 HRC, numerous studies have successfully conducted dissimilar FSW on AlCu [16]. [17]. Although tool has been the material of choice for research on AlCu FSW, these tools deteriorate and wear out faster with strong rubbing action generated by the Cu and Al alloy. The main factors contributing to tool deterioration are the tool steel's inadequate temperature stability and wear increased levels of tolerance rotating speeds [18]. [19]. The instruments materials should be selected taking into account the properties of the base, the different materials being connected, as well as their thickness [20].

### Friction Stir Welding Tool Geometry

The welder tool affects the heat produced, the flow of plasticized experienced material, force, and torque during joining should be properly planned and developed. [21]. Critical features are the diameters, surface profiles, pin and shoulder geometry [22]. The generation of heat during FSW is greatly influenced by the shoulder diameter and its surface profile, which raises the highest temperature. [23]. [24]. Rendering the tool's surface and shoulder diameter in relation to the study properties have a significant impact on the heat produced by rubbing between the work piece and shoulder surface, and that in turn affects joint properties and the production of defects [25]. [26]. [27].

During welding, the tool's protruded component that is axially introduced into the workpiece is called the probe. Extruded material was forged behind the tool due to the movement of the tooling pin inside the workpiece. Critical parameters of the tool pin include its pin surface, diameter, and length contour [28]. [29]. [30]. [31]. However, none of the three welding methods depicted in Figure 3 significantly changed the joint's micro hardness.

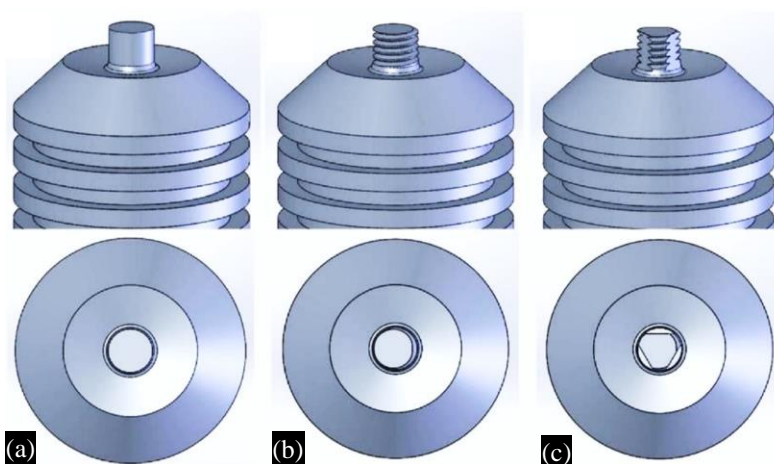

**Figure 3.** Demonstration of a welding instrument with a modified three types of pin form: (a) threaded, (b) featureless, and (c) threaded with flutes [32].

### ***Impact of Welding Speed on Al - Mg FSW***

Speed of welding is the rate of translational movement of the instrument along the joint's weld line. It's among the essential factors that regulates how much the work pieces are heated throughout the welding. The welding speed and input heat are inversely proportional. In other words, the FSW method produces more heat when welding at a low speed than when welding at a fast speed. Jayabalan and Muthu investigated the impacts of welding speed on Al-Cu joints' microstructure created by FSW [33]. The breaking strength of AlCu joints was found to be enhanced by raising the rate of welding from 50 mm/min to 80 mm/min, according to the study. The possibility of making flawless joints increases when moderate welding speed and high heat input lead to improved plastic conveyance of material, hence reducing flow stress.

### **Impact of Tool Rotation Speed on Al-Mg FSW**

Another crucial process variable that has a substantial impact on the temperature react during different FSW is the tool rotational speed. The tool's rotation about its axis influences the development of frictional heat that leads to plastic deformation and generates enough axial force to have an impact on material flow, lump zone size, and most significantly the formation of IMCs.

The ideal series of rotating and welding rapidity for Al-mg FSW is still up for debate since both tremendously low and tremendously high fusing temperatures, it controls both parameters, are problematic, frequently lead to unsatisfactory joint characteristics. The ideal mix of both parameters must also be found because speed of rotation and speed of welding are crucial in regulating the heat source used in the FSW procedure.

### ***Tool Pin Insertion Depth's Impact on Al - Mg FSW***

One of the crucial factors for assuring an enhanced weld quality has been determined to be the tool pin tip's length of penetration into the bottom of the metal plate surface is known as the pin implantation depth in FSW [34]. [35]. Using FSW to evaluate the impact depth of implantation on the calibre of the lap joint in magnesium alloys, it was found that extending the length of tool pin and depth of penetrating increased the joint's strength against shear into the bottom sheet [36].

However, the pin's forceful contact with the inflexible sheet metal and its motion at the vicinity of the welded junction enhance the likelihood wear and tear on tools. To avoid significant pin wear, Guan et al. used a rapid rate of rotation technique to create AlCu Friction Stir Welded lap joints without the lower copper plate being penetrated by a tool [37]. Al - Mg joints worked successfully, and FSW was carried out with only minimal tool - work piece interaction. High speed of rotation joints also shown increased fracture resistance. The extremely high temperature of reaction from above to below the pin, allowing for enough material mixing to strengthen the interface connection, was mostly attributed.

## **THE MECHANICAL CHARACTERISTICS OF AL-MG DISSIMILAR JOINTS' FSW**

Its hardness and tensile strength define how effective the FSW joint is. The relative distribution of both strength and hardness of Al-Mg FSW joints will be investigated in order to demonstrate the welding mechanisms and verify investigations of the method of welding and microstructure characterization. As a result, welding procedures may be designed for improved joint characteristics.

### **FSW Dissimilar Joints' Tensile Strength**

In many applications, the most crucial characteristic that distinguishes an excellent joint from one that is poor is its mechanical strength. If the subject matter has the FSW arrangement, then this is theoretically feasible. In an extra attempt to boost strength, Hou et al. used the cold spraying Ni bilayer in the pure copper plates of the AA6061-T6 alloy and the FSW of C11000 [17]. They discovered that the tensile strength of welds with a Ni interlayer is 190 MPa, which is 25% higher than that of welds without one. There was a 91% increase in strain from 5.5% in the case of the joint without a Ni bilayer and 10.5% in the case of one. The Ni interlayer's activity directs the fracture route originating from the interface through the area wherein Ni particles are most abundant, improving both ductility and strength.

### ***FSW Different Joints' Hardness***

Material movement and welding temperatures can affect joint hardness [38]. Additionally, the dispersion of hardness during Al-Mg FSW is impacted by broken-up magnesium particles in the Al matrix. Production of Al and Mg IMCs together, the value of hardness can be further improved. The SZ has the maximum hardness due to mechanical twinning, dynamic recrystallization, grain refining and strengthening of solid solutions.

### **WELDING IMPERFECTION IN THE AL-MG DISSIMILAR FSW JOINING**

Given the difficulty of FSW of various materials, it is challenging to watch the formation of the onion rings structure and, moreover, to describe the discrete weld zone [39]. Considering how drastically different their mechanical in nature, physical in nature, thermal processing, and electrical characteristics are greater dependence at high joining temperatures, it can be observed that combining Al and Cu is difficult. FSW was discovered to have a greater influence on reducing flaws and offering a solid union of dissimilar Al-Cu welding, but it still has flaws. In the nugget zone, brittle IMCs are more likely to form, and mechanical testing has shown that the joints typically fail. Finding the ideal FSW process parameters and choosing the right welding techniques are crucial in this regard since they significantly affect the weld joint's quality and flaw generation susceptibility. The foremost types of faults include a tunnel, keyhole, hollow and voids, fracture and weld thinning. It is crucial to remember that the primary causes of poor weld formation would be inappropriate base material interaction and significant intermetallic phase synthesis.

### **CONCLUSIONS**

A comprehensive analysis of the research on the different FSW of magnesium to aluminium that has already been published has been done in order to provide perception into the recently available cutting-edge information. The bulk of the research publications that were cited demonstrated a deep comprehension of the dissimilar FSW process parameters and how they affect the mechanical as well as microstructural characteristics of joints for Al and Mg. Other possible FSW modifications that researchers have used for Al - Mg with varying FSW are also indicated. The numerical simulation of FSW for Al and Mg is investigated to discover some advances in the study efforts and accomplishments to date, as well as its importance to identify development of microstructure and temperature. According to the literature currently accessible, the FSW temperature that is reached through the tool rotation and Speed at which we weld is a critical factor that must be controlled for the defect-free joining of Al and Mg. In addition, the standard of flawless FSW joints of Al-Mg is greatly influenced by the welding process, which includes base material location, tilt angle, plunge depth, and tool pin offset.

According to various experts, the friction stir welding procedure may successfully fuse materials made of magnesium and aluminium. The characteristics of Al-Mg junctions are significantly influenced by characteristics such as the welding speed, tool pin, and tool rotational speed insertion depth. For evaluating joint quality, tool geometry and materials are also crucial. A co-existence zone can be used to observe how successfully the two materials combined and how mechanical properties were affected. The inclusion of hooks may increase the mechanical strength in a lap layout.

### **REFERENCES**

1. M. R. Muhamad et al., Effects of Al-Ni powder addition on dissimilar friction stir welding between AA7075-T6 and 304 L, *Materwiss. Werksttech.*, vol. 51, no. 9, pp. 1274–1284, 2020, doi: 10.1002/mawe.201900105.
2. W. Zhang, Y. Shen, Y. Yan, R. Guo, W. Guan, and G. Guo, Microstructure characterization and mechanical behavior of dissimilar friction stir welded Al/Cu couple with different joint configurations, *Int. J. Adv. Manuf. Technol.*, vol. 94, no. 1–4, pp. 1021–1030, 2018, doi: 10.1007/s00170-017-0961-2.

3. M. R. bin Muhamad et al., Enhancements on dissimilar friction stir welding between AZ31 and SPHC mild steel with Al-Mg as powder additives, *J. Manuf. Sci. Eng. Trans. ASME*, vol. 143, no. 7, pp. 1–10, 2021, doi: 10.1115/1.4049745.
4. Y. Itoh, M. J. Bröcker, S. I. Sekine, D. Söll, and S. Yokoyama, Dimer-dimer interaction of the bacterial selenocysteine synthase sela promotes functional active-site formation and catalytic specificity, *J. Mol. Biol.*, vol. 426, no. 8, pp. 1723–1735, 2014, doi: 10.1016/j.jmb.2014.01.003.
5. T. A. Shehabeldeen, Y. Yin, X. Ji, X. Shen, Z. Zhang, and J. Zhou, Investigation of the microstructure, mechanical properties and fracture mechanisms of dissimilar friction stir welded aluminium/titanium joints, *J. Mater. Res. Technol.*, vol. 11, pp. 507–518, 2021, doi: 10.1016/j.jmrt.2021.01.026.
6. X. Cui, H. Zhang, S. Wang, L. Zhang, and J. Ko, Design of lightweight multi-material automotive bodies using new material performance indices of thin-walled beams for the material selection with crashworthiness consideration, *Mater. Des.*, vol. 32, no. 2, pp. 815–821, 2011, doi: 10.1016/j.matdes.2010.07.018.
7. E. Schubert, M. Klassen, I. Zerner, C. Walz, and G. Sepold, Light-weight structures produced by laser beam joining for future applications in automobile and aerospace industry, *J. Mater. Process. Technol.*, vol. 115, no. 1, pp. 2–8, 2001, doi: 10.1016/S0924-0136(01)00756-7.
8. A. Heidarzadeh et al., Friction stir welding/processing of metals and alloys: A comprehensive review on microstructural evolution, *Progress in Materials Science*, vol. 117. Elsevier Ltd, 2021. doi: 10.1016/j.pmatsci.2020.100752.
9. V. P. Singh, S. K. Patel, A. Ranjan, and B. Kuriachen, Recent research progress in solid state friction-stir welding of aluminium–magnesium alloys: A critical review, *J. Mater. Res. Technol.*, vol. 9, no. 3, pp. 6217–6256, 2020, doi: 10.1016/j.jmrt.2020.01.008.
10. M. M. El-Sayed, A. Y. Shash, M. Abd-Rabou, and M. G. ElSherbiny, Welding and processing of metallic materials by using friction stir technique: A review, *J. Adv. Join. Process.*, vol. 3, no. January, p. 100059, 2021, doi: 10.1016/j.jajp.2021.100059.
11. M. Verma, S. Ahmed, and P. Saha, Challenges, process requisites/inputs, mechanics and weld performance of dissimilar micro-friction stir welding (dissimilar  $\mu$ FSW): A comprehensive review, *J. Manuf. Process.*, vol. 68, no. PA, pp. 249–276, 2021, doi: 10.1016/j.jmapro.2021.05.045.
12. A. Banik, A. Saha, J. Deb Barma, U. Acharya, and S. C. Saha, Determination of best tool geometry for friction stir welding of AA 6061-T6 using hybrid PCA-TOPSIS optimization method, *Meas. J. Int. Meas. Confed.*, vol. 173, p. 108573, 2021, doi: 10.1016/j.measurement.2020.108573.
13. J. Li, Y. Shen, W. Hou, and Y. Qi, Friction stir welding of Ti-6Al-4V alloy: Friction tool, microstructure, and mechanical properties, *J. Manuf. Process.*, vol. 58, no. May, pp. 344–354, 2020, doi: 10.1016/j.jmapro.2020.08.025.
14. R. Rai, A. De, H. K. D. H. Bhadeshia, and T. DebRoy, Review: Friction stir welding tools, *Sci. Technol. Weld. Join.*, vol. 16, no. 4, pp. 325–342, 2011, doi: 10.1179/1362171811Y.0000000023.
15. H. Fujii, L. Cui, M. Maeda, and K. Nogi, Effect of tool shape on mechanical properties and microstructure of friction stir welded aluminum alloys, *Mater. Sci. Eng. A*, vol. 419, no. 1–2, pp. 25–31, 2006, doi: 10.1016/j.msea.2005.11.045.
16. P. Xue, D. R. Ni, D. Wang, B. L. Xiao, and Z. Y. Ma, Effect of friction stir welding parameters on the microstructure and mechanical properties of the dissimilar Al-Cu joints, *Mater. Sci. Eng. A*, vol. 528, no. 13–14, pp. 4683–4689, 2011, doi: 10.1016/j.msea.2011.02.067.
17. W. Hou et al., Enhancing metallurgical and mechanical properties of friction stir butt welded joints of Al–Cu via cold sprayed Ni interlayer, *Mater. Sci. Eng. A*, vol. 809, no. November 2020, p. 140992, 2021, doi: 10.1016/j.msea.2021.140992.
18. P. Mastanaiah, G. M. Reddy, and A. Sharma, Evolution and current practices in friction stir welding tool design. Elsevier Inc., 2021. doi: 10.1016/B978-0-12-822049-8.00006-2.
19. P. Sahlot and A. Arora, Numerical model for prediction of tool wear and worn-out pin profile during friction stir welding, *Wear*, vol. 408–409, pp. 96–107, 2018, doi: 10.1016/j.wear.2018.05.007.

20. Y. Du, T. Mukherjee, P. Mitra, and T. DebRoy, Machine learning based hierarchy of causative variables for tool failure in friction stir welding, *Acta Mater.*, vol. 192, pp. 67–77, 2020, doi: 10.1016/j.actamat.2020.03.047.
21. L. H. Shah, S. Walbridge, and A. Gerlich, Tool eccentricity in friction stir welding: A comprehensive review, *Sci. Technol. Weld. Join.*, vol. 24, no. 6, pp. 566–578, 2019, doi: 10.1080/13621718.2019.1573010.
22. X. Wang, Y. Pan, and D. A. Lados, Friction Stir Welding of Dissimilar Al/Al and Al/Non-Al Alloys: A Review, *Metall. Mater. Trans. B Process Metall. Mater. Process. Sci.*, vol. 49, no. 4, pp. 2097–2117, 2018, doi: 10.1007/s11663-018-1290-z.
23. C. Zhang, G. Huang, Y. Cao, Q. Li, L. Niu, and Q. Liu, Characterizations of microstructure, crystallographic texture and mechanical properties of dissimilar friction stir welding joints for AA2024 and AA7075 under different tool shoulder end profiles, *Mater. Today Commun.*, vol. 25, no. July, p. 101435, 2020, doi: 10.1016/j.mtcomm.2020.101435.
24. L. Shi, C. S. Wu, and L. Fu, Effects of tool shoulder size on the thermal process and material flow behaviors in ultrasonic vibration enhanced friction stir welding, *J. Manuf. Process.*, vol. 53, no. November 2019, pp. 69–83, 2020, doi: 10.1016/j.jmapro.2020.02.002.
25. L. Trueba, G. Heredia, D. Rybicki, and L. B. Johannes, Effect of tool shoulder features on defects and tensile properties of friction stir welded aluminum 6061-T6, *J. Mater. Process. Technol.*, vol. 219, pp. 271–277, 2015, doi: 10.1016/j.jmatprotec.2014.12.027.
26. Q. Chu, S. J. Hao, W. Y. Li, X. W. Yang, Y. F. Zou, and D. Wu, Impact of shoulder morphology on macrostructural forming and the texture development during probeless friction stir spot welding, *J. Mater. Res. Technol.*, vol. 12, pp. 2042–2054, 2021, doi: 10.1016/j.jmrt.2021.04.013.
27. K. K. MUGADA and K. ADEPU, Effect of knurling shoulder design with polygonal pins on material flow and mechanical properties during friction stir welding of Al–Mg–Si alloy, *Trans. Nonferrous Met. Soc. China (English Ed.)*, vol. 29, no. 11, pp. 2281–2289, 2019, doi: 10.1016/S1003-6326(19)65134-4.
28. A. Garg and A. Bhattacharya, Strength and failure analysis of similar and dissimilar friction stir spot welds: Influence of different tools and pin geometries, *Mater. Des.*, vol. 127, pp. 272–286, 2017, doi: 10.1016/j.matdes.2017.04.084.
29. P. Kaushik and D. K. Dwivedi, Effect of tool geometry in dissimilar Al-Steel Friction Stir Welding, *J. Manuf. Process.*, vol. 68, no. May, pp. 198–208, 2021, doi: 10.1016/j.jmapro.2020.08.007.
30. Y. Ni, L. Fu, Z. Shen, and X. C. Liu, Role of tool design on thermal cycling and mechanical properties of a high-speed micro friction stir welded 7075-T6 aluminum alloy, *J. Manuf. Process.*, vol. 48, no. September, pp. 145–153, 2019, doi: 10.1016/j.jmapro.2019.10.025.
31. A. M. Sadoun, A. Wagih, A. Fathy, and A. R. S. Essa, Effect of tool pin side area ratio on temperature distribution in friction stir welding, *Results Phys.*, vol. 15, no. November, p. 102814, 2019, doi: 10.1016/j.rinp.2019.102814.
32. L. Zhou, R. X. Zhang, G. H. Li, W. L. Zhou, Y. X. Huang, and X. G. Song, Effect of pin profile on microstructure and mechanical properties of friction stir spot welded Al-Cu dissimilar metals, *J. Manuf. Process.*, vol. 36, no. September, pp. 1–9, 2018, doi: 10.1016/j.jmapro.2018.09.017.
33. M. F. X. Muthu and V. Jayabalan, Tool travel speed effects on the microstructure of friction stir welded aluminum-copper joints, *J. Mater. Process. Technol.*, vol. 217, pp. 105–113, 2015, doi: 10.1016/j.jmatprotec.2014.11.007.
34. Y. Wei, J. Li, J. Xiong, and F. Zhang, Effect of tool pin insertion depth on friction stir lap welding of aluminum to stainless steel, *J. Mater. Eng. Perform.*, vol. 22, no. 10, pp. 3005–3013, 2013, doi: 10.1007/s11665-013-0595-y.
35. V. Chitturi, S. R. Pedapati, and M. Awang, Effect of tilt angle and pin depth on dissimilar friction stir lap welded joints of aluminum and steel alloys, *Materials (Basel)*, vol. 12, no. 23, pp. 1–11, 2019, doi: 10.3390/ma12233901.
36. X. Cao and M. Jahazi, Effect of tool rotational speed and probe length on lap joint quality of a friction stir welded magnesium alloy, *Mater. Des.*, vol. 32, no. 1, pp. 1–11, 2011, doi: 10.1016/j.matdes.2010.06.048.
37. Q. Guan, H. Zhang, H. Liu, Q. Gao, M. Gong, and F. Qu, Structure-property characteristics of Al-Cu joint formed by high-rotation-speed friction stir lap welding without tool penetration into lower

- Cu sheet, *J. Manuf. Process.*, vol. 57, no. May, pp. 363–369, 2020, doi: 10.1016/j.jmapro.2020.07.001.
38. H. Bisadi, A. Tavakoli, M. Tour Sangsaraki, and K. Tour Sangsaraki, The influences of rotational and welding speeds on microstructures and mechanical properties of friction stir welded Al5083 and commercially pure copper sheets lap joints, *Mater. Des.*, vol. 43, pp. 80–88, 2013, doi: 10.1016/j.matdes.2012.06.029.
39. C. W. Tan, Z. G. Jiang, L. Q. Li, Y. B. Chen, and X. Y. Chen, Microstructural evolution and mechanical properties of dissimilar Al-Cu joints produced by friction stir welding, *Mater. Des.*, vol. 51, pp. 466–473, 2013, doi: 10.1016/j.matdes.2013.04.056.