

Redefining Modern Living: The Evolution and Potential of Bluetooth-Enabled Smart Home Control Systems

Ajay Ghante^{1*}, Karan Anpat², Karan Utekar³, Prof. S. D. Mali⁴

Abstract

In the age of technological innovation, the concept of a "Smart Home control System" has emerged as a revolution in home automation. A smart home control system leverages the power of voice commands and Bluetooth connectivity to create a seamlessly integrated and efficient living environment. This system allows homeowners to control various aspects of their homes, such as lighting, appliances, security, and climate, with the convenience of simple voice commands and Bluetooth-enabled mobile devices. It represents a step forward in making homes more responsive, energy-efficient, and user-friendly, offering not only convenience but also the potential for increased security and reduced energy consumption. This introduction outlines the exciting possibilities and benefits of such a system, which can transform ordinary residences into intelligent and interconnected spaces. This innovative system not only enhances daily convenience but also plays a crucial role in ensuring the well-being of residents. It enables real-time monitoring of potentially hazardous situations such as gas leaks and unexpected motion, helping to prevent accidents and intrusions. The introduction of gas and motion sensors into a smart home control system reflects a commitment to both convenience and safety, making homes not only more responsive but also more secure and protected. In this research paper will explore the myriad benefits and possibilities that such a system can offer, turning homes into intelligent, connected, spaces.

Keywords: Smart Home Control System, Gas Leakage Sensor, Water Level Sensor, Motion Sensor, etc.

INTRODUCTION

The Smart Home Control system utilizes Bluetooth technology, enabling users to efficiently manage a myriad of electronic devices from their smartphones. The project recognizes the intrinsic value of time in people's lives and seeks to enhance user convenience by providing a centralized platform for device control. In the context of rapidly advancing technology, the report delves into the evolution of smart home solutions. It thoroughly examines the components and functionalities of the system, emphasizing its potential to revolutionize modern living.

*Author for Correspondence

Ajay Ghante¹
E-mail: anu_priya1031@yahoo.com

^{1,2,3}Student, Department of Electrical and Electronics Engineering, Sinhgad College of Engineering, Vadgaon, Pune

⁴Assistant Professor, Department of Electrical and Electronics Engineering, Sinhgad College of Engineering Vadgaon, Pune

Received Date: May 23, 2024

Accepted Date: May 29, 2024

Published Date: June 11, 2024

Citation: Ajay Ghante , Karan Anpat, Karan Utekar, S.D. Mali. Redefining Modern Living: The Evolution and Potential of Bluetooth-Enabled Smart Home Control Systems, International Journal of Telecommunications and Emerging Technologies. 2024; 10(1): 13–20p.

The system's key focus lies in providing users with an integrated and streamlined approach to managing their electronic ecosystem. From controlling lighting and climate to ensuring home security, the Smart Home Control system leverages the latest advancements to offer a comprehensive solution. The report underlines the impact of such automation on everyday life, shedding light on how it can not only save time but also contribute to improved energy efficiency.

As technology continues to evolve, the project

aligns itself with the increasing emphasis on interconnected devices and seamless control mechanisms. The report concludes by highlighting the pivotal role of home automation in shaping the future of smart homes, where the integration of various devices into a cohesive and responsive system promises to redefine the way, we live and interact with our living spaces.

In conclusion, the Home Automation system using Bluetooth transcends the realm of technological innovation; it symbolizes a paradigm shift towards more connected, responsive, and user-centric living spaces. As we navigate the intricacies of this transformative project, we invite you to envisage a future where efficiency, convenience, and personalization converge to redefine the way we experience and interact with our homes [610].

LITERATURE REVIEW

The research paper, "Internet of Things-Based Intelligent Smart Home Control System," delves into the realm of smart home automation. Drawing insights from multiple research articles and existing literature, the study focuses on elevating environmental control, energy management, and home security within the context of smart homes. The paper introduces an innovative smart home automation system that leverages Internet of Things (IoT) technologies, aiming to replace conventional home automation systems. This signals a transition toward a more intelligent and interconnected approach, redefining how various aspects of a home can be managed and controlled [12].

In our research endeavor outlined in section, we have developed an innovative smart-home indoor environment control system. This system utilizes OCF-Iotivity to optimize both energy consumption and overall comfort. Our paper introduces a pioneering Open Connectivity Foundation (OCF) prediction-assisted optimal control framework explicitly crafted for smart homes. A distinctive feature of our solution lies in its scalability, security, and seamless interoperability within broader Internet of Things (IoT) networks [3].

What sets our framework apart is its utilization of IoT devices to offload machine learning models. This strategic approach significantly enhances the precision of energy and thermal comfort modeling, leading to effective prediction-assisted optimization. This novel integration of technology promises to propel the capabilities of smart home systems, offering a more efficient and intelligent mechanism for controlling indoor environments [45].

PROPOSED METHOD

The proposed smart home control system centers around a centralized hub, integrating devices via standard protocols. It emphasizes essential components like smart lighting, climate control, and security, with automation and sensor integration [1]. Voice control and a user-friendly mobile app enhance accessibility, while energy efficiency, security measures, and integration with third-party services are key priorities for a streamlined and adaptable system.

The Intelligent Device Module forms the backbone of a sophisticated smart home system, orchestrating a symphony of interconnected devices designed to elevate the home environment. Within this framework, ordinary household items such as light bulbs, heaters, a microwave, fans, the television, and air-conditioners are endowed with a level of smartness that enables them to respond intelligently to commands. These devices seamlessly integrate into the home, providing users with the convenience of centralized control via a mobile app or other interfaces. Moreover, a network of sensors plays a pivotal role in data gathering, monitoring, and detection. Motion sensors enable the detection of movement, while gas, smoke, and fire detectors contribute to heightened safety measures. Temperature and humidity sensors monitor environmental conditions, optimizing comfort and energy efficiency. The inclusion of a smart camera enhances security by capturing images of potential intruders. In this Fig 1. Block Diagram controls every item. This holistic approach transforms the residence into a responsive and secure ecosystem, where automation, security, and safety coalesce for an enhanced living.

Smart Home Control System

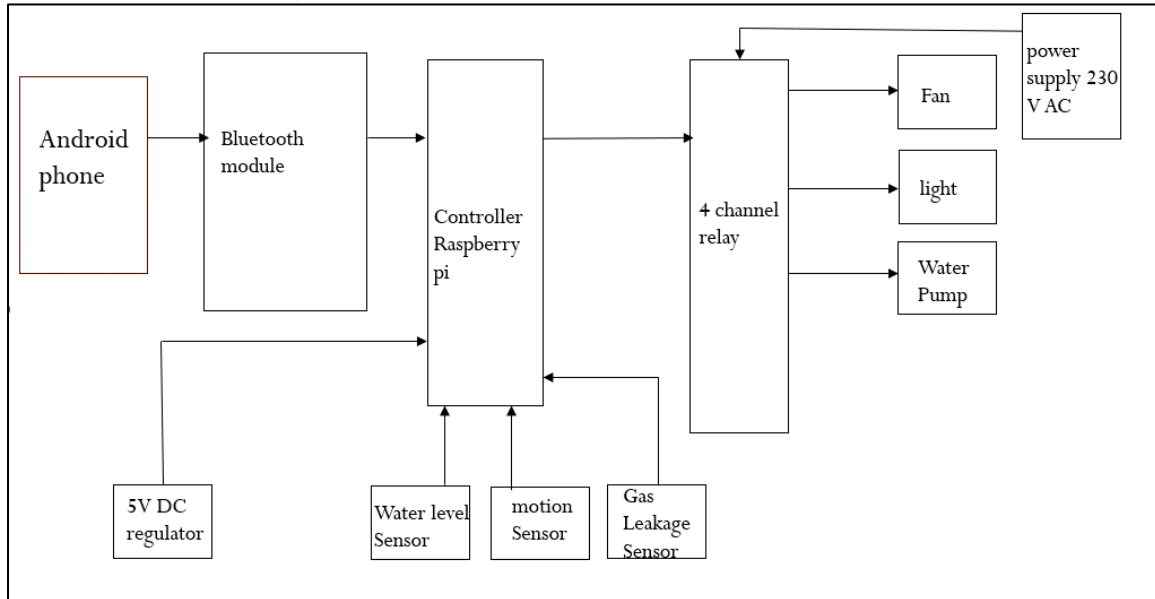

Fig 1. Block Diagram of Bluetooth-Enabled Smart Home Control Systems

Hardware

Raspberry Pi 4 Model B

The Raspberry Pi 4 Model B boasts enhanced video performance, supporting dual displays up to 4K through two micro-HDMI ports. With hardware decoding capabilities up to 4Kp60, it excels in processing H.265, H.264, and MPEG-4, making it a versatile choice for high-quality multimedia applications, including HD streaming and advanced video processing tasks. In this Fig 2. And Table No-1, Raspberry Pi 4 Model B there are some specifications.

Table No 01 -Specifications

Processor	Broadcom BCM2711, Quad core Cortex-A72 @ 1.8GHz [7]
Ram	1GB, 2GB, 4GB, or 8GB LPDDR4-3200 SDRAM
Wireless	2.4 GHz and 5.0 GHz IEEE 802.11ac, Bluetooth 5.0, BLE
Ethernet	Gigabit Ethernet
USB Port	2 x USB 3.0, 2 x USB 2.0
GPIO Header	Raspberry Pi standard 40 pin GPIO header
HDMI Ports	2 x micro-HDMI (up to 4kp60 supported)
Storage	Micro-SD card slot for operating system and data storage
Display Port	2-lane MIPI DSI display port
Camera Port	2-lane MIPI CSI camera port
Power	5V DC via USB-C connector (minimum 3A*), 5V DC via GPIO header

Fig 2. Raspberry Pi 4 Model B

Bluetooth Module

The Bluetooth module chosen for this project boasts a -80dBm sensitivity, facilitating reliable communication. With a powerful RF transmit capability of up to +4dBm, it ensures robust signal transmission. Operating efficiently at a low power range of 1.8V and 1.8 to 3.6V I/O, the module supports energy-efficient performance. Its edge connector extends the communication range from 10 to 100 meters, offering flexibility in device placement. Operating on the widely used 2.4 GHz frequency, now seen in fig -3, this Bluetooth module serves as a reliable and versatile component for the seamless connectivity and control features in our project.

Fig -3: Bluetooth Module

Channel Relay (4 Channel)

The 4-channel relay is a versatile electrical switch featuring 8 separate channels, each designed to control individual electrical circuits. With power consumption ranging from 8 to 16 watts, its efficiency varies based on the specific model and coil design. This relay configuration proves invaluable in managing multiple circuits, providing a reliable and energy-efficient solution for diverse applications. Now see in fig -4 Channel Relay (4 Channel)

Fig 4. Channel Relay

Gas Leakage Sensor

The gas leakage sensor operates on a low-power supply of 2.4V DC, making it energy-efficient. It detects LPG gas 30cm above the ground on the wall, while for coal gas and natural gas, it detects at 30cm below the ceiling. The sensor is designed to operate within a temperature range of 0°C to 49°C, ensuring reliability in various environmental conditions. Weighing 220g, it is lightweight and versatile. With a power consumption of 1W, this is Fig 5. Gas Leakage Sensor, the sensor offers an effective and efficient solution for gas leak detection.

Fig 5. Gas Leakage Sensor

Ultrasonic Sensor

The ultrasonic sensor functions optimally at a +5V power supply and boasts a theoretical distance measurement range spanning from 2cm to 450cm, although its practical effectiveness lies within the 2cm to 80cm range. With an impressive accuracy of 3mm and a narrow measuring angle of less than 15°, this sensor excels in providing precise distance measurements. Operating at a current consumption of less than 15mA and a frequency of 40Hz, this is Fig 6 and Table no -2. Ultrasonic Sensor now sees it strikes a balance between efficiency and performance, making it suitable for applications where accurate distance sensing is paramount.

Fig 6. Ultrasonic Sensor

Table No 02- Ultrasonic Sensors

Specification	Value
Operating Voltage	+5v
Theoretical Measuring Distance	2cm to 450cm
Practical Measuring Distance	2cm to 80cm
Accuracy	3mm
Measuring Angle Covered	<15°
Operating Current	<15mA
Operating Frequency	40Hz

Water Level Sensor

The water level sensor, identified as K-0135, operates efficiently with a low DC5V voltage supply, ensuring optimal performance while consuming less than 20mA of working current. Classified as an Analog sensor, it provides a continuous range of data, allowing for precise monitoring of water levels. Designed for versatility, the sensor demonstrates its adaptability by functioning within a working temperature range of 10°C to -30°C. In this Fig 7. Water Level Sensor weighing only 3g, this lightweight yet robust sensor is ideal for applications where accurate and reliable water level measurements are essential, making it a valuable component for various industrial and environmental monitoring systems.

Fig 7. Water Level Sensor

Water Pump

The water pump under consideration operates within a voltage range of 2.5-6V, providing flexibility in its application across various power sources. With a maximum lift capacity ranging from 40 to 110cm, it exhibits the capability to effectively move water over considerable heights. Additionally, the pump showcases an impressive flow rate, ranging from 80 to 120 liters per hour. This combination of adaptable voltage requirements, significant lift capacity, and a commendable flow rate positions the water pump as a versatile and efficient component, suitable for diverse scenarios such as irrigation systems, fountains, or other water circulation applications. In this Fig 8. Water Pump we see it.

Fig 8. Water Pump

Software Components

Proteus software (8.14)

Proteus Software version 8.14 continues the legacy of being a comprehensive electronic design automation (EDA) tool, widely utilized for circuit simulation and PCB design. This iteration likely retains the core features that have made Proteus popular among engineers and designers. With a voltage range of capabilities, Proteus supports circuit simulation, enabling users to design and test electronic circuits virtually before physical implementation. The software is known for its microcontroller simulation capabilities, aiding in the development and testing of embedded systems. PCB design is a key strength, allowing users to create and optimize the layout of printed circuit boards. Proteus boasts an extensive library of electronic components, facilitating the design process by providing a wide array of pre-modeled components for use in projects. Additionally, the software often features virtual instrumentation tools, allowing users to incorporate virtual oscilloscopes, function generators, and other instruments into their simulations. For microcontroller-based projects, Proteus offers code visualization and debugging tools, streamlining the development of embedded software. This is in Fig 9. Proteus software (8.14). While specific details about version 8.14 may require checking the official documentation, users can expect an advanced and versatile tool for electronic design and simulation.



Fig 9. Proteus software (8.14)

Arduino IDE

Within the Arduino IDE, programs take the form of sketches saved as .ino files. The text editor supports fundamental functions like cut, paste, and search/replace. The message area offers feedback on saving and displays errors. The console shows text output, including error messages. In the bottom right corner, the configured board and serial port are indicated in Fig 10. Arduino IDE. Toolbar buttons facilitate program verification, uploading, sketch management, and accessing the serial monitor for communication.

Fig 10. Arduino IDE

Arduino Bluetooth control app

Arduino Bluetooth Control is a versatile application designed for controlling Arduino boards through Bluetooth, enabling the creation of customized projects with new app features. The settings section provides adaptability through a simple and intuitive interface. The app conveniently remembers your Bluetooth module, attempting automatic connection to the last used one to streamline usage. This feature eliminates the need to manually select the module every time you use the application.

METHODOLOGY

In the intricate process of developing a smart home automation system, a systematic approach is employed to ensure efficiency and effectiveness. The journey commences with a meticulous Requirement Analysis, delving into the specific needs and aspirations of the project. This phase serves as the foundation, identifying key areas within the home that can benefit from automation. Following a thorough understanding of requirements, the System Design phase takes center stage, crafting a detailed plan that encompasses both hardware and software elements, along with communication protocols crucial for seamless operation. With the blueprint in hand, Component Selection ensues, strategically choosing sensors, controllers, actuators, and communication modules that align with project requirements and financial considerations. Integration then brings these components together, weaving them into a cohesive system that communicates seamlessly. A critical aspect of user interaction, the User Interface Design phase focuses on creating an intuitive platform, ensuring homeowners can effortlessly control and monitor automated devices. Finally, the Testing and Quality Assurance stage rigorously examines the system's performance under diverse conditions, making necessary refinements to enhance reliability.

1. Requirement Analysis: Understand the specific needs and goals of the project, considering the various aspects of automation required in the home.
2. System Design: Create a comprehensive plan outlining the hardware and software components, as well as the communication protocols and interfaces necessary for the system.
3. Component Selection: Choose appropriate devices and components such as sensors, actuators, controllers, and communication modules based on the requirements and budget constraints.
4. Integration: Configure and integrate the selected components into a cohesive system, ensuring compatibility and seamless communication between different elements.
5. User Interface Design: Develop an intuitive and user-friendly interface that allows homeowners to easily control and monitor the automated devices within the home.
6. Testing and Quality Assurance: Conduct rigorous testing to ensure the system operates reliably and efficiently under various conditions and make any necessary adjustments to enhance its performance.

Result & Discussion

Simulation results of the proposed circuitry system is shown in figure 11. and the hardware system you can see in figure 12.

Simulation Result

Fig 11. Simulation result of the proposed system

Hardware Result

Fig 12: Hardware result of the proposed system

Discussion

The simulated Smart Home Control System, realized through the synergy of Proteus software and the Bt_display app, redefines the landscape of home automation. Its standout feature lies in the seamless integration of mobile devices at the system's core, leveraging the latest in communication technologies. This not only enhances user accessibility but also transforms home automation into an intuitive and visually engaging experience. The system's flexibility, combined with a visually appealing interface, sets it apart from conventional setups, promising a more personalized and enjoyable approach to managing one's living space.

At the heart of this innovative system are three pivotal components: a Bluetooth module, an Arduino microcontroller, and relay circuits. This trifecta forms the backbone of the system, providing not just adaptability but also a sophisticated means of controlling various aspects of the home environment. The integration of these components reflects a forward-looking approach, emphasizing not only efficiency but also intelligence in managing home functionalities [5]. As the Smart Home Control System paves the way for a more responsive and user-centric future, it stands as a testament to the evolving landscape of modern home automation, where convenience meets cutting-edge technology.

Applications

1. Automated Home Lighting
2. Time-Saving Kitchen Appliances
3. Centralized Control via Mobile App
4. Time-Efficient Laundry Management
5. Automated Home Office Setup
6. Energy-Efficient Home

CONCLUSION

The home controlling system represents a specialized device designed to effortlessly manage home appliances. Our created device stands out for its compact size, cost-effectiveness, and high compatibility. It not only enhances energy efficiency but also tailors the living environment to individual preferences. This system empowers users by enabling remote control and automation of various devices, streamlining daily tasks, and offering peace of mind through real-time monitoring and security features.

ACKNOWLEDGEMENT

We express our heartfelt gratitude, recognizing that words fall short in conveying the depth of our appreciation for the invaluable help and support we've received from many individuals. While it's challenging to encapsulate our feelings in a few words, we believe it's important to extend our sincere thanks to everyone who contributed to our journey.

First and foremost, our deepest gratitude goes to our esteemed guide, Prof. S. D. Mali. His unwavering guidance, patience, and support have been instrumental in our project's success. His encouragement and constructive feedback propelled us forward, allowing us the freedom to excel under his supervision.

A special thanks to Prof. C.R Kuwar, the project coordinator in the Department of E&TC, for consistently motivating us throughout the project. We also extend our sincere thanks to Dr. M. B. Mali, the Head of the Department of E&TC, for his cooperation and valuable suggestions. Our appreciation also goes to Dr. S. D. Lokhande, Principal of Sinhgad College of Engineering, whose leadership has been a continuous source of inspiration for us to work diligently.

Lastly, we owe a debt of gratitude to our families and friends whose love and blessings provided the driving force behind the completion of this project. Each contribution, big or small, has played a significant role in our success, and for that, we are truly thankful.

REFERENCES

1. B. Veerasamy, B. G. Durga, T. H. M. Kumaran, I. V. Devika, and M. J. Akshaya present a paper on "Sensor for Low Power and Long-Range Access" in the 2023 7th International Conference on Trends in Electronics and Informatics (ICOEI), published by IEEE in 2023.
2. Anam Khan, et al., Ensemble prediction approach based on learning to statistical model for efficient building energy consumption management, *Symmetry* 13 (2021) 405, <http://dx.doi.org/10.3390/sym13030405>.
3. Ji-Ying Shi, et al., Moth-flame optimization-based maximum power point tracking for photovoltaic systems under partial shading conditions, *J. Power Electron.* 19 (5) (2019)12481258, <http://dx.doi.org/10.6113/JPE.2019.19.5.1248>.
4. M.C. Akkaya, A. Polat, L.T. Ergene, Mpppt based adaptive control algorithm for small scale wind energy conversion systems with PMSG, in 2019 International Aegean Conference on Electrical Machines and Power Electronics (ACEMP) & 2019 International Conference on Optimization of Electrical and Electronic Equipment (OPTIM), 2019, pp. 517522, <http://dx.doi.org/10.1109/ACEMPOPTIM44294.2019.9007135>.
5. Ali Kadhum M Al-Qurabat, Suha Abdulhusein Abdulzahra, Ali Kadhum Idrees, Two-level energy-efficient data reduction strategies based on SAX-LZW and hierarchical clustering for minimizing the huge data conveyed on the Internet of things networks, *J. Supercomput.* (2022) 1–47.
6. M. V. Gladence, M. V. Anu, R. Rathna, and E. Brumancia propose a "Recommender System for Home Automation using IoT and Artificial Intelligence" in the *Journal of Ambient Intelligence and Humanized Computing* in 2020.
7. A. D. Jadhav, S. D.Mali, "RTOS based MODBUS protocol implementation on ARM-7 processor", *ICWET '11: Proceedings of the International Conference & Workshop on Emerging Trends in Technology*, February 2011, ISBN:9781450304498, DOI:10.1145/1980022, Publisher: Association for Computing Machinery New York, NY, United States.
8. Prof. S. D. Mali¹, Rudrani Kale², Sagar Ghode³, Swarag Baad⁴, "Generic Board for Industrial Appliance using IoT and GUI", *International Journal of Advanced Research in Science, Communication and Technology (IJARSCT)*, Volume 3, Issue 8, pg 657-660, April 2023, DOI: 10.48175/IJARSCT-9635 657, ISSN (Online) 2581-9429.
9. Tanvi Mannapur¹, Prasad Palange², Amey Bhavsar³, S. D. Mali⁴, "RFID Technology in Retail: A Study on IoT-Based Shopping Cart System", *International Journal of Advanced Research in Science, Communication and Technology (IJARSCT)*, Volume 3, Issue 2, pg 265-272, May 2023, DOI: 10.48175/IJARSCT-9748, ISSN (Online) 2581-9429.
10. Nishant Shrira¹, Shoebh Shaikh², Shantanu Salunke³, S. D. Mali⁴, "Intelligent Battery Swapping System Using IOT", *International Journal of Advanced Research in Science, Communication and Technology (IJARSCT)*, Volume 3, Issue 8, pg 308-312, May 2023, DOI: 10.48175/IJARSCT-10294, ISSN (Online) 2581-9429