

# Implementation of Vehicle Collision Monitor System Using IoT

Rekha Murthy<sup>1,\*</sup>, Brijesh R.<sup>2</sup>, Dilip C.<sup>3</sup>, Abhishek S.K.<sup>4</sup>

## Abstract

*The loss of life in traffic accidents causes terrible problems that have an adverse effect on the socioeconomic advancement of societies. Most developing nations are reporting greater rates of fatalities whenever a crisis arises due to a lack of an efficient mechanism for promptly notifying the emergency services of accidents so that they can begin rescue efforts right away. In addition, the likelihood of survival for every accident victim mostly depends on how fast emergency medical services can reach the closest hospital to treat the victims after they arrive on the site. On occasion, though, excessive traffic causes these rescue vehicles to be delayed on their way to the accident scene. This system delivers address information to intended security, medical, and other recipients while using an accelerometer to correct the vehicle's tilting and crashing.*

**Keywords:** Arduino Nano, Global Positioning System, GSM, accident, emergency service provider

## INTRODUCTION

Road accidents is a significant global concern, causing a significant loss of life and economic impact. Prompt detection and efficient response to vehicle accidents are crucial in minimizing injuries and fatalities. Traditional accident reporting mechanisms heavily rely on human intervention, which can lead to delays in emergency response.

But as Internet of Things (IoT) technology develops quickly, a new paradigm of exploit systems has surfaced that promises to transform emergency services.

The IoT-based vehicle accident detection and rescue a network of interconnected devices and sensors to detect accidents in real-time and trigger an immediate response. By integrating IoT capabilities into vehicles, crucial parameters such as acceleration, location and impact forces.

Additionally, the system aims to overall coordination and communication between accident victims, emergency responders and medical professionals. The IoT-based vehicle emancipation is its ability to

### \*Author for Correspondence

Rekha Murthy

E-mail: rekha.murthy@saividya.ac.in

Assistant Professor, Department of CSE (AI & ML), Sai Vidya Institute of Technology, Bengaluru, Karnataka, India

Student, Department of EEE, Sai Vidya Institute of Technology, Bengaluru, Karnataka, India

Received Date: May 06, 2024

Accepted Date: May 24, 2024

Published Date: August 22, 2024

Citation: Rekha Murthy, Brijesh R., Dilip C., Abhishek S.K. Implementation of Vehicle Collision Monitor System Using IoT. Journal of Automobile Engineering and Applications. 2024; 11(2): 41–48p.

transmit real-time accident information to a centralized control center. This central hub serves as a command center to emergency services, facilitating immediate assessment of the severity and enabling efficient resource allocation. The control center can rapidly dispatch appropriate emergency response units to site location information received from the IoT devices.

## LITERATURE SURVEY

Accidents are rising at a never-before-seen rate in tandem with an increase in automobile ownership. Among all deaths, accidents account for 1.24 million deaths annually. In India, inebriation,

fatigue, and poorly engineered speed limiters are the key contributing factors to these collisions. These underlying causes cannot be prevented by any practical means. The suggested technique offers a practical, affordable, and instantaneous way to stop auto accidents. An warning is sent when the reading exceeds predetermined threshold values, and the vehicle will cut the gasoline supply if the driver does not respond within the allotted time. The current system makes use of an Arduino microcontroller in conjunction with an accelerometer, webcam, MQ3 sensor, and infrared sensor [1].

Significant collisions on local, freeway, and interstate routes can have profound social and financial effects. While large accidents involving the deployment of airbags necessitate the prompt attention of authorities, minor accidents can be managed by the passengers escorting to hospitals. When an instantaneous change in acceleration, rotation, or impact force is detected in one of the vehicle's ends, Automatic an auto-detection unit system that instantly notifies an Emergency Contact through text message, providing the location and time of the accident [2].

An automated notification service that allows authorities to be immediately aware of any accidents that occur in their respective cities to allow them to take immediate action and prevent as much damage as possible, both humans and economic [3].

Researchers have proposed an intelligent accident detection approach in this paper that can identify an accident at any time or place and notify the closest "service provider." The service provider sets up the required assistance. A sensor is used by a new technology that can be installed in any car to locate the collision. The PIC16F877A microcontroller is responsible for processing and monitoring the sensor output.

This setup intelligently transmits signals during the mishap according to the received signal the place of accident can be known. Finally made realistic by making some tie up with car companies and during the manufacture the transmitter module can be set up within it. Even the old cars can be given an option of setting it. It is preferable to have this setup in the vehicles as human life can be saved as immediate reporting is done as accident is detected [4].

## PROPOSED BLOCK DIAGRAM

### Problem Statement

- *Delayed Accident Detection:* The delay can significantly impact the response time of emergency services, potentially resulting in increased injuries or fatalities.
- *Inaccurate Accident Reporting:* Errors can occur in human perception and memory, which can result in inaccurate accident reports.
- *Limited Communication Channels:* Communication between accident victims, emergency responders and medical professionals is often limited during the critical moments following an accident.
- *Inefficient Resource Allocation:* Without accurate and real-time accident data, emergency response teams may struggle to allocate the appropriate resources promptly.
- *Lack of predictive capabilities:* Traditional systems often lack the ability to predict the severity of injuries sustained by the vehicle occupants [5].

### Proposed System

- A 9V DC is supplied to the model, LM2596 DC-DC buck converter is used to step down the given input voltage to in between 3.5V to 4.2V. The input voltage is reduced to half the given input voltage because the components used here do not withstand high voltages and work at a low voltages below 5V. As soon as the vehicle meets with an accident, there is a change in x,y,z-axis of the ADXL-335 accelerometer sensor [6].
- This provides a signal to the GPS and GSM module that the vehicle has met with an accident/some issues with the vehicle, probably accident message to the emergency provider (Figure 1).

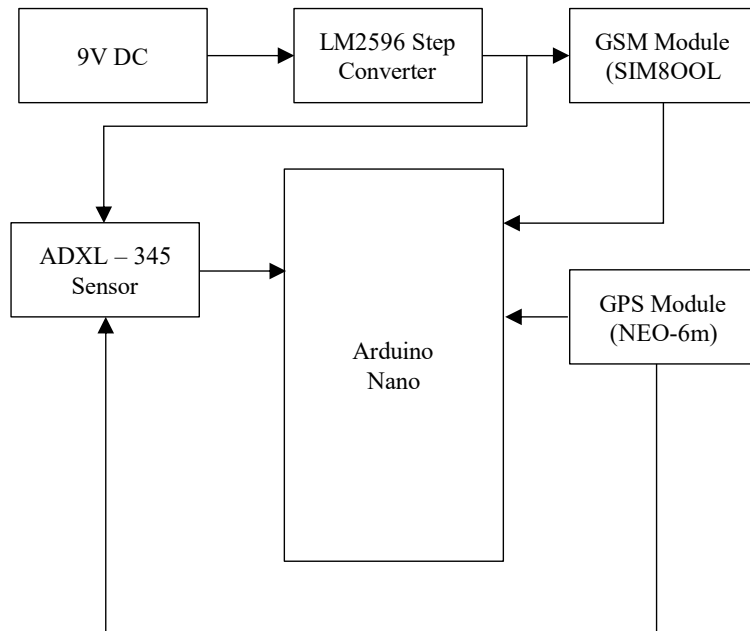

**Figure 1.** Block Diagram of Proposed system.

### Methodology

- When a passenger/driver is met with an accident, a rescue message is sent.
- When accident occurs the ADXL-345 accelerometer sensor senses the accident.
- The GSM module SIM800L connects to the network once the sensor senses the accident.
- Once the GSM module connects to the network, the GPS module Neo-6m sends the accident location to the rescuer.
- The rescuer first gets a call, if not received then a alert message with accident location will be sent to the rescuer [7].

## HARDWARE COMPONENTS IMPLEMENTATION

### Arduino Nano

This device is a compact and versatile microcontroller board based on the ATmega328P chip. It's part of the Arduino family of boards, known for their ease of use and extensive community support. The Arduino Nano is particularly popular among hobbyists, students, and makers due to its small size and wide range of applications (Figure 2)

### SIM800L (GSM MODULE)

The SIM800L GSM/GPRS module is a miniature GSM modem that can be used in a variety of IoT projects (Figure 3).



**Figure 2.** Arduino Nano.



**Figure 3.** SIM800L GSM module.



**Figure 4.** NEO-6M GPS modul.

### NEO-6M GPS MODULE

This module is a sturdy GPS receiver that improves satellite search performance with an included  $25 \times 25 \times 4$  mm ceramic antenna. Real-time module status monitoring is provided by the power and signal indicators. There are four pins on it: VCC, TxD, RxD, and GND. The microcontroller and TxD and RxD pins are used for communication [8]. The GPS module's ground pin, or GND, needs to be linked to the ESP32's ground pin. With an integrated ceramic antenna measuring  $25 \times 25 \times 4$  mm, the NEO-6M GPS module is a sturdy GPS receiver that improves satellite search performance (Figure 4).

### LM2596 DC-DC Buck Converter

Smaller filter components than those that may be needed with switching regulators at lower frequencies can be used because the LM2596 series operates at a switching frequency of 150 kHz. A regular 5-pin TO-220 package with multiple lead bend options and a 5-pin TO-263 surface mount package are also available (Figure 5).

The LM2596 is a popular and widely used buck converter integrated circuit (IC) developed by Texas Instruments.

### ADXL-335 ACCELEROMETER SENSOR

The ADXL335 is a popular analog accelerometer sensor developed by Analog Devices. It is designed to measure acceleration in three axes: X, Y, and Z. Here's a detailed overview of the ADXL335 accelerometer sensor: Measurement Principle: The ADXL335 is based on the microelectromechanical systems (MEMS) technology, which employs a tiny, microfabricated structure with a built-in proof mass (Figure 6).



**Figure 5.** LM2596 DC-DC Buck Converter.



**Figure 6.** ADXL-335 Accelerometer sensor.



**Figure 7.** 9V DC battery.

### **9V DC BATTERY**

A 9V DC battery is a compact and commonly used power source (DC) voltage at a nominal voltage of 9 volts. It is often used in a variety of electronic devices and applications that require a relatively higher voltage compared to standard AA or AAA batteries [9]. The 9V DC battery typically consists of six individual 1.5V cells connected in series, resulting in a combined voltage of 9 volts. It is available in different chemistries, including alkaline, lithium, and rechargeable variants, offering various features and performance characteristics to suit different requirements (Figure 7).

## SOFTWARE IMPLEMENTATION

### Software Requirements

Software requirements deal with what software resources and prerequisites has to installed on a computer in order for a program to run as efficiently as feasible.

#### Arduino IDE

- When the system starts, then a 9V DC battery is given as the supply the system.
- It is then given to the LM2596 to step down the input voltage to 5V.
- The programmed Arduino Nano sends signal to all the components when there is a change in axis of the ADXL-335 accelerometer sensor (Figure 8).

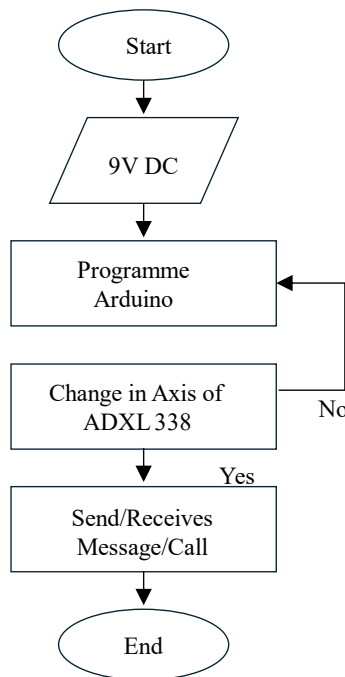

**Figure 8.** Flowchart for proposed system.

## DISCUSSION ON RESULTS

- An IoT-based vehicle accident detection and rescue system has the potential to significantly improve response times and save lives in emergency situations.
- *Real-time accident detection:* Vehicle-mounted Internet of Things (IoT) sensors are able to continuously track a number of characteristics, including position information, airbag deployment, and acceleration and deceleration. Through real-time data analysis, the technology is able to precisely identify and detect incidents as they happen. This shortens the time it takes for rescue crews to get at the accident scene and permits quick emergency reaction.
- *Immediate notification:* Once an issue is detected, the IoT system can automatically send alerts to relevant parties, including emergency services, nearby hospitals, and even the contacts of the affected individuals. This quick and automated notification helps ensure that help arrives as soon as possible, increasing the chances of saving lives and reducing the severity of injuries as shown in Figure 9
- *Location tracking and mapping:* By integrating GPS or other location tracking technologies, data can be shared with emergency services, allowing them to quickly navigate to the scene, particularly in cases where the accident occurs in remote or unfamiliar areas. Accurate mapping also enables optimized routing for emergency vehicles, potentially saving valuable time shown in the Figure 10.

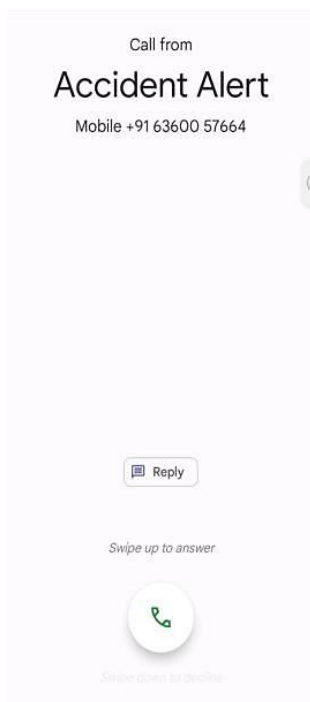

**Figure 9.** After execution, call alert.

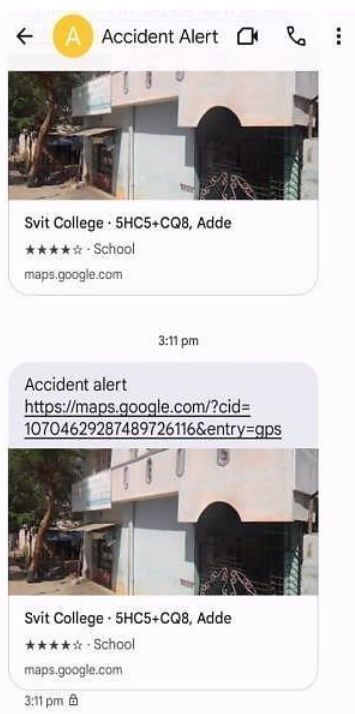

**Figure 10.** After execution, SMS alert.

## CONCLUSION AND FUTURE SCOPE

### Conclusion

Driver irresponsibility and reckless driving are the primary causes of road fatalities. The authority will be able to use the internet to monitor the driving quality characteristics with this proposed system from anywhere in the world. Thus, the suggested system plays a critical role in ending and lowering the total number of accidents. In order to guarantee a prompt rescue effort, the driver or passenger can also

transmit accident information—including the location of the accident—instantaneously to the appropriate authorities. To install the system, the car does not need to be modified in any way.

### Future Scope

- *Enhanced Accuracy and Real-Time Monitoring*: Future developments can focus on improving the accuracy of accident detection algorithms and sensor technologies used in the system.
- *Predictive Analytics and Machine Learning*: By leveraging the power of machine learning algorithms and predictive analytics, future iterations of the system can analyze historical accident data to identify patterns and risk factors.

### REFERENCES

1. Vivek Kinage MIT ADT University Information Technology Pune, Maharashtra, India, Piyush Patil Pune University Computer Science Pune, Maharashtra, India, IoT Based Intelligent System For Vehicle Accident Prevention And Detection At Real Time, *IEEE 2019 Third International conference on I-SMAC (IoT in Social, Mobile, Analytics and Cloud) (I-SMAC)*, <https://doi.org/10.1109/I-SMAC47947.2019.9032662>
2. Nazir Ahmmmed, Nusrat Jahan Jenny, Most Fowziya Akther Houya, Anika Ibnat Binte Alam, Md. Adnan Arefeen, Dept. of CSE United International University Dhaka, Bangladesh, VADet: An Arduino based automated vehicle accident detection and messaging system, *IEEE 2019 1st International Conference on Advances in Science, Engineering and Robotics Technology (ICASERT)*, <https://doi.org/10.1109/ICASERT.2019.8934649>
3. Md Habib Ullah Khan, Md Mamun Howlader, Department of ECE, North South University, Dhaka, Bangladesh. Design of an Intelligent Autonomous Accident prevention, Detection and Vehicle Monitoring System (2019 ).*IEEE 2019 IEEE International Conference on Robotics, Automation, Artificial- intelligence and Internet-of-Things (RAAICON)*, <https://doi.org/10.1109/RAAICON48939.2019.6263505>
4. Asad Ali and Mohammad Eid, Applied Interactive Multimedia (AIM) Laboratory, Division of Engineering, New York University, Abu Dubai, United Arab Emirates, An Automated System for Accident Detection (2015), *2015 IEEE International Instrumentation and Measurement Technology Conference (I2MTC) Proceedings*, <https://doi.org/10.1109/I2MTC.2015.7151519>
5. Bujang, S. H., Suhaimi, H., & Abas, P. E. (2020, December). Performance of low cost Global Positioning System (GPS) module in location tracking device. In *IOP Conference Series: Materials Science and Engineering* (Vol. 991, No. 1, p. 012137). IOP Publishing.
6. del Rio, T. L., Gracia, G. J., & Moreno, L. N. O. (2016). Electronic system to monitor the truck route in the Mexico City. In *2do Congreso Internacional de*.
7. Giudici, A., Torsvik, T., & Soomere, T. (2017). Development of a Flexible, Extendable, and Low-Cost Control Unit for Surface Drifters. *Journal of Atmospheric and Oceanic Technology*, 34(3), 669-677.
8. Giammarini, M., Isidori, D., Pieralisi, M., Cristalli, C., Fioravanti, M., & Concettoni, E. (2016). Design of a low cost and high performance wireless sensor network for structural health monitoring. *Microsystem Technologies*, 22(7), 1845-1853.
9. Jose, C., Dhivvy, J. P., & Das, D. K. (2019, October). Autonomous Navigation and Collision Avoidance Surface Watercraft for Flood Relief Operations. In *2019 IEEE Global Humanitarian Technology Conference (GHTC)* (pp. 1-8). IEEE.