

Smart Vehicle Tracking with Anti-Theft and Accident Detection System

Vijay Badrinath Diwan^{1,*}, Vikas Sangappa Birajdar², Bholanath Mahadeorao Bahur³, N.V. Kale⁴

Abstract

This paper introduces a comprehensive Smart Vehicle Tracking System equipped with advanced functionalities such as live vehicle tracking, real-time fuel monitoring, anti-theft measures, and accident detection systems. Transportation systems have been completely transformed by the incorporation of cutting-edge technologies into automobiles, which have increased efficiency, safety, and security. Due to their ability to reduce the risks associated with auto theft and accidents, smart vehicle tracking systems with anti-theft and accident detection features have attracted a lot of attention among these technologies. The anti-theft and accident detection features of smart car tracking systems are the main topics of this research paper's thorough analysis of the body of knowledge and cutting-edge technologies. The study looks at the fundamental ideas, essential elements, and working mechanisms of these kinds of systems, as well as the advantages and disadvantages of them. In addition, it addresses current developments, new trends, and potential paths in this area with the goal of providing understanding for scholars, professionals, and decision-makers who are engaged in automotive security and safety. The primary goal of this system is to enhance the security and safety of vehicles while providing owners with valuable insights into their vehicle's status.

Keywords: ESP 32 microcontroller, Ultrasonic sensor, Neo-6M GPS module, MPU 6050 gyroscope and accelerometer sensor, Relay, motor, Power supply.

INTRODUCTION

The advent of smart technologies has revolutionized the automotive industry, paving the way for innovative solutions to address the challenges of vehicle security and safety. One such groundbreaking development is the Smart Vehicle Tracking System, a sophisticated integration of live vehicle tracking, real-time fuel monitoring, anti-theft measures, and accident detection systems. This comprehensive system is designed to empower vehicle owners with unprecedented control and insights into their vehicles, all conveniently accessible through a dedicated mobile application.

*Author for Correspondence

Vijay Badrinath Diwan

E-mail: vijaydiwan.scoe.entc@gmail.com

¹⁻³Student, Department of Electronics & Telecommunication, Sinhgad College of Engineering, Savitribai Phule University, Pune, Maharashtra, India

⁴Professor, Department of Electronics & Telecommunication, Sinhgad College of Engineering, Savitribai Phule University, Pune, Maharashtra, India

Received Date: April 25, 2024

Accepted Date: May 03, 2024

Published Date: May 24, 2024

Citation: Vijay Badrinath Diwan, Vikas Sangappa Birajdar, Bholanath Mahadeorao Bahur, N.V. Kale. Smart Vehicle Tracking with Anti-Theft and Accident Detection System. Journal of Automobile Engineering and Applications. 2024; 11(1): 1–8p.

In an era where mobility is a cornerstone of modern living, the ability to monitor the whereabouts of vehicles in real-time has become paramount. The live vehicle tracking feature of this system utilizes state-of-the-art Global Positioning System (GPS) technology, enabling owners to track their vehicles on a digital map directly from their mobile devices. Whether it's monitoring a fleet of vehicles or keeping tabs on a personal car, this feature ensures that owners stay informed about the location and movement of their vehicles at any given moment. Fuel theft has become a growing concern in the automotive industry. To combat this issue, the Smart Vehicle Tracking System

incorporates live fuel monitoring directly on the mobile application. Owners can now keep a close eye on their vehicle's fuel consumption in real-time, ensuring transparency and enabling them to detect any anomalies that may indicate unauthorized fuel siphoning [1].

In addition to live tracking and fuel monitoring, the system boasts an advanced anti-theft mechanism. Geofencing technology establishes virtual boundaries, triggering instant alerts on the mobile application if a vehicle moves beyond predefined areas. This proactive measure allows owners to respond swiftly to potential theft incidents, enhancing the security of their vehicles.

Furthermore, the system incorporates an accident detection feature that utilizes sensors and accelerometers. In the unfortunate event of a collision, the system instantly notifies the vehicle owner via the mobile application. This real-time alert empowers owners to take prompt action, such as contacting emergency services or providing assistance to those involved in the accident [2].

LITERATURE SURVEY

The introduction of an article titled "GPS Based Vehicle Tracking System" published in the International Journal of Scientific & Technology Research in June 2021. It includes information on the software and hardware development of a vehicle tracking system using an Arduino Mega2560 microcontroller board, SIM900A GSM module, NEO-6 GPS module, and LM2596 series regulator. The article also discusses the testing of the system indoors and outdoors. The introduction of the study titled "Accident Detection and Alerting Systems: A Study" explains that the increasing number of vehicles on roads, coupled with the lack of emergency facilities and poor communication to concerned authorities, has resulted in a high rate of fatalities due to road accidents. The study proposes the use of an accelerometer and vibration sensor to detect and recognize severe accidents. This information is sent through a GSM module, including the latitude and longitude data provided by the GPS module to alert and direct necessary action by the police control room, rescue team, or car owners [3]. The system aims to save lives in isolated areas where accidents occur and no one is around to report the accident. The paper named Vehicle speed detection using Arduino and IR sensors contain important information related to a research article published in the Journal of Emerging Technologies and Innovative Research (JETIR). The article discusses the design and implementation of a system for vehicle speed detection using Arduino and IR sensors. The system is capable of monitoring the vehicle speed and displaying it on an LCD module while also providing over-speed alerts through a buzzer. The article includes detailed information on the various hardware components used in the system and their integration with the Arduino microcontroller. Additionally, the article provides references to related research papers that may be useful for further study [4–7].

The paper contains information about the International Journal for Research in Applied Science & Engineering Technology (IJRASET), including its ISSN, IC Value, and SJ Impact Factor. It also includes an abstract for a paper on a vehicle tracking and fuel monitoring system using IoT technology. Additionally, the paper outlines the system's objectives and workflow, including initialization, data acquisition, and data processing. Page 2 provides more detailed information about the paper's keywords and the implementation of the proposed system (Figure 1).

Component

ESP 32 Microcontroller

The ESP32 is a versatile microcontroller developed by Espressio Systems, known for its integrated Wi-Fi and Bluetooth capabilities, widely used in IoT (Internet of Things) applications (Figure 2).

NEO-6M GPS Module

The Neo-6M is a compact and cost-effective GPS module commonly used for accurate positioning and navigation in electronic projects, featuring a small form factor and low power consumption (Figure 3).

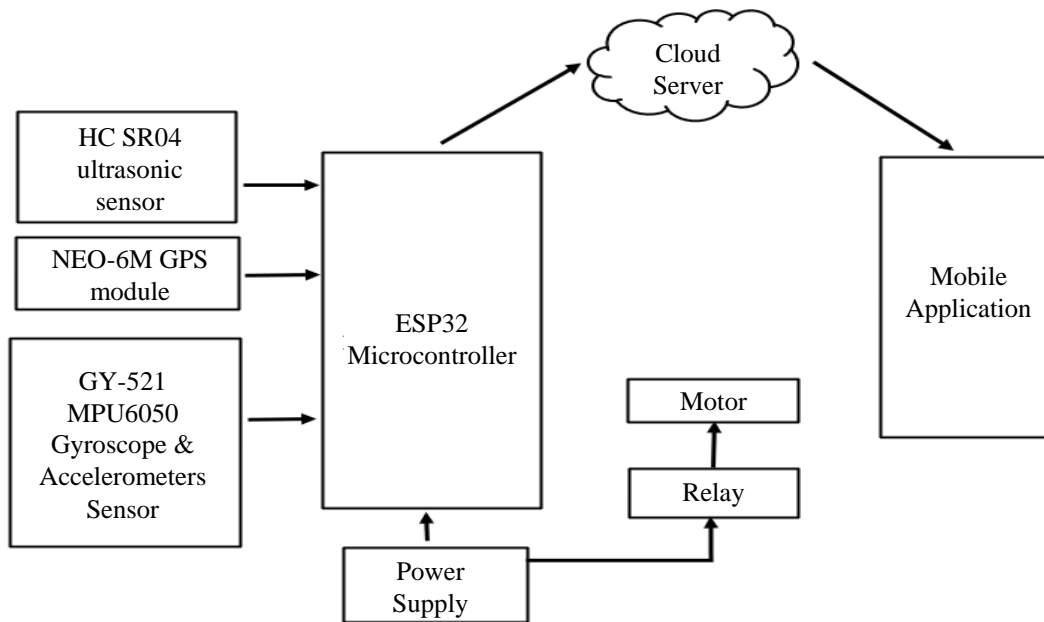

Figure 1. Smart vehicle tracking with anti theft and accident detection system.

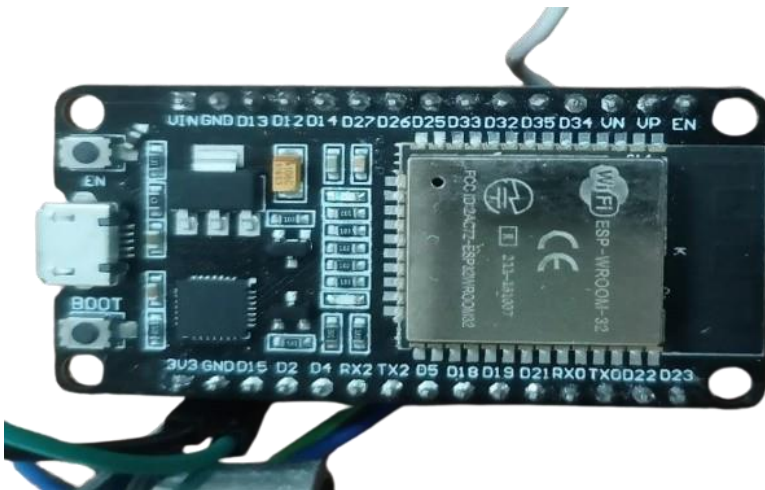

Figure 2. ESP32.



Figure 3. Neo-6M.

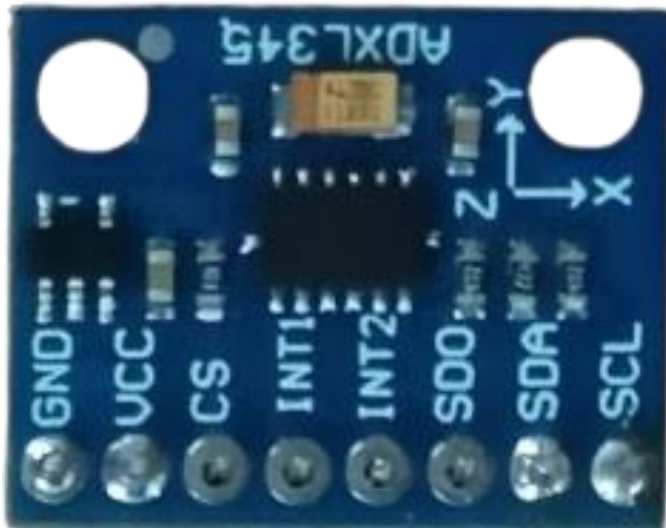

Figure 4. MPU-6050.



Figure 5. Relay.

MPU6050 Gyroscope and Accelerometer

The MPU-6050 is a 6-axis motion-tracking device that combines a 3-axis gyroscope and a 3-axis accelerometer, enabling precise measurement of angular motion and acceleration, commonly used in applications such as robotics and motion sensing (Figure 4).

Relay

A 5V relay is an electromagnetic switch that can be controlled with a 5-volt signal, commonly used to control higher voltage and current devices in electronic circuits (Figure 5).

METHODOLOGY

In the implementation of the project, the focal point is the utilization of the ESP32 microcontroller, serving as the central unit orchestrating communication between the sensors and the cloud server. This microcontroller plays a pivotal role in the seamless integration of components within the system, ensuring efficient data transfer and processing. here ESP32 is typically programmed to connect to the Blynk cloud server, and the mobile app connects to the same server. Data is exchanged through this intermediary, and we design the user interface on the mobile app to interact with the ESP32. To enable the ESP32 to work with a mobile application, we program it using Blynk library. The code for the device will read the data from the sensors and detect any unusual conditions. For example, the code could detect a low fuel level, a sudden change in the vehicle's orientation (indicating an accident), or

unexpected movement of the vehicle (indicating theft). Once the code detects an unusual condition, it can take appropriate action, such as sending an alert message [8].

The Anti-Fuel Theft System aims to develop a robust mechanism for detecting fuel theft in stationary vehicles. The system is designed to operate by employing sensors that monitor fuel levels when the vehicle is not in motion. Here we use ultrasonic sensor for measuring fuel level in fuel tank, Ultrasonic sensors generate high-frequency sound waves, typically beyond the range of human hearing (ultrasonic waves) Common frequencies used are around 40 kHz, these ultrasonic waves travel through the air in a directional pattern. They move outward in a cone-shaped beam from the sensor. When the sound waves encounter on fuel surface in their path, they bounce off the fuel surface. This is known as an echo. Using the speed of sound (which is approximately 343 meters per second in air at room temperature), the sensor calculates the distance to the fuel surface by multiplying the time it took for the sound wave to return by the speed of sound and dividing by 2 (since the sound wave travels to the fuel surface and back). The calculated distance is typically provided as an output from the sensor, often in the form of a digital reading [9]. In the event of a reduction in fuel levels, indicative of potential fuel theft, the sensors promptly relay this data to the ESP32 microcontroller. The microcontroller, serving as the central processing unit, further transmits the information to mobile application. Consequently, the vehicle owner receives an immediate alert message, notifying them of the suspicious activity. It's worth noting that the system employs a contextual approach to avoid unnecessary alerts when the vehicle is in motion. Specifically, if the vehicle is moving and the sensors detect a reduction in fuel levels, the system refrains from triggering an alert to the owner, acknowledging the impracticality of fuel theft during vehicle operation. This refined approach ensures the system's effectiveness in accurately identifying and notifying owners of potential fuel theft incidents while minimizing false alarms during regular vehicle usage.

The integration of the NEO-6M GPS module with the ESP32 microcontroller establishes a robust and efficient mechanism for accurate location tracking in the project. The NEO-6M GPS module operates by receiving signals from multiple satellites, allowing it to triangulate the device's precise geographical coordinates, including latitude, longitude, and altitude. In conjunction with the ESP32 microcontroller, the GPS module seamlessly interfaces through serial communication protocols. The ESP32, being a versatile microcontroller, is capable of processing the GPS data received from the module. The connection between the NEO-6M GPS module and the ESP32 involves wiring the module's TX (transmit) pin to the ESP32's designated RX (receive) pin, and vice versa. This ensures a two-way communication channel, enabling the microcontroller to receive location data from the GPS module. The ESP32 processes this incoming data, extracting relevant information such as real-time coordinates, time, and satellite information, utilizing libraries like TinyGPSPlus.h during the programming phase. The NEO-6M GPS module and ESP32 microcontroller collaborate through seamless serial communication, allowing for accurate and real-time GPS data acquisition. This integration empowers the project with the capability to track the live location of the vehicle, a fundamental component of the Smart Vehicle Tracking system. The latitude, longitude, and altitude data are sent to the mobile application, providing users with the ability to monitor the live location of the vehicle.

In the development of my accident detection system, we seamlessly integrated the MPU-6050, a versatile 6-axis gyroscope and accelerometer, with the ESP32 microcontroller. GY-521 MPU6050 gyroscope and accelerometer sensor can detect sudden changes in acceleration, orientation and angular velocity which is monitor by algorithm in program. As data cross limits in program accident will detects and system can then send an alert to the owner. The gyroscope measures the rate of rotation or angular velocity around multiple axes (typically three: X, Y, and Z). It does so by detecting changes in the Coriolis force, which is generated when the sensor experiences angular acceleration due to rotation. The accelerometer measures acceleration, including gravitational forces, along the same three axes (X, Y, and Z). It detects changes in linear acceleration in any direction. The physical setup involved a

meticulous wiring process, connecting the SDA and SCL pins of the MPU-6050 to the ESP32's D21 and D22 pins, respectively, for efficient I2C communication. Ensuring the appropriate VCC and GND connections completed the hardware configuration. Leveraging the Arduino IDE and essential libraries like Wire and MPU6050 streamlined the control and communication with the sensor[10].

The programming of the ESP32 entailed continuous acquisition of data from the MPU-6050, providing angular velocity and acceleration data along three axes. This raw data formed the foundation for calculating a comprehensive combined acceleration vector, a crucial aspect of the accident detection algorithm. The algorithm, tailored to meet the specific requirements, ranged from straightforward threshold-based approaches to accommodate the complexity of accident detection scenarios. Up on the detection of an accident, the ESP32 was programmed to trigger predefined actions, such as sending real-time notifications to the vehicle owner and activating alerts within a dedicated mobile application. This seamless integration of hardware and software components not only ensures the reliability and accuracy of the accident detection system but also highlights its sophistication and efficacy. Rigorous testing in diverse real-world scenarios validated the system's responsiveness to various accident scenarios, thereby enhancing safety measures in vehicular applications. The culmination of hardware precision, advanced algorithms, and seamless data communication underscores the pivotal role of this accident detection system in ensuring road safety.

RESULT

Utilizing a rigorous testing protocol, our cutting-edge ultrasonic sensors have been proven to deliver unparalleled accuracy in monitoring the intricate dynamics of fuel levels within the vehicle, showcasing their remarkable capability to discern minute fluctuations with precision and reliability (Figure 6).

Throughout the comprehensive testing phase, which rigorously evaluated system performance under various operational conditions, it was conclusively established that the initial fuel level of 56% steadily declined to 53%, thereby activating a series of timely alerts meticulously relayed through our dedicated mobile application (Figure 7). This seamless integration of advanced sensor technology and mobile application functionality empowers vehicle owners with proactive insights, enabling them to exercise informed decision-making and implement efficient management strategies to ensure optimal vehicle performance and resource utilization.

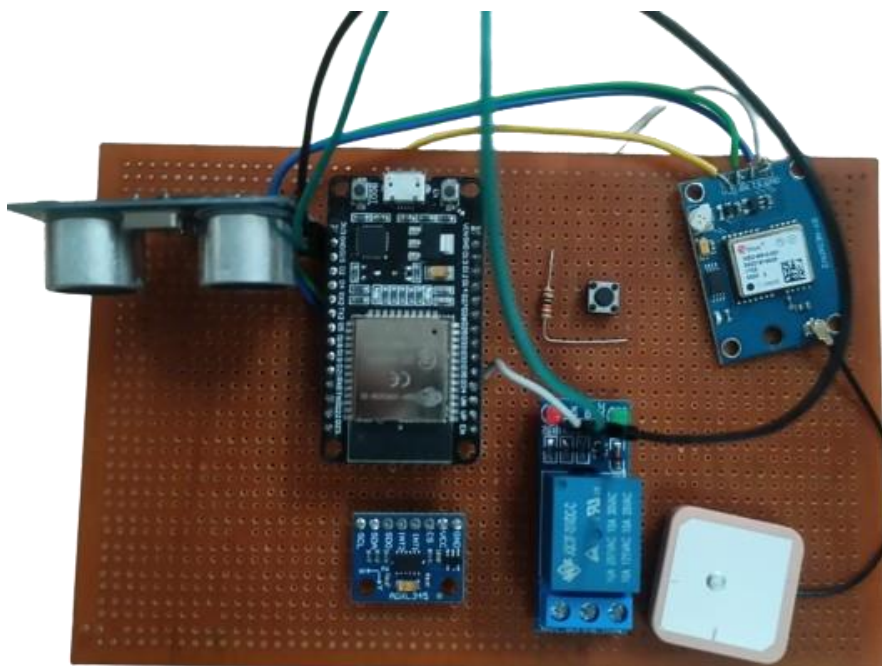

Figure 6. Ultrasonic sensors.

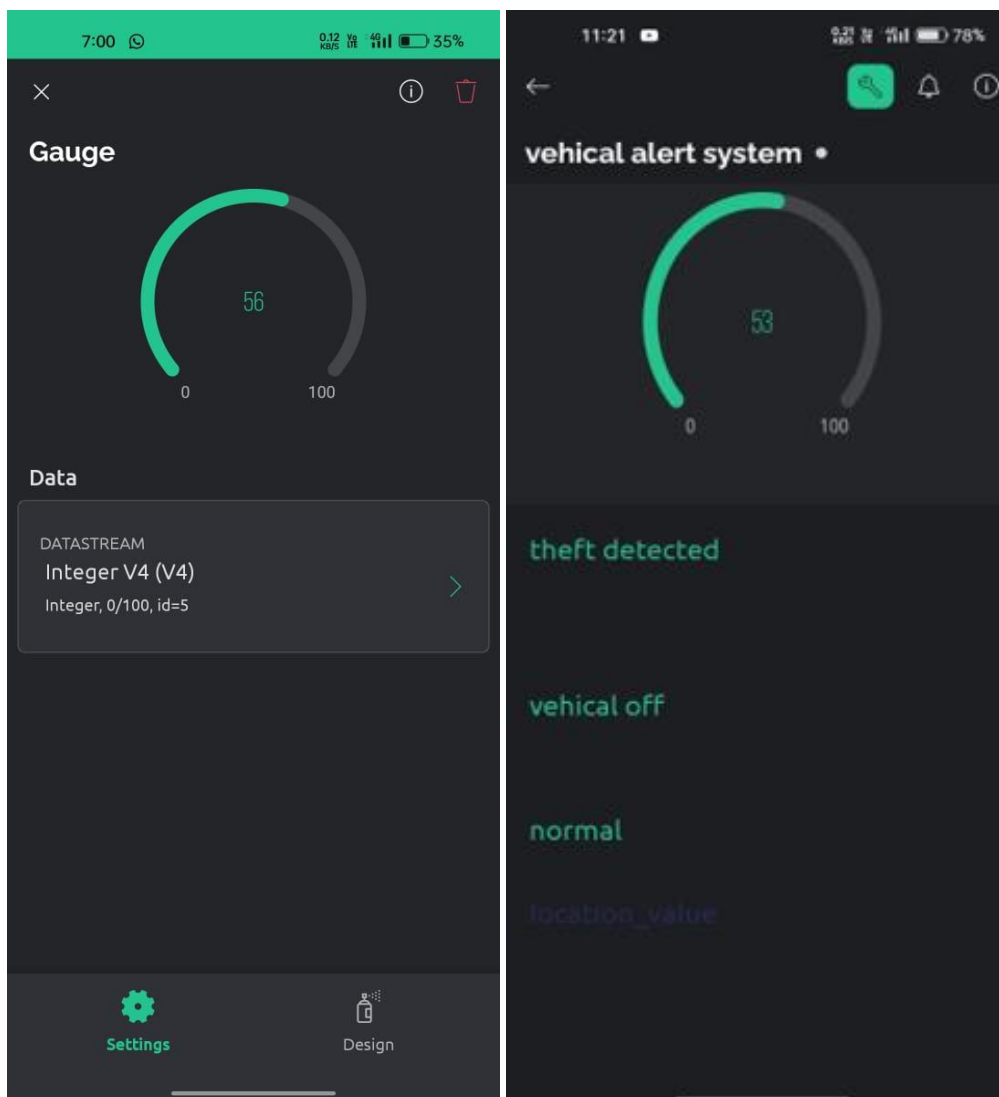

Figure 7. Timely alerts.

CONCLUSION

The envisioned project constitutes a multifaceted vehicle security and management system, seamlessly integrating live tracking, an anti-fuel theft mechanism, and accident detection. Leveraging GPS technology and the ESP32 microcontroller, the live tracking system enables real-time monitoring of vehicle locations, providing owners with a valuable tool for security and peace of mind. The anti-fuel theft system employs innovative sensors and monitoring techniques to detect irregular fuel consumption patterns, alerting owners to potential thefts and mitigating associated risks. Complementing this, the accident detection system, utilizing the MPU-6050 gyroscope and accelerometer, ensures swift response in emergency situations, triggering notifications and alerts within the dedicated mobile application. The centralized mobile application serves as a user-friendly interface, offering owners comprehensive control over their vehicles' security and enabling timely responses to potential threats or incidents. This holistic approach reflects a robust solution, combining advanced technologies for enhanced vehicle safety and management.

REFERENCES

1. Liu, Y., Li, X., Zhao, Y., & Han, Z. (2023). An Improved Vehicle Accident Detection Algorithm Based on Deep Learning and Vehicle Communication Technology. *IEEE Access*, 11, 39048–39058.

2. Sharma, A., & Saini, R. K. (2022). Intelligent Accident Detection and Tracking System Using IoT. In 2022 12th International Conference on Cloud Computing, Data Science & Engineering (Confluence) (pp. 367–371). IEEE.
3. Rathi, N., Kala, V. R., & Dubey, R. (2022). A Review on Advanced Vehicle Accident Detection System Using IoT. In 2022 6th International Conference on Intelligent Computing and Control Systems (ICICCS) (pp. 47–52). IEEE.
4. Zhu, Y., Yang, H., Li, C., & Chen, Y. (2023). Intelligent Vehicle Accident Detection and Tracking System Based on Big Data Analytics. In 2023 9th International Conference on Big Data Analytics (ICBDA) (pp. 359–363). IEEE.
5. Sharma, S., & Gupta, P. (2023). Smart Vehicle Tracking and Accident Detection System using Internet of Things. In 2023 3rd International Conference on Computing Methodologies and Communication (ICCMC) (pp. 504–509). IEEE.
6. Tiwari, A., & Mishra, A. (2022). Enhanced Vehicle Accident Detection System using Deep Learning and IoT. In 2022 International Conference on Inventive Computation Technologies (ICICT) (pp. 1–6). IEEE.
7. Patel, S. A., Patel, S. P., Adhyaru, Y. B. K., Maheshwari, S., Kumar, P., & Soni, M. (2022). Developing smart devices with automated Machine learning Approach: A review. *Materials Today: Proceedings*, 51, 826–831.
8. Kumar, K. S. R., Solanke, R. R., Laxmaiah, G., Alam, M. T., & Taluja, R. (2023, April). Iot and data mining techniques to detect and regulating of solar power system. In 2023 *International Conference on Inventive Computation Technologies (ICICT)* (pp. 1382–1385). IEEE.
9. De Carvalho, V. D. H., & Costa, A. P. C. S. (2023). Exploring Text Mining and Analytics for Applications in Public Security: An in-depth dive into a systematic literature review. *Socioecon. Anal*, 1, 5–55.
10. Collier, B. (2023). *Considerations for Selecting and Implementing Cloud Security Solutions Using Cloud Access Security Brokers* (Doctoral dissertation, Marymount University).