

Examining and Analyzing the Double Helical Spiral Mixer's Effectiveness

Kanchan.K. Makune*¹, I.I. Sayyad²

¹ *PG Student, Department of Mechanical Engineering, Sanjivani College of Engineering, India

² Assistant Professor, Department of Mechanical Engineering, Sanjivani College of Engineering, India

Corresponding author email id: ksmakune@gmail.com

Abstract:

Recent advancements in various mixing mechanisms are being leveraged in the food industry to enhance their success by ensuring product consistency fostering the development of new products and cutting down production costs the choice of mixing equipment is influenced by the types of phases being combined such as liquid-liquid solid-liquid or solid-solid and the physical properties of the final product including viscosity and density both traditional and innovative specialty mixing technologies are use in today but studies indicate that the efficiency of double helical mixers surpasses that of conventional mixers in traditional mixing methods metal oxide powder and vehicle are combined using a unidirectional stirring machine this machines stirrer rotates in a single direction creating a specific flow pattern in the fluids which causes particles to adhere to the container walls due to centrifugal force rather than mixing thoroughly in the paint mixture this results in a subpar quality of paint mixture and consequently a lower quality paint output to achieve homogeneous mixing it would be beneficial to have a stirrer shaft that rotates the blades in opposite directions with spiral blade applications in one cycle this would generate a turbulent flow pattern leading to an irregular flow pattern and a thoroughly mixed paint mixture ultimately producing high-quality paint additionally a pneumatic ram that dynamically moves the mixers drive head up and down would further enhance the mixing process.

KEY WORDS: Bidirectional motion, Periphery spiral blades rotation, Homogeneous mixture, pneumatic ram, Conical Screw Mixer.

1. INTRODUCTION

Combining powders of various materials to produce a uniform product or powder mixture is a relatively straightforward process. However, challenges emerge when attempting to mix powder in a fluid medium, particularly when the powder possesses a high density. The heavy particles tend to settle, necessitating the use of a bidirectional mixer designed to move in opposite directions within a single cycle. This motion is facilitated by a crank and fork mechanism, which generates turbulence and results in a homogeneous mixture. Mechanical mixers are extensively utilized in process industries such as chemical plants, food processing facilities, and the paint industry to mix powders and semisolid jelly fluids. Mixing involves the combination of powders or jellies into a uniform mixture, whereas stirring refers to the process of thoroughly dissolving powder in a fluid to achieve a consistent product. In both scenarios, thorough mixing is essential for producing a high-quality, uniform output. Mixing is a crucial step in transforming raw ingredients into consumable food, with consistency being a key objective shared by other food processing stages. In the food industry, maintaining consistency is vital not only from batch to batch but also across different facilities, as it underpins consumer loyalty [1-5].

Whether a recipe requires small-scale hand mixing or large-scale blending of multiple ingredients, both home cooks and process engineers recognize the importance of proper mixing Even when the right ingredients and flavors are used, a recipe will not produce desirable results without proper mixing. The blending process plays a vital role in determining taste, texture, color, and overall appearance. Consumers also expect consistency, wanting each product they purchase to match the quality and

characteristics of previous purchases. Selecting and using appropriate mixing equipment depends on the type of materials involved—whether liquid–liquid, solid–liquid, or solid–solid—as well as the physical properties of the final product, including its viscosity and density. In practice, many mixing technologies have overlapping uses and functions, allowing certain applications to be successfully produced by multiple types of mixing systems. In such situations, budget limitations may restrict the ability to invest in higher-cost equipment at the outset; however, efficiency differences must still be carefully evaluated. Choosing the right mixer and properly assessing its performance are essential steps in achieving an efficient and optimized process. After experimental analysis and study, the double helical spiral mixer is most effective and efficient for mixing all types of mixed ingredients [6-10].

1.1 Objectives

1. To design a screw mixer that delivers high efficiency and reduced processing time while accommodating a wide range of raw materials and particle sizes.
2. To develop a double helical spiral mixer suitable for diverse industries, including pigments, dyes, pharmaceuticals, chemicals, food, cosmetics, batteries, pesticides, construction materials, and plastic granule production.
3. To ensure the mixing operation is dependable and gentle, minimizing equipment wear and reducing maintenance requirements.
4. To evaluate its performance in comparison with a planetary horizontal mixer and a conical screw mixer, highlighting its lower energy usage and advantages for energy efficiency and environmental sustainability.

1.2 Types of Mixers

1.2.1 Conical Screw Mixer

A conical screw mixer is a vertical mixing system designed for efficient blending of powders and granules while consuming relatively low energy. It can handle materials with varying particle sizes effectively. The unit operates with screws and screw arms powered by a motor and gearbox, each moving at different speeds. The screws rotate on their own axes through a bevel gear mechanism, lifting material from the bottom of the vessel upward, after which it descends naturally under gravity (figure 1). Simultaneously, the screw arm rotates around the central shaft, promoting continuous movement and thorough circulation of materials throughout the mixing chamber.

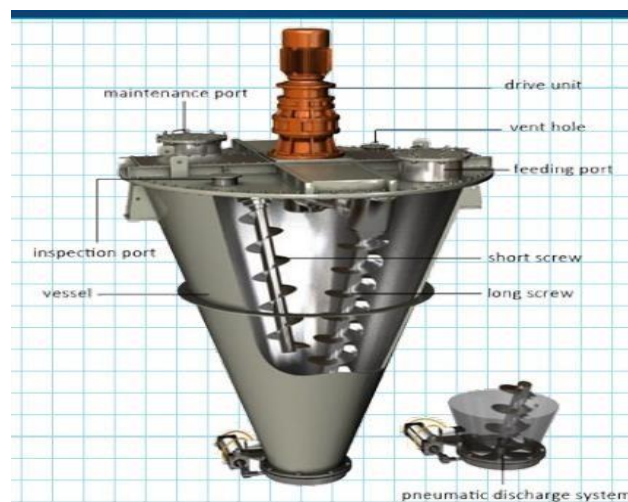

Fig.1: 2D View of Conical Screw Mixer

A three-dimensional action involving the entire mix wherein raw materials are sheared and diffused repeatedly in the vessel takes place. The mixture thus achieves optimum homogeneity.

1.2.1 Planetary Mixer

Selection of tooth counts for every gear in a planetary gear set must be made appropriately to ensure all the components into a properly connected (figure 2-3). After identifying the required design, the set has to be completed with other essential parameters to provide a functional system. For instance, one would need to specify a gear ratio of 5:1.

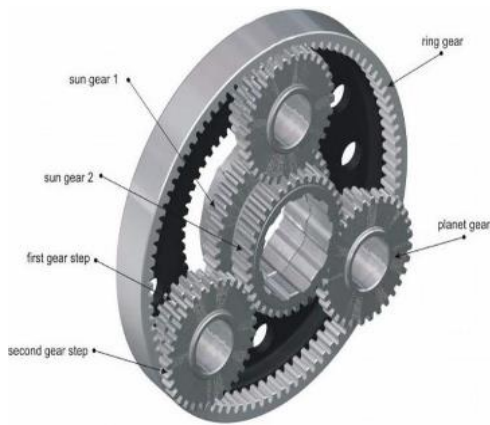

Fig.2: 2D View of Planetary Gear



Fig. 3: Planetary Mixer

In this configuration, the sun gear must complete five rotations for each single rotation of the output carrier. This assumes that the sun gear serves as the input, the planet gears transmit motion to drive the carrier as the output, and the ring gear remains stationary. Other arrangements can be used based on application). Another design limitation will have to be determined to complete the remaining calculations. Let the sun gear have 24 teeth.

By replacing the values we have discovered into the formula, we can conclude that the number of teeth required on the ring gear is 96. This allows us to determine how many teeth the planet gear has, which is expressed as N_p : number of teeth on the planet gear(s). By replacing the appropriate values, we can see that the number of teeth needed on the planet gear is 36. The actual number of planet gears is irrelevant to the problem. It must be noted that the actual pitch of the gears has not been determined yet. These equations are valid regardless of the pitch, though a specific pitch will have to be chosen at some point in the design process of a planetary gear system. The choice of pitch may either constrain the design, or the physical size constraints may dictate the pitch that can be implemented. A planetary gear system, also called an epicyclic gear train, is made up of three main components: a central sun gear, multiple planet gears that rotate around it, and an outer ring gear. Torque is transmitted from the sun gear to the surrounding planet gears, enabling the system to distribute motion efficiently. Both of these are housed within the boundaries of the ring gear. The tooth pattern of the sun and planet gears is of the external type, while the ring gear has an internal tooth pattern. Planetary gear sets are of wide variation in size and shape, allowing the production of a very broad range of speed ratios to meet varied design requirements. Planetary gear systems find applications across a wide spectrum, including clocks, lunar calendar mechanisms, automotive rearview mirrors, toys, geared motors, and turbine engines.

2. CONSTRUCTION AND WORKING OF DOUBLE HELICAL SPIRAL MIXER

A mixer is being designed that includes a container, spiral impeller blades, an electric motor, a set of pulleys, pedestal bearings, pneumatic rams, a timer, a solenoid valve, and drive shafts. We are using the container, which consists of stainless steel, and it is kept around 6 inches above the ground, so it is convenient to pour the material, prepare the chemical solution. A mixer is being designed to efficiently blend cleaning solutions used for floor maintenance. The system comprises a container, spiral impeller blades, an electric motor, a pulley set, pedestal bearings, pneumatic rams, a timer, a solenoid valve, and drive shafts. The motor is mounted vertically to align with the pulley and belt assembly on its shaft, ensuring smooth power transmission. Planetary gear systems, which include a central sun gear, orbiting planet gears, and an outer ring gear, are employed to distribute torque effectively. These gear sets find applications across a wide range of devices, from clocks and lunar calendar mechanisms to automotive rearview mirrors, toys, geared motors, and turbine engines. The choice of gear pitch may either constrain the design, or physical size limitations may dictate the pitch that can be implemented. In an electrically driven system, an electric motor is used to rotate the motor shaft. When the motor shaft is rotated, the pulley fitted on the motor shaft also rotates.

Power will be transmitted from the motor to the impeller shaft. When the impeller shaft starts rotating, the spiral impeller blades also rotate in the same direction at the same time. Parallel to this, the configurations of the pneumatic ram lift and lower the driver's head to achieve maximum efficiency in agitation, depending on the operation of the timer. Therefore, the mixing of chemical constituents is achieved. The theoretical model of a mixer and the functional working model is represented in Figure 4 and 5.

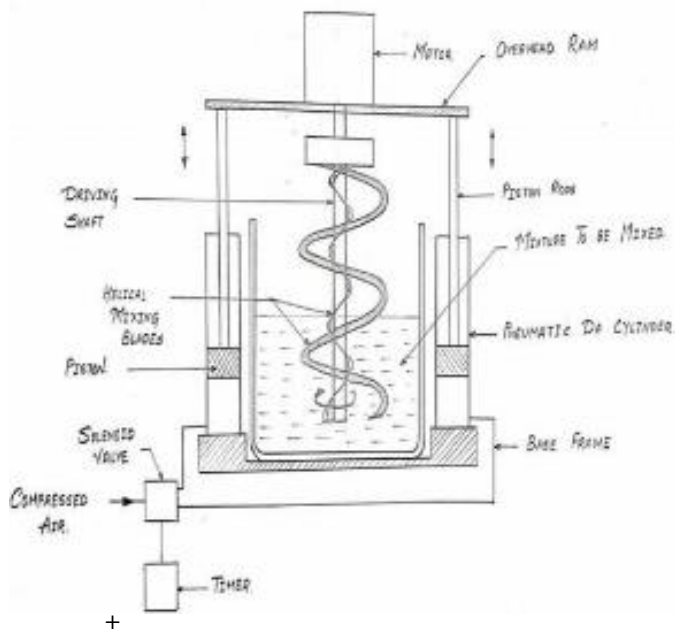

Fig.4: Proposed Model of Mixer



Fig.5: Real Model of Mix

2.1. Benefits and Constraints

2.1.1. Benefits

- 1) Optimal mixing homogeneity
- 2) Less mixing time compared with the conventional mixture.
- 3) Exceptional uniformity and quality in each batch of production.
- 4) Reduced wear and minimal maintenance requirements.
- 5) Easy access to a mixer/ Easy to clean.
- 6) Outstanding blending capabilities across all product tiers.
- 7) Low power consumption

2.1.2 Limitations

- 1) The machine we developed has a capacity of only 20 liters. Although it is not intended for full-scale production, it meets all the essential requirements. This prototype serves primarily to demonstrate the model's reliability and to test any functional changes during the development process.
- 2) The machine we developed has a small motor capacity, so it cannot handle a large quantity of chemicals or liquids.

2.2 Applications

1. Paint industry
2. Chemical Industry
3. Construction Material
4. Food Industry
5. Animal Feed
6. Metallurgy
7. Pharmaceutical Industry
8. Ceramic Powder
9. Mining Industry

Figure 6 showed the mixing of multiple color paint in the industry whereas figure 7 illustrate the Mixing of Metallic Powders in



Toothpaste, Gels, Ointments, etc.

Fig.6: Mixing of Multiple Color Paint in the Paint Industry



Fig.8: Mixing Applications in Pharmaceutical Industry



Pigment and figure 8 showed the Mixing Applications in Pharmaceutical Industry and figure 9 illustrate the Skimming Machine for Creams, Lotions,

Fig.7: Mixing of Metallic Powders in Pigment



Fig.9: Skimming Machine for Creams, Lotions, Toothpaste, Gels, Ointments, etc

3, RESULT

The test was conducted using three liquids with standard viscosity ranges (measured in centipoise). The procedure involved the Double Helical Spiral Mixer, and the time required for each test was recorded on both the old machine and the Double Helical Spiral Mixer. The results were then plotted for comparison.

3.1. Normal Viscosity Range

In the test of water and milk, adding 1 cps of water and 2 cps of milk, and taking a reading for both the old and new mixers (figure 10).

Water = 1cps
 Milk = 3cps
 Take milk = 2cps
 cps = centi-poise

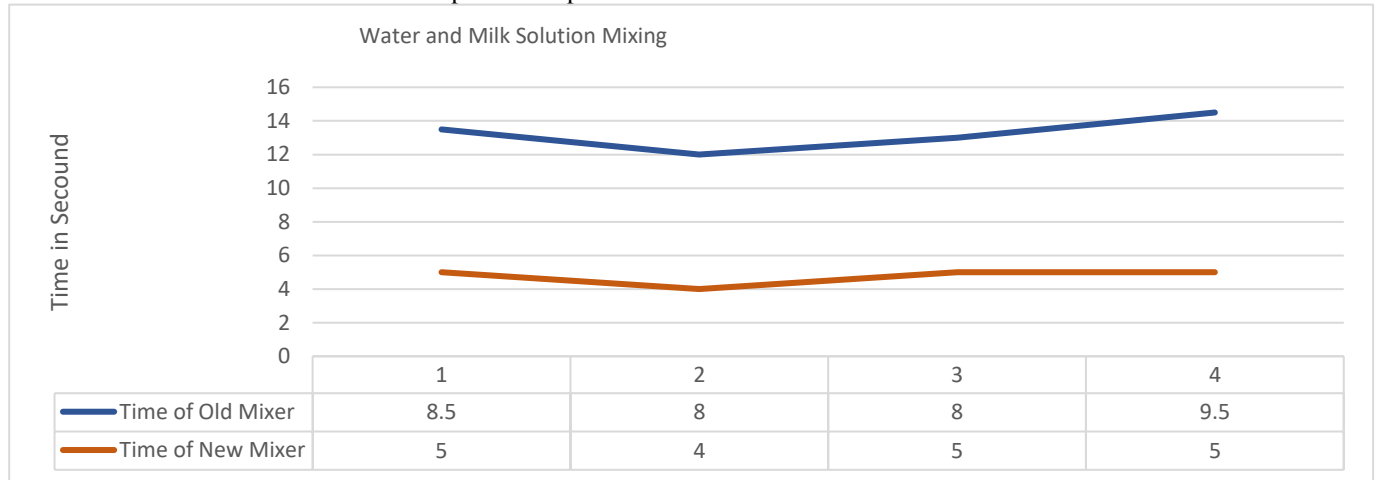

Fig 10: Required Time to Maintain Viscosity of Milk Up to 2 cps

From the above analysis of graphs, we can see that the time for effective mixing of milk and water is much shorter, about 14% shorter, in all the tests that were performed, than the older model mixer.

3.2. Normal Viscosity Range for water and ink

In the test of water and ink, adding 1 cps of water and 500 cps of ink, and taking a reading for both the old and new mixers (figure 11).

Water = 1cps
 Ink = 550-2200cps
 Take ink = 500cps

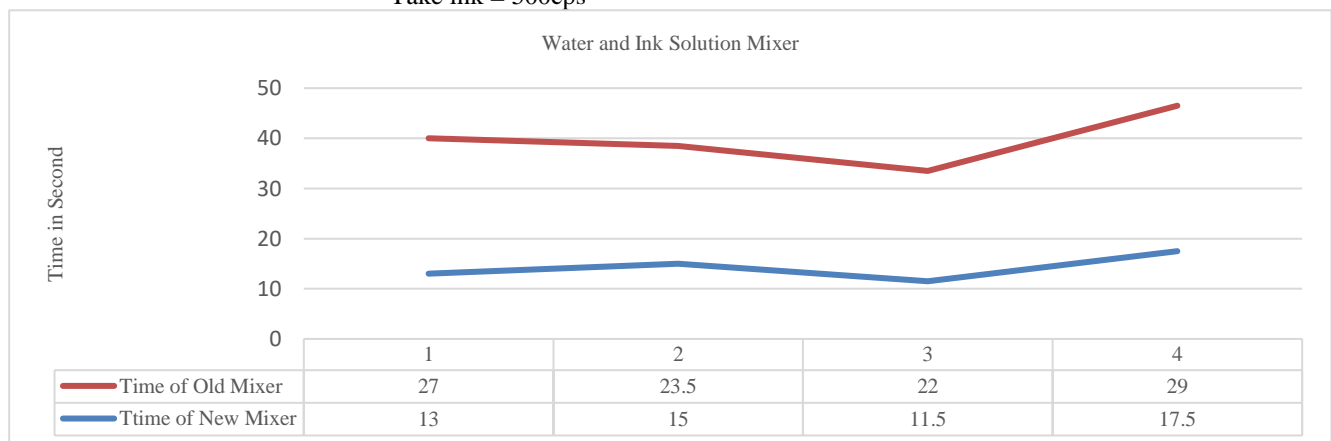

Fig.11: Required Time to Maintain Viscosity of Ink up to 500 cps

From the above analysis of graphs, we can see that the time for effective mixing of milk and ink is much shorter, about 44% shorter, in all the tests that were performed, than the older model mixer

3.3. Normal Viscosity Range for water and soap solution

In the test of water and milk, adding 1 cps of water and 40 cps of soap solution, and taking a reading for both the old and new mixers (figure 12).

Water = 1cps
 Soap solution = 82cps
 Take soap solution = 40 cps

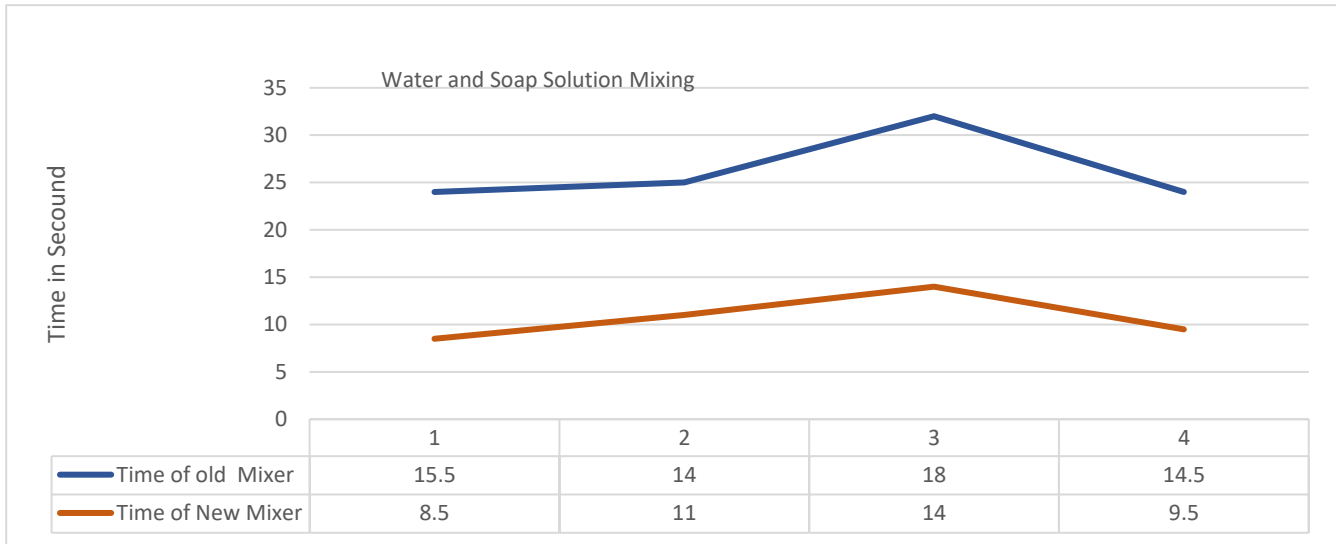

Fig. 12: Required Time to Maintain Viscosity of Soap Solution up to 40cps

From the above analysis of graphs, we can see that the time for effective mixing of soap solution and water is much shorter, about 19 % shorter, in all the tests that were performed, than the older model mixer.

Testing Comparison of all Three Different Mixtures results are given in Table 1.

Sr. No	Type of Mixer Used	Mixing 1cps water and 2cps Milk				Mixing 1cps water and 500cps ink				Mixing 1 cps of water and 40 cps of soap Solution.			
		Test 1	Test 2	Test 3	Test 4	Test1	Test 2	Test 3	Test 4	Test1	Test 2	Test 3	Test 4
1	Old Mixture Time (Sec)	9	8.5	11	8.5	27	23.5	22	29	15.5	14	18	14.5
2	New Mixer Time (sec)	5	4	5	5	13	15	11.5	17.5	8.5	11	14	9.5
3	Time Effectiveness (%)	14%				44%				19%			

Table 1: Testing Comparison of all Three Different Mixtures

4. Conclusion:

This mixer uses two helical spiral blades for mixing, it takes less time to mix than other mixer types. The model we developed employed a 20-liter capacity with a 60-rpm motor. Mixing liquid and semisolid products is done with this mixer.

These models achieve the necessary goals of minimizing the time and human effort involved in mixing procedures. In a similar vein, it keeps the chemical mixing procedure accurate. With high-speed chemical mixing in all kinds of liquids, it carried out the most rigorous operation. Create an automation unit for the mixer after making particular modifications to this equipment so that it can be readily incorporated into today's automated facilities.

5. References

1. Dr. Schulze T., Prof. Hartmann C. Prof. Dr. Schlecht B., "Calculation Of Load Distribution In Planetary Gears For An Effective Gear Design Process", American Gear Manufacturers Association 500 Montgomery Street, Suite 350 Alexandria, Virginia, 22314, October 2010, Isbn: 978--1--55589--983—7.
2. Ferraris, C.F., "Concrete Mixing Methods and Concrete Mixers: State of the Art", Journal of Research of the National Institute of Standards and Technology, Vol. 106, No. 2, 391-399 (2001).
3. Siddhant Dange, Saket Sant, Anish Sali, Parthon Pethodam, Sandeep Belgamwar., "Study of planetary concrete mixer", International journal of latest research in engineering and technology, ISSN 2454- 5031, Volume 2, Issue 4, April 2016.
4. Thompson Aguheva, "Design and Fabrication of an Industrial Mixer", International Journal of Practices and Technologies, ISSN 1583-1078, Issue 20, January- June 2012.
5. Kulat P. S., Chadge R.B., 3d Motion Mixer For Material, International Journal Of Pure And Applied Research In Engineering And Technology Path For Horizing Your Innovative Work Research Article Impact Factor: 0.621 : 231 Isbn :9-507xps Kulat, Ijpret, 2014; Volume 2 (9): 97-102 Ijpret.
6. Chao Chen, The Design Of Innovative Epicyclic Mechanical Transmissions: Application To The Drives Of Wheeled Mobile Robots, Published Heritage Branch Direction Du Patrimoine De L'édition 395 Wellington Street Ottawa On K1a On4 Canada Isbn: 978-0-494-25114-0.
7. Ming Jin Yang, Xi Wen Li, Tie Lin Shi, Shu Zi Yang, Performance Analysis And Parameter Optimization Of A Planetary Mixer Applied Mechanics And Materials, 37-38, 858, November 2010
8. Ming Jin Yang Et Al. Modeling And Stability Analysis Of The Speed Regulating System Of A Planetary Mixer, Advanced Materials Research (Volumes 354 - 355), October 2011.
9. J. Dils, G. De Schutter and V. Boel, Influence of mixing procedure and mixer type on fresh and hardened properties of concrete: a review, Materials and Structures (2012), 10 May 2012, 1673–1683.
10. D. S. Dickey And J. B. Fasano, Mechanical Design Of Mixing Equipment, In Edward L. Paul (Ed), Handbook Of Industrial Mixing : Science And Practice, (Published By John Wiley & Sons, Inc., Hoboken, New Jersey, 2004), 1247-1332.