

# KSK-approach to Smart Agriculture: Utilizing AI-driven Internet of Things

Kazi Kutubuddin Sayyad Liyakat\*

## Abstract

*An enormous change is taking place in the agriculture industry as a consequence of the arrival of the AI IoT, which is powered by artificial intelligence and provides farmers with unparalleled automation capabilities and insights. This research determines to present an all-inclusive review of artificial intelligence and the Internet of Things (AI IoT) in smart agriculture, focusing on its applications, benefits, and consequences for decision-making. The concept of smart agricultural decision-making refers to a breakthrough method that enables farmers to augment their farm maneuvers while also making well-informed judgments. Farmers can increase crop yields while simultaneously reducing costs and hazards when they make use of advanced analytics, real-time info, and decision-making tools. The development of smart agriculture will result in farmers having increased decision-making authority, which will ultimately lead to an agricultural sector that is more maintainable and productive. The Internet of Things (IoT) and artificial intelligence (AI) in smart agriculture is a cutting-edge technology that has the potential to be a game-changer in terms of how to harvest and consume food. Agriculturalists may be able to improve agricultural yields and quality, streamline operations, and contribute to a food supply chain that is more efficient and sustainable if they use AI and IoT. In spite of the fact that there are still certain problems that need to be cleared up, the IoT offers numerous advantages for smart agriculture, and its implementation is anticipated to increase in the years to come. The KSK technique, also known as the Knowledge-Sensors-Knowledge approach, is a suggestion made by Dr. Kutubuddin S. Kazi, who is also using his name. The output of the KSK technique results in an accuracy of 99.9% and a recall of 97.9%, respectively.*

**Keywords:** AI IoT, KSK-approach, humidity sensor, smart agriculture, Internet of Things, artificial intelligence

## INTRODUCTION

Technology is an area that is constantly evolving, and the agricultural industry is not left behind in this regard. Food production has been undergoing a revolution as a consequence of the enactment of smart agriculture, which encompasses the incorporation of cutting-edge technology into farming methods. The purpose of this study is to explore the many facets of smart agriculture, including its advantages and the degree to which it has the impending ability to transmute the agricultural sector [1–6].

### \*Author for Correspondence

Kazi Kutubuddin Sayyad Liyakat  
E-mail: drkkazi@gmail.com

Professor & Head, Department of Electronic & Telecommunication Engineering, Brahmdevdada Mane Institute of Technology, Solapur, Maharashtra, India

Received Date: September 10, 2024  
Accepted Date: September 13, 2024  
Published Date: September 18, 2024

**Citation:** Kazi Kutubuddin Sayyad Liyakat. KSK-approach to Smart Agriculture: Utilizing AI-driven Internet of Things. Journal of Microcontroller Engineering and Applications. 2024; 11(3): 21–32p.

IoT, AI, and Big Data are cutting-edge tools that are essential for the implementation of smart agriculture. These technologies are utilized to collect, analyze, and interpret data from diverse sources, including soil sensors, meteorological information, and satellite photos. We used this

---

information to make informed judgments about a variety of topics, including crop management, irrigation, and pest control [7, 8].

The capacity of smart agriculture to boost crop yield is one of the most significant advantages of this method. The utilization of data-driven insights enables farmers to optimize their plant management practices, which ultimately results in healthier plants and greater yields. This is of utmost significance in a world where the demand for nourishment continues to rise as a result of population expansion [9].

One additional advantage of smart agriculture is that it can lessen the negative effects of farming on the environment. By utilizing practices associated with precision agriculture, farmers have the potential to reduce their consumption of water, nutrients, and pesticides, thereby lowering the environmental impact of their activities. Climate change and environmental degradation are among the most pressing concerns worldwide, and this is of utmost importance [10, 11].

Additionally, it is possible that smart agriculture can enhance the standard of living of farmers. Farmers can raise their mean rate of living and boost their profitability by raising crop yields while lowering input costs. In addition, the utilization of technology has the potential to assist adolescents in the agriculture industry, which is currently experiencing a shortage of proficient laborers [12, 13].

It is important to note that the employment of smart agriculture is not difficult. The initial investment in technology may be rather substantial, and there may be a learning curve for farmers who are not familiar with the processes involved in the utilization of advanced technologies. There are concerns regarding the privacy and security of data, in addition to the likelihood that automation will result in the replacement of jobs [14–19].

Considering the current situation, smart agriculture is a significant step forward in the agriculture sector. It is possible for farmers to enhance their livelihoods, raise agricultural yields, and reduce their influence on the environment if they use increasingly advanced technologies. Despite the fact that there are obstacles to overcome, the potential advantages of smart agriculture render it an investment worth making for the further development of agriculture [20].

## **DECISION-MAKING (KSK-APPROACH) IN SMART AGRICULTURE**

The arena of smart agriculture is intensifying at a hasty rate, making use of cutting-edge technologies to improve crop yields and optimize agricultural operations. The KSK-approach to decision-making is an essential component of smart agriculture because it enables agriculturalists to make informed decisions based on real-time data as well as predictive analytics. The purpose of this learning is to provide an all-inclusive analysis of decision-making within smart agriculture by investigating important ideas, approaches, and applications [21–25]. One of the authors, Dr. Kutubuddin S. Kazi, proposed the KSK method.

- *Effective decision-making* for smart agriculture depends on the accessibility of timely and precise information. This is accomplished through the collection and integration of data. Many sensors and IoT devices are used to collect data on soil conditions, crop health, weather, and other pertinent information. It is possible to achieve a comprehensive understanding of the farming system by utilizing data integration platforms, which allow for the seamless amalgamation of data from a variety of sources [26].
- *Data analytics and modeling*: Once data has been acquired, this information is subjected to a variety of analytics and modeling approaches to derive useful insights. This is accomplished by utilizing machine learning algorithms, statistical models, and predictive analytics to recognize patterns, forecast crop yields, and optimize inputs. The knowledge that these models provide for farmers is extremely helpful in guiding their decision-making [27].
- *Decision support systems* are software tools that assist farmers in the process of making decisions based on accurate information. DSSs aim to combine data analytics and modeling with user

interfaces to deliver individualized recommendations tailored to the detailed circumstances of the farmer. They give farmers the ability to examine different possibilities, consider trade-offs, and finally make optimal decisions [28].

For decision-making purposes, Kazi developed a more recent approach. This method is referred to as the KSK technique. This technique is the most suitable option for any kind of decision-making system. Additionally, to ensure the safety of the IoT framework, they suggested a method referred to as the KK strategy for Internet of Things security [29].

A wide variety of applications can be found for decision-making in smart agriculture, including the following.

- Crop management involves optimizing irrigation schedules, fertilization tactics, and pest control procedures to achieve the highest possible rates of crop yield.
- Resource allocation refers to the process of effectively distributing resources, such as water, fertilizers, and labor, using data collected in real-time.
- The process of classifying possible risks and developing mitigation procedures to avoid financial losses is referred to as risk management.
- Supply Chain Management: Increasing the level of coordination and collaboration within the agricultural supply chain to improve both efficiency and responsiveness to various market conditions.

There are still a number of obstacles to overcome in smart agriculture, notwithstanding the progress made in decision-making.

- *Data quality and reliability*: It is essential for efficient decision-making to guarantee the appropriateness and dependability of data compiled from sensors and IoT devices.
- *Model development and validation*: The process of developing and validating models that are accurate and resilient to develop predictive analytics and make decisions is a continuing problem.
- *User adoption and training*: For widespread adoption, it is crucial to provide farmers with the expertise and abilities necessary to make good use of decision support systems.

The decision-making-KSK technique in smart agriculture is a game-changing instrument that gives agriculturalists the ability to make well-versed decisions and improve the efficiency of operations. Through the utilization of decision support systems, sophisticated analytics, and real-time data, farmers can increase crop yields, reduce costs, and limit hazards. The capacity of farmers to make decisions will continue to improve as the field of smart agriculture grows in importance, ultimately resulting in an agricultural sector that is more sustainable and productive [30].

### **Proposed Methodology**

Generally, referred to as AI IoT, the combination of AI and IoT in the agricultural industry has been a game-changer in the arena of smart agriculture. Through the implementation of this cutting-edge technology, agriculturalists have been able to significantly improve their management of crops, livestock, and farm operations, resulting in enhanced efficiency, production, and sustainability [31–35]. The planned AI-driven IoT infrastructure for smart agriculture is illustrated in Figure 1.

The proposed system is divided into three sections: IoT, cloud, and artificial intelligence decision-making components. Using NodeMCU, each sensor was connected to the IoT section. Every piece of data gathered from the farm, including temperature, humidity, and wetness, is connected to the IoT section using a NodeMCU.

To facilitate operations and analysis, such data are saved and uploaded to the cloud, where they will be accessed anytime, they are required. Within the framework of the KSK method for decision-making, we advocated the utilization of ANN, DT, and K-NN classifiers.

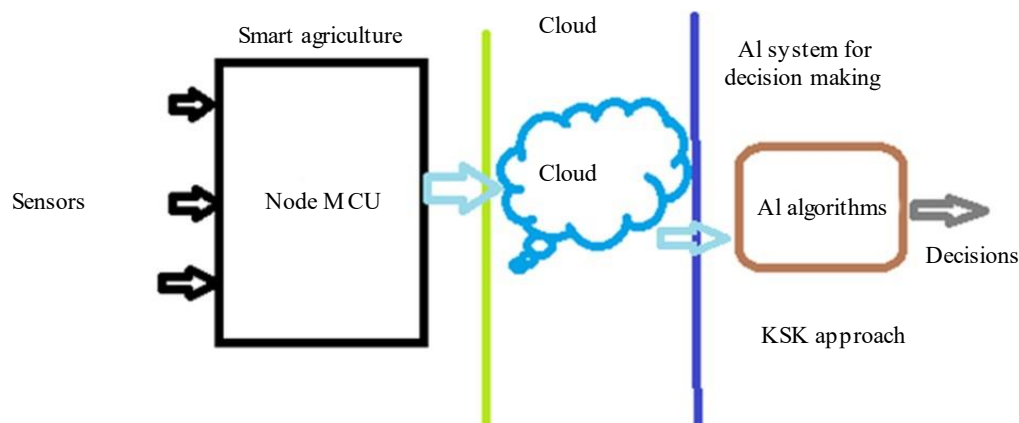

**Figure 1.** Proposed KSK-approach using AI IoT grounded smart agriculture system.

When the KSK technique is completed, higher values of all classifiers are produced. The results are reported in terms of accuracy and recall of information [36–40].

Artificial intelligence-driven Internet of Things (AI IoT) in smart agriculture is a comprehensive system that collects real-time data on many aspects of agribusiness, such as temperature, humidity, soil moisture, and crop health, by employing sensors, drones, and other IoT devices. AI algorithms were used to analyze these data, and the results provided farmers with useful insights and recommendations. This enables farmers to make decisions based on accurate information and to improve their tactics.

Among the most noteworthy advantages of the AI IoT in smart agriculture is its capacity to enhance both the quantity and quality of crop production. Farmers can change their irrigation and fertilization procedures in accordance with the soil conditions and the weather patterns that they observe. This allows them to guarantee that their crops receive appropriate amounts of water and nutrients. This not only results in increased yields but also reduces the negative impact of farming on the environment by reducing the amount of water that is wasted and preventing excessive fertilization.

A significant part of the IoT is played by animal farming, in addition to crop management. Through the use of IoT devices, GPS trackers, and health monitors, farmers can monitor the location, health, and overall well-being of their animals. Therefore, they can identify and handle any potential health problems at an early stage, thereby lowering the risk of disease epidemics and enhancing the general welfare of the entire population.

In addition, the application of AI IoT in smart agriculture has the potential to revolutionize how agriculturalists handle their property. AI algorithms have the potential to provide farmers with useful information regarding the timing of planting, harvesting, and selling crops. These insights can be obtained by evaluating the data on crop yields, weather patterns, and market trends. Not only does this assist farmers in optimizing their operations, but it also contributes to a food supply chain that is more stable and efficient.

IoT in smart agriculture has several opportunities for improvement; nevertheless, some obstacles must be overcome. The primary problem is the high expense and complexity involved in implementing these technologies, particularly for farmers working on a smaller scale. Concerns have also been raised regarding the privacy and security of personally identifiable information, as the gathering and evaluation of sensitive farming data might be exploited [41–45].

To summarize, IoT in smart agriculture is a revolutionary piece of machinery that has the impending to revolutionize how we grow and eat food. Farmers can optimize their operations, boost crop yields with quality, and contribute to a food supply chain that is more sustainable and efficient when they

leverage the potential of AI and IoT. The advantages of AI and IoT in smart agriculture are indisputable, and its implementation will likely endure an increase in years to come, even though there are still some obstacles to overcome.

Individual Components Necessary for an Intelligent Agriculture System:

- NodeMCU-2
- 4 channel ADC
- DHT11
- Moisture sensor

Connecting with others and experimenting with new things

- After you have created all the connections, you are required to upload the code.
- All of the soil moisture sensors Vccs should have the NodeMCU Vin attached to them.
- NodeMCU Vin should be connected to Multiplexer Vcc. The GND of the ADC multiplexer should be connected to NodeMCU GND. In addition, the ground of all other soil moisture sensors should be connected to the NodeMCU GND. The multiplexer was linked via the output from the soil moisture sensor, as shown in Figure 2.
- Figure 3 illustrates how to connect additional sensors to NodeMCU, such as those that measure temperature and humidity.
- Connect it to the DHT 11 output pin of the NodeMCU d3 device.
- The output from the soil moisture sensor is linked to A0. Additionally, NodeMCU Vin is connected to DHT 11 Vcc.
- Establish a connection between NodeMCU GND and DHT 11 GND.

## RESULTS AND DISCUSSION

Once the connections are completed, as depicted in Figures 2 and 3, the link transfers the specified code (Figure 4) to the NodeMCU service. The first step was to establish the Thing Speak Channel of the IoT-based Smart Agriculture system. Figure 5 illustrates how the output of the sensors was shown on the constructed channel.

Reliant on the information obtained from an IoT-based smart agriculture system connected to an AI system to make judgments. As a result, we continue to suggest a strategy referred to as the KSK-approach. This technique will be responsible for making judgments, and the activities advised to the user farmer will also be dependent on these decisions. Either watering, fertilizing, or other options are available.

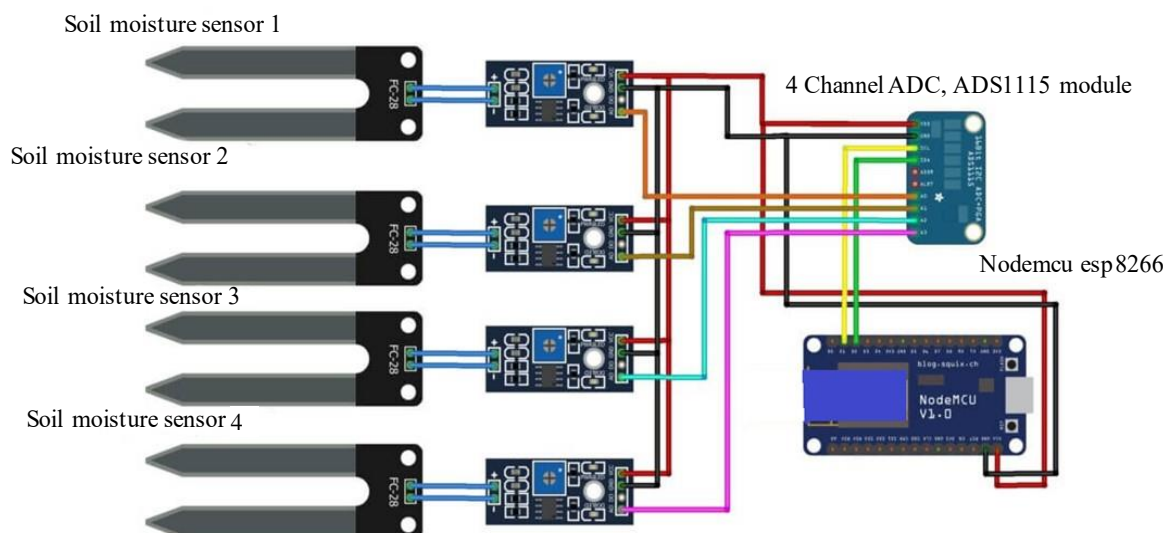

**Figure 2.** Soil moisture sensor assembly.

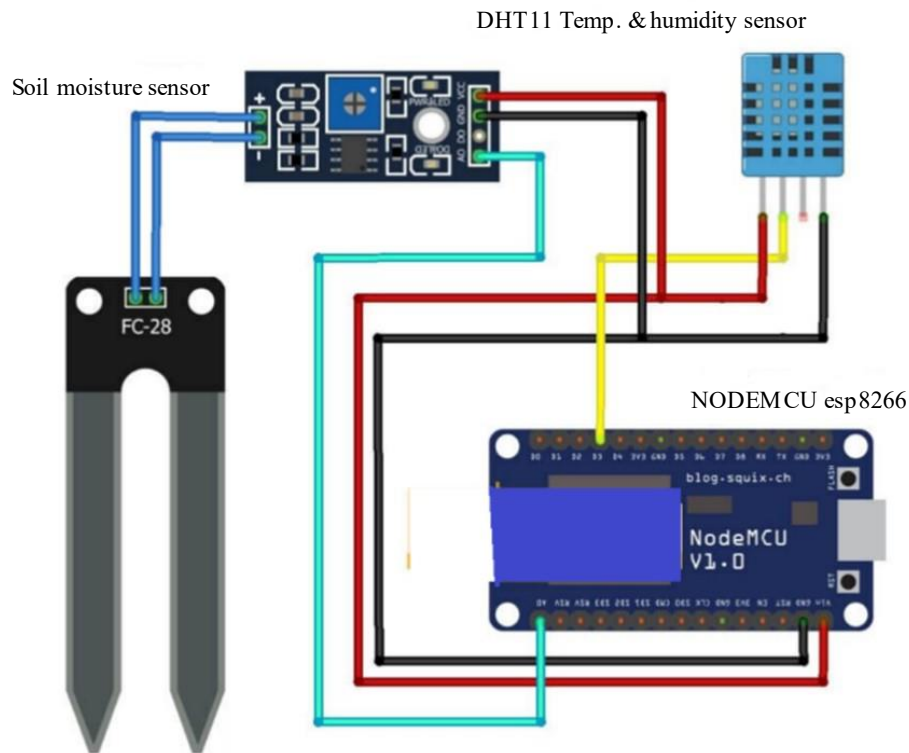

**Figure 3.** Sensors are associated with NodeMCU.

```
#include <ESP8266WiFi.h>
#include <ESP8266HTTPClient.h>
#include <Adafruit_ADS1015.h>
WiFiClient client;
String thingSpeakAddress= "http://api.thingspeak.com/update?";
String writeAPIKey;
String tsfield1Name;
String request_string;
HTTPClient http;
  Adafruit_ADS1115 ads;
void setup()
{
  Serial.begin(115200);
  delay(3000);
  WiFi.disconnect();
  Serial.println("START");
  WiFi.begin("DESKTOP","asdfghjkl"); // Wifi ("ID","Password")
  while ((!(WiFi.status() == WL_CONNECTED))){
    delay(300);
    Serial.println("...");
  }
```

**Figure 4.** NodeMCU code.

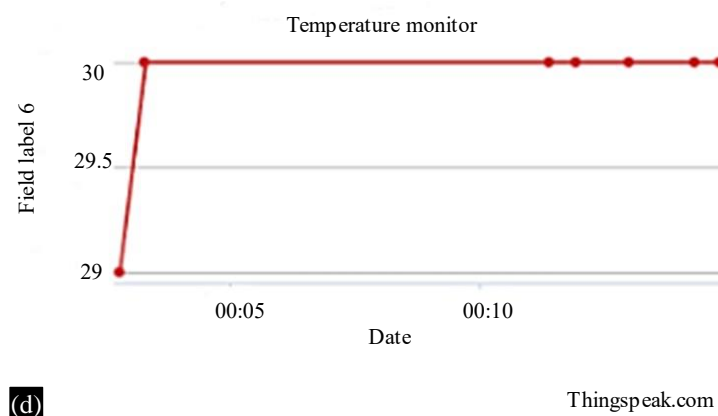
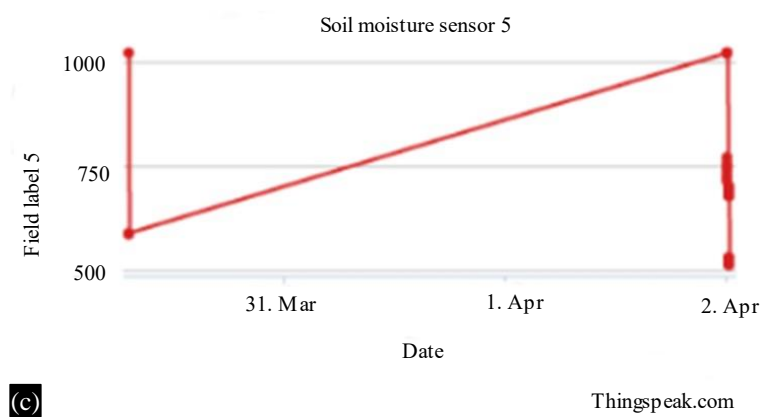
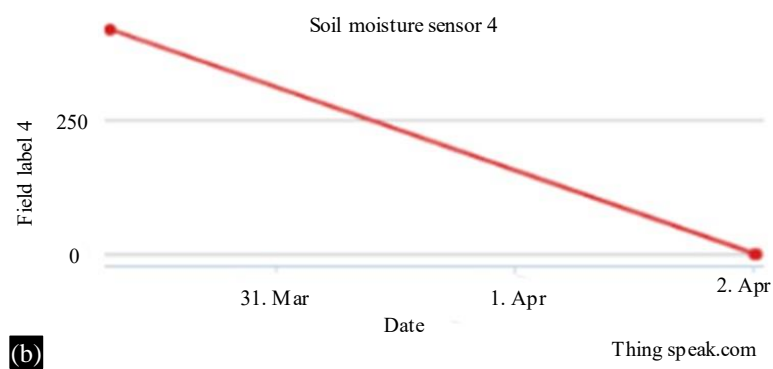
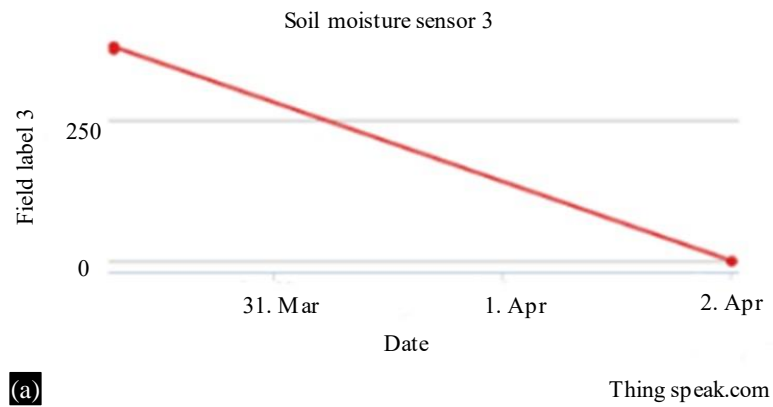

**Figure 5.** System output.

Smart agriculture uses AI and IoT to revolutionize conventional farming methods, thus boosting productivity, sustainability, and profitability. Smart agriculture, which makes use of AI and IoT, is turning farming into a revolution by giving farmers unparalleled insights and control over their operations. With the custom of AI algorithms and sensors connected to the IoT, farmers can maximize crop production, decrease waste, improve sustainability, and ultimately boost their profitability and resilience. As technological advancements continue, it is anticipated that artificial intelligence and the Internet of Things will play an increasingly significant role in establishing the future of agriculture and ensuring the safety of food supplies for a growing population. The use of AI and IoT in agriculture has the potential to transform the agricultural industry completely. Using AI algorithms and sensors connected to IoT, farmers may improve their operations, increase their sustainability, and satisfy the ever-increasing need for food. It is vital to address concerns linked to data privacy and the digital divide to guarantee the equitable adoption of AI IoT in agriculture and to ensure that it will have a revolutionary impact.

The following is a list of some of the key advantages of employing the AI IoT in smart agriculture:

- **Crop Monitoring and Optimization:** Sensors analyze the conditions of the soil and plant health, including weather patterns, offering agriculturalists real-time data that makes it possible for them to make knowledgeable decisions concerning fertilization, irrigation, and pest management.
- **AI algorithms analyze the information collected by sensors to identify the ideal timing and dosage for agricultural inputs, thereby minimizing waste and environmental effects. This is referred to as precision farming and uses artificial intelligence.**
- **Prediction of production:** Machine learning models make predictions about future production depending on past data and present conditions. This gives farmers the ability to plan and change operations accordingly.
- **AI IoT solutions monitor water and energy consumption, effectively maximizing their utilization and minimizing waste. This will contribute to resource conservation.**
- **To guarantee transparency and traceability throughout the supply chain, sensors monitor crop growth and harvest history. This helps to ensure that food is safe to consume.**

The results obtained using the KSK method are shown in Figure 7. In Figure 6, the results of the ANN, DT, and K-NN algorithms are shown in terms of their accuracy and recall. As can be seen in Figure 6, ANN offers a greater accuracy of 99.9%, whereas DT has a higher recall of approximately 97.9%. Consequently, the outputs of the KSK technique in terms of accuracy and recall were 99.9% and 97.9%, respectively.

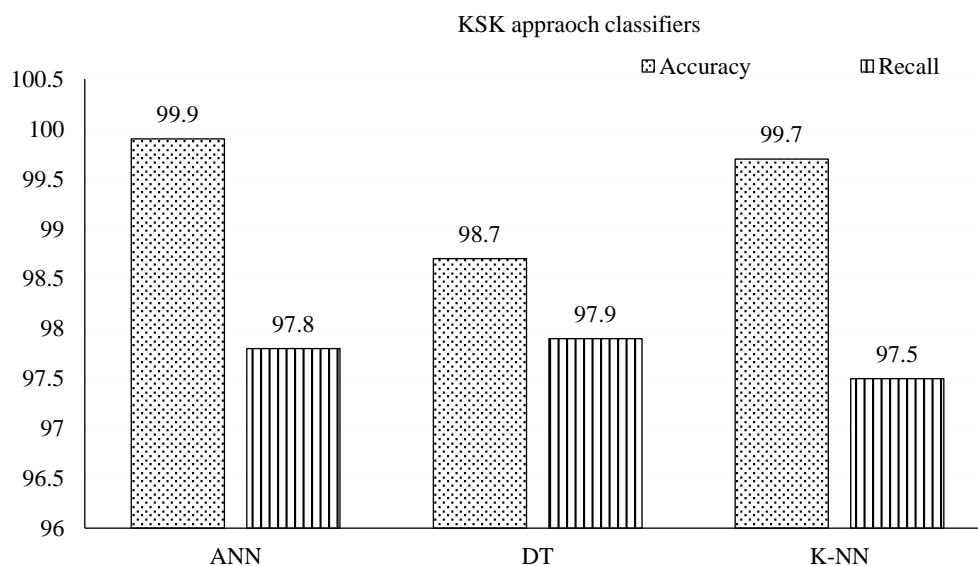

**Figure 6.** KSK-approach classifiers.

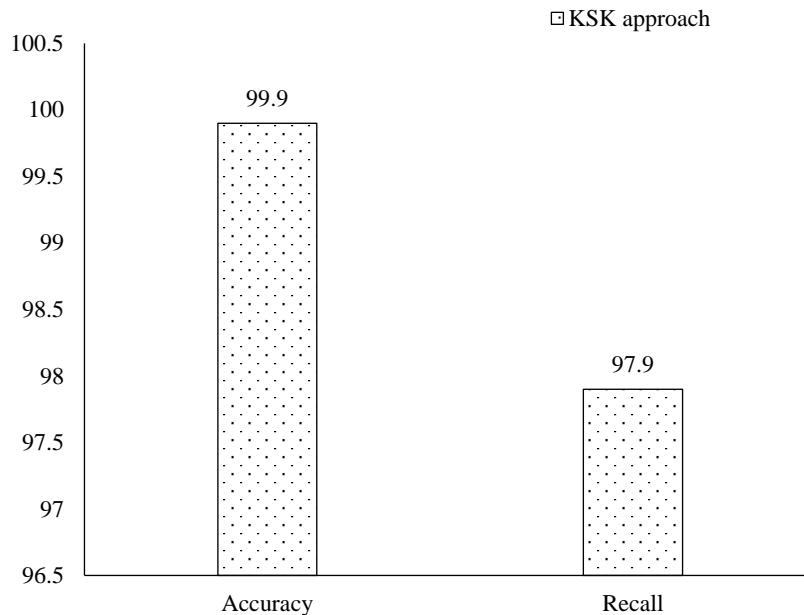

**Figure 7.** KSK-Approach output.

## CONCLUSION

Agricultural production faces a multitude of obstacles, such as climate change, population increase, and adverse environmental conditions. Transformative solutions are presented in smart agriculture, which makes use of the confluence of AI, IoT, and other sophisticated technologies. Artificial intelligence-driven Internet of Things, also known as AI IoT, has emerged as a disruptive force in the agricultural industry. This technology provides farmers with access to insights and automation capabilities that were previously unimaginable. This study intends to provide a comprehensive evaluation of the IoT in smart agriculture, with a particular emphasis on its applications, benefits, and implications for decision-making through the use of the KSK methodology. To enable farmers to make decisions that are well-informed and maximize their operations, smart agriculture makes use of decision-making as a transformative instrument. Through the utilization of real-time data, the application of sophisticated analytics, and the implementation of decision support systems, farmers have the potential to increase crop yields, decrease expenses, and reduce risks. As the technology of smart agriculture continues to evolve, farmers will become more sophisticated in their ability to make decisions, ultimately leading to a more productive and sustainable agricultural sector. IoT in smart agriculture is an advanced technology that has the potential to drastically transform how people cultivate and prepare food. Using AI and IoT, farmers may improve the efficiency of their processes, increase crop yields and quality, and contribute to a food supply chain that is more efficient and sustainable. The advantages of AI and IoT in smart agriculture are still incontestable, and the acceptance of this technology is set to continue growing in years, despite the fact that some challenges need to be resolved. The precision of the KSK technique is satisfactory compared with that of other cutting-edge technologies. The KSK strategy had an accuracy of 99.9%, whereas the recall method had an accuracy of 97.9%.

## REFERENCES

1. Liyakat KKS. Machine learning approach using artificial neural networks to detect malicious nodes in IoT networks. In: Shukla PK, Mittal H, Engelbrecht A, editors. *Computer Vision and Robotics: Proceedings of CVR 2023*. Springer Nature Singapore; 2023. p. 27–37. DOI: 10.1007/978-981-99-4577-1\_3.
2. Pradeepa M, Jamberi K, Sajith S, Bai MR, Prakash A, Kutubuddin Sayyad Liyakat Kazi. *IEEE 2nd Mysore Sub Section International Conference (MysuruCon)*, Mysuru, India; 2022. p. 1–5. DOI: 10.1109/MysuruCon55714.2022.9972445.

3. Liyakat KKS. Detecting malicious nodes in IoT networks using machine learning and artificial neural networks. International Conference on Emerging Smart Computing and Informatics (ESCI), Pune, India; 2023. p. 1–5. DOI: 10.1109/ESCI56872.2023.10099544.
4. Kasat K, Shaikh N, Rayabharapu VK, Nayak M, Sayyad Liyakat KK. Implementation and recognition of waste management system with mobility solution in smart cities using Internet of Things. Second International Conference on Augmented Intelligence and Sustainable Systems (ICAISS), Trichy, India; 2023. p. 1661–5. DOI: 10.1109/ICAISS58487.2023.10250690.
5. Kazi K. AI-driven IoT (AIIoT) in healthcare monitoring. In: Nguyen TVT, Vo NTM, editors. Using Traditional Design Methods to Enhance AI-Driven Decision Making. IGI Global; 2024. p. 77–101. Available at: <https://www.igi-global.com/chapter/ai-driven-iot-aiiot-in-healthcare-monitoring/336693>. DOI: 10.4018/979-8-3693-0639-0.ch003.
6. Kazi K. Modelling and simulation of electric vehicle for performance analysis: BEV and HEV electrical vehicle implementation using Simulink for E-mobility ecosystems. In: Kassarwani V, Nagpal N, Kassarwani N, editors. IGI Global; 2024. p. 295–320. Available at: <https://www.igi-global.com/gateway/chapter/full-text-pdf/341172>. DOI: 10.4018/979-8-3693-2611-4.ch014.
7. Veena C, Sridevi M, Liyakat KKS, Saha B, Reddy SR, Shirisha N. HEECCNB: An efficient IoT-cloud architecture for secure patient data transmission and accurate disease prediction in healthcare systems. Seventh International Conference on Image Information Processing (ICIIP), Solan, India; 2023. p. 407–10. DOI: 10.1109/ICIIP61524.2023.10537627.
8. Prasad KR, Karanam SR, Ganesh D, Liyakat KKS, Talasila V, Purushotham P. AI in public-private partnership for IT infrastructure development. *J High Technol Manag Res.* 2024;35:100496. DOI: 10.1016/j.hitech.2024.100496.
9. Nagrale M, Pol RS, Birajadar GB, Mulani AO. Internet of robotic things in cardiac surgery: An innovative approach. *Afr J Biol Sci.* 2024;6:709–25. DOI: 10.33472/AFJBS.6.6.2024.709-725.
10. Kazi KSL. IoT driven by machine learning (MLIoT) for the retail apparel sector. In: Tarnanidis TK, Papachristou E, Karypidis M, Ismyrlis V, editors. Driving Green Marketing in Fashion and Retail. IGI Global; 2024. p. 63–81. DOI: 10.4018/979-8-3693-3049-4.ch004.
11. Kazi KSL. Machine learning (ML)-based Braille Lippi characters and numbers detection and announcement system for blind children in learning. In: Sart G, editor. Social Reflections of Human-Computer Interaction in Education, Management, and Economics. IGI Global; 2024. p. 16–39. DOI: 10.4018/979-8-3693-3033-3.ch002.
12. Kazi KSL. Artificial intelligence (AI)-driven IoT (AIIoT)-based agriculture automation. In: Satapathy S, Muduli K, editors. Advanced Computational Methods for Agri-Business Sustainability. IGI Global; 2024. p. 72–94. DOI: 10.4018/979-8-3693-3583-3.ch005.
13. Kutubuddin K. Vehicle health monitoring system (VHMS) by employing IoT and sensors. *Grenze Int J Eng Technol.* 2024;10:5367–74.
14. Kazi KS. Computer-aided diagnosis in ophthalmology: A technical review of deep learning applications. In: Garcia MB, Almeida RPP, editors. Transformative Approaches to Patient Literacy and Healthcare Innovation. IGI Global; 2024. p. 112–35. Available at: <https://www.igi-global.com/chapter/computer-aided-diagnosis-in-ophthalmology/342823>. DOI: 10.4018/979-8-3693-3661-8.ch006.
15. Magadam PK. Machine learning for predicting wind turbine output power in wind energy conversion systems. *Grenze Int J Eng Technol.* 2024;10:2074–80.
16. Nerkar PM, Dhaware BU. Predictive data analytics framework based on heart healthcare system (HHS) using machine learning. *J Adv Zool.* 2023;44(Special Issue):3673–86.
17. Neeraja P, Kumar RG, Kumar MS, Liyakat KKS, Vani MS. DL-based somnolence detection for improved driver safety and alertness monitoring. IEEE International Conference on Computing, Power and Communication Technologies (IC2PCT), Greater Noida, India; 2024. p. 589–94.
18. Liyakat KKS. Explainable AI in healthcare. In: Kamaraj AA, Acharjya DP, editors. Explainable Artificial Intelligence in Healthcare System. IGI Global; 2024. DOI: 10.52305/GOMR8163.
19. Liyakat KKS. ChatGPT: An automated teacher’s guide to learning. In: Bansal R, Chakir A, Ngah AH, Rabby F, Jain A, editors. AI Algorithms and ChatGPT for Student Engagement in Online Learning. IGI Global; 2024. p. 1–20. DOI: 10.4018/979-8-3693-4268-8.ch001.

20. Kutubuddin K. A novel approach on ML-based palmistry. *Grenze Int J Eng Technol.* 2024;10:5186–93.
21. Kutubuddin K. IoT-based boiler health monitoring for sugar industries. *Grenze Int J Eng Technol.* 2024;10:5178–85.
22. Liyakat KKS. Explainable AI in healthcare. *Explainable Artificial Intelligence in Healthcare Systems.* 2024; p. 271–84.
23. Kazi KSL. Machine learning-based pomegranate disease detection and treatment. In: Zia Ul Haq M, Ali I, editors. *Revolutionizing Pest Management for Sustainable Agriculture.* IGI Global; 2024. p. 469–498. DOI: 10.4018/979-8-3693-3061-6.ch019.
24. Khadake SB, Patil VJ. Prototype design & development of solar-based electric vehicle. *3rd Int Conf Smart Gen Comput Commun Netw (SMART GENCON);* 2023; Bangalore, India. p. 1–7. DOI: 10.1109/SMARTGENCON60755.2023.10442455.
25. Patil VJ, Khadake SB, Tamboli DA, Mallad HM, Takpere SM, Sawant VA. Review of AI in power electronics and drive systems. *3rd Int Conf Power Electron IoT Appl Renew Energy Control (PARC);* 2024; Mathura, India. p. 94–99. DOI: 10.1109/PARC59193.2024.10486488.
26. Khadake SB. Detecting salient objects of natural scenes in a video using spatiotemporal saliency and colour map. *JNX - Multidiscip Peer Rev J.* 2021;2:30–5.
27. Dolli SP, Rathod KS, Waghmare OP, Deshpande AV. An overview of Intelligent Traffic Control System Using Plc and use of current data of vehicle travels. *JNX Multidiscip Peer Rev J.* 2021;1–4. Available at: <https://repo.journalnx.com/index.php/nx/article/view/739>.
28. Patil VJ, Khadake SB, Tamboli DA, Mallad HM, Takpere SM, Sawant VA. A comprehensive analysis of artificial intelligence integration in electrical engineering. *5th Int Conf Mob Comput Sustain Informatics (ICMCSI);* 2024; Lalitpur, Nepal. p. 484–491. DOI: 10.1109/ICMCSI61536.2024.00076.
29. Khadake S, Kawade S, Moholkar S, Pawar M. A review of 6G technologies and its advantages over 5G technology. In: Pawar PM, Ronge BP, Gidde RR, Pawar MM, Misal ND, Budhewar AS, More VV, Reddy PV, editors. *Techno-Societal 2022.* Springer International Publishing; 2024. p. 1043–51. DOI: 10.1007/978-3-031-34644-6\_107.
30. Dudgikar B, Akbar Ingalgi AA, Gensidha Jamadar A, Onkar Rameshchandra Swami, Suhas Balram Khadake, Shreya Vikram Moholkar. Intelligent battery swapping system for electric vehicles with charging stations locator on IoT and cloud platform. *Int J Adv Res Sci Commun Technol.* 2023;3:204–208. DOI: 10.48175/IJARSCT-7867.
31. Padavale P, Dhare M, Bharati M. Automatic Hand Dispenser and Temperature Scanner for Covid-19 Prevention. *Int J Adv Res Sci Commun Technol.* 2023;3:362–367. DOI: 10.48175/IJARSCT-11364.
32. Suhas B. Detecting salient objects in A video's by using spatio-temporal saliency & colour map. *Int J Innov Eng Res Technol.* 2021;3:1–9.
33. Kashid PJ, Kawade AM, Khedekar SV, Mallad HM. Electric Vehicle Technology Battery Management -Review. *Int J Adv Res Sci Commun Technol.* 2023;3:319–325. DOI: 10.48175/IJARSCT-13048.
34. Wale Anjali D, Dipali R, et al. Smart agriculture system using IoT. *Int J Innov Res Technol.* 2019;5:493–497.
35. Kazi K. Model for agricultural information system to improve crop yield using IoT. *J Open Source Dev.* 2022;9:16–24.
36. Liyakat KKS. Intelligent Watering System (IWS) for agricultural land utilising Raspberry Pi. *Recent Trends Fluid Mech.* 2024;10:26–31.
37. Sunil Shivaji Dhanwe et al. AI-driven IoT in robotics: A review. *J Mech Robot.* 2024;9:41–48.
38. Liyakat KSS, Liyakat KKS. Nanomedicine as a potential therapeutic approach to COVID-19. *Int J Appl Nanotechnol.* 2023;9:27–35.
39. Liyakat KKS. *Intelligent Watering Systems.* 2024.
40. Liyakat S. Intelligent Watering System (IWS) for agricultural land utilising Raspberry Pi. *Recent Trends Fluid Mech.* 2023;10:26–31.

41. Liyakat KKS. IoT and sensor-based smart Agriculturing driven by NodeMCU. *Res Rev Electron Commun Eng.* 2024;1:25–33.
42. Liyakat KKS. Smart agriculture based on AI-driven-IoT (AIIoT): A KSK approach. *Adv Res Commun Eng Innov.* 2024;1:23–32.
43. Kazi KK. Complications with malware identification in IoT and an overview of artificial immune approaches. *Res Rev J Immunol.* 2024;14:54–62.
44. Khadake SB, Chounde A, Gopnarayan BB, Patil KB, Kamble SS. Human health care system: A new approach towards life. *Grenze Int J Eng Technol.* 2024;10:5487–5494.
45. Khadake SB, Patil VJ, Mallad HM, Gopnarayan BB, Patil KB. Maximize farming productivity through Agriculture 4.0-based intelligence, with use of Agri-tech sense advanced crop monitoring system. *Grenze Int J Eng Technol.* 2024;10:5127–5134.