

Three Techniques for DC Thevenin Resistance Using Pspice Simulation

K. Bharath Kumar^{1,*}

Abstract

A time-domain method for certain types of excitations is proposed to determine Thevenin equivalent circuit for a circuit with resistors and dependent/independent sources. SPICE/PSpice model descriptions for resistors at constant temperature and dependent source are used. Instead of making the energy sources zero (as in frequency domain) the sources in time domain are described using model description cards available for time-domain current/voltage sources at the same time evaluating circuit for the waveforms described using built-in model cards. Further, the energy sources can be circulated, that is, replace one with the other and obtain same Thevenin resistance. Also, different values for current/voltage can be given. The presented technique can be applied to networks with (a) resistor in series with parallel combination of three (or many) resistors and (b) resistors in series with a parallel combination of a resistor, resistor parallel resistors, using analog behavior options available in PSpice software. Time-domain sources such as pulse and piecewise linear (PWL) (both current/voltage) are used. Examples to obtain Thevenin resistance for a circuit is given and verified with SPICE transfer function (TF command) to calculate DC output resistance. A theoretical network is considered as an example to implement a Thevenin resistance of another independent network in the time domain, in the required chosen time. This circuit with Thevenin resistance is simulated and the results are verified. This approach introduces three distinct techniques for obtaining DC Thevenin parameters: (i) combining two different networks with two known circuits to derive Thevenin parameters, (ii) varying individual Thevenin resistance according to voltage-current (V/I) variations in PSpice, and (iii) adding or subtracting resistance to modify the Thevenin DC resistance for use in circuit simulation.

Keywords: Thevenin equivalent circuit, time-domain analysis, SPICE/PSpice, simulation, resistor networks, dependent and independent sources

INTRODUCTION

In recent/coming years, a rich collection of circuit and network simulators would be available, which are/can be used individually or simultaneously for circuit (linear and non-linear) drawing, circuit design and analysis or both as well. It consists of well-structured free circuit simulation software (programs), open-source circuit analysis and simulation (design) software, simple (complicated) and easy to use simulators, nonlinear simulator, windows-based radio-frequency (RF)/microwave simulator (with graphic display), etc. After researching through all the available list, the following are a collection of best circuit simulation software.

*Author for Correspondence

K. Bharath Kumar
E-mail: bbkrishnapuram3@yahoo.com

¹Formerly Researcher, Oki Electric Company, R&D Division, Tokyo, Japan

Received Date: December 27, 2024
Accepted Date: January 05, 2025
Published Date: February 08, 2025

Citation: K. Bharath Kumar. Three Techniques for DC Thevenin Resistance Using Pspice Simulation. Journal of Semiconductor Devices and Circuits. 2025; 12(1): 1–8p.

GNU CAP: A generally accepted and special purpose circuit simulator (GNU General Public License Circuit analysis package), this Linux-based circuit simulator is used in conjunction with many circuits analysis and optimization of functions such as DC and transient analysis, AC analysis etc. (have incorporated Piece/spice compatible model for metal oxide semiconductor field effect transistor [MOSFET], bipolar junction transistor [BJT] (bipolar) and junction diode).

NgSpice: It is a different and very useful (popular and widely used) free, open-source circuit circuit/package which can be obtained from Source forge. Users collectively developed NgSpice and its code originated on three open-source software programs: known as (a) Spice3f5, (b) Cider and (c) Xspice. Suggestions and improvements are considered in this collaborative work for improvement.

Micro-Cap 10: A demo version of this circuit analyzer and simulator is available from Spectrum Soft. It has a friendly user compatible interface with a mixed mode digital/analog circuit simulator, and a fast simulation and accurate reliable performance.

PECS: A free, useful for power electronics engineers, a circuit simulator created and can be download with various printed manuals and tutorial examples. You can download the various manuals and tutorials from the website before starting using the simulation tool A website is available and it can be used for verification purposes.

Proteus: Prospice is a mixed mode simulator from LaCenter, and it is a Spice-based simulation package. It consists of two different versions (a) basic, (b) advanced: basic version is freely available and supports interactive simulation. Advanced version supports various features (and graph-based analyses) including frequency, noise, distortion, and Fourier parameters.

QUCS: A software which can be used on operating systems such as Solaris, Apple Macintosh, Microsoft windows, FreeBSD, NetBSD platforms – small signal and large signal universal circuit simulator available freely.

EasyEDA: Free software available for electronic designers.

LTSpice: Another widely used, popular, free SPICE simulator from Linear Technology. Compared to normal SPICE simulator variants, it has an advantage of carrying fast simulation of switching regulators. LTspice gives access to more than 200 op amp models, transistor models (BJT), diode, FET, Hemet, mesfet, MOSFET models, etc.

CircuitLogix: Available for students in electronics, electrical, electromagnetics as a free software, from Circuit Logix. More than three thousand devices are incorporated(provided) for SPICE/PSpice simulation users -in the professional version (access to electronic switches, linear integrated circuit (IC) and digital IC, FET, transistors, electronic relays, displays, analog signal generators, silicon-controlled rectifiers (SCRs), thyristors, opto isolators, photo diodes, semiconductors, AC and DC motors, etc.).

MultiSim: A simulation software from National Instruments for electronic/electrical design engineers, academic individuals and educators, colleges, students, institutions, and professionals. Although the student version comes with limited access for beginners this is still widely used. The following operations can be performed: the circuit maker software enables you to capture/manage circuits, create layouts, analyze circuits (networks) and simulation, including exploring breadboard in 3D/2D before lab assignment submission, creating bread board calculation, printed circuit boards (PCBs) availability.

TopSpice: Both Pspice and Hspice compatible simulation of circuits can be obtained. A demo version circuit simulator from Penzar. This electronic simulation tool is tailored to work with Windows only and it is compatible with Windows XP/Vista/7. TopSpice is a mixed mode, digital signal, analog signal, behavioral simulation/modeling software.

Circuit Simulator 1.5: This is a freeware circuit simulation tool. It is just a basic circuit tool with very basic functions, created for starters'/students' purpose.

Micro-Cap 10: A demo version circuit analyzer and simulator from Spectrum Soft. And is claimed as a mixed mode digital/analog circuit simulator with an intuitive user interface, fast simulation and great performance can be achieved.

Proteus: Two versions of Prospice are a mixed mode (basic and advanced) simulation tool from Lab Center. Basic version is free, which supports interactive simulation only while advanced supports a range of useful functions options and features like graph-based analysis which includes frequency, noise, distortion, Fourier parameters, etc.

QUCS: In GNU/Linux environment (Quite Universal Circuit Simulator) is a free simulation software. This software works on other operating systems such as Solaris, Apple Macintosh, Microsoft windows, FreeBSD, NetBSD etc. User can simulate large signal, small signal and noise behavior of the circuit using this simple circuit simulator.

MacSpice: It can perform simulation ranging from a single resistor to an integrated circuit with thousands of devices and components packed together and a free circuit simulation software for Apple Macintosh users. This network (circuit simulation), derived from Berkeley Spice, is compatible with PowerPC and Intel architecture Apple Macintosh (Mac PC).

SimScale: A cloud-based simulation software for interested internet users.

Solve Elec: User friendly software enabling to draw and analyze circuits in electrical and electronic representation: free version, which is developed for Macintosh OS and Windows (functioning in direct current or alternating current, get formulas, verify equations, get equivalent circuits etc.).

Several circuit modeling software available for users in the market are:

PSPICE Orcad: This can be used in conjunction with SPICE text books. Once the student develops interest in Mixed signal, it is an industry standard circuit simulator and is used by many professionals, engineers for electronic circuit/network system design and development (developed by the same company, Cadence).

SiMetrix: In addition to products like Simples, Micron VX, DVM, etc., it is a circuit simulation tool with enhanced Spice specifically developed for professional electronic design engineers.

TINA: Powerful tool in mathematical functions. Circuit simulation can be obtained – cost-effective and also with circuit design. A basic version of TINA design suite (versions) for low and medium prices is for buyers.

PowerSim: Several simulation tools for power electronics are available. This simulation tool (simulation software) is developed for high voltage power electronics circuits, motor/generator control and other requirements such as dynamic system simulation.

Thevenin's theorem [1–3] can be used in requirements such as to determine the current through or voltage across any one circuit element/component without the need for the usual complex method of solving a set of network equations, using matrices and other algebraic methods.

THEVENIN'S THEOREM

A DC network (two terminal bilateral linear DC circuit) can be /represented by an equivalent circuit/network consisting of voltage energy source in series with a resistance, the energy source being the open circuited voltage across the open circuited load terminals and the resistance being the input resistance directly looking into the disconnected (with all energy sources made zero) circuit for which the Thevenin equivalent is desired.

THEORY: CIRCUIT EQUIVALENT

- *Step 1:* First, remove the load resistor (R_L) and find the open circuited voltage ($V_{OC} = V_{Th}$) across the open circuited load terminals using Kirchhoff's Voltage Law(KVL)/ Kirchhoff's Current Law (KCL).
- *Step 2:* Constant ideal and non-ideal sources (for voltage source, remove it by internal resistance/short and for current source replace the source by open circuit/source admittance) and find the back resistance (R_{Th}) looking through the open circuited disconnected load terminals.
- *Step 3:* The circuit can be seen as a (Thevenin's) equivalent circuit by placing R_{Th} in series with V_{Th} . The load resistor (R_L) across the load terminals is again connected, and the required current through (voltage across) the load is determined.

Finding Thevenin's Equivalent Resistance (R_{Th})

The following procedure is used for networks with independent sources, dependent sources, or both

- By deactivating(substituting) the sources by their internal resistance (for independent ideal voltage source, deactivate it by shorting it and for independent ideal current source, deactivate it by removing the source).
- The open circuit voltage V_{ith} across the open circuited load terminals is determined. Next, the load terminals are shorted and the short circuit current (I_{sc}) through the shorted terminals is determined. The Thevenin's equivalent resistance is given by,

$$R_{Th} = V_{th}I_{sc}$$
- Initially the load resistance has to be removed, and a DC test voltage (V_T) is applied at the open circuited load terminals. The internal resistance can be obtained from the direct current (I_{Tk}) (measurement) flowing in the circuit from the load terminals due to application of V_{Tk} . The internal resistance or Thevenin's equivalent resistance of the source network is obtained as,

$$R_{Th} = V_{Tk}I_{Tk}$$

Thevenin and Norton equivalent circuits of networks obtained by different methods are used in circuit simulation and modeling by designers and researchers. In the above references, different methods to obtain the Thevenin resistance (impedance) and Norton conductance (impedance) of a network with available substitution network theorem, the SPICE circuit simulation software has been used, different Thevenin impedances are implemented for desired networks from other networks. the Thevenin parameters are also calculated for impedances described by Laplace transform. Instead of DC option, the transient analyses option of SPICE/PSpice is used to determine Thevenin/Norton conductance/resistance to pure resistive and active circuits, using pulse, piece-wise sources for voltage to current. The method can be extended (compatible)to personal computer software like OrCAD, MicroCAP, also can be applied to active circuits represented by their small signal models at DC. The results are also verified by verified by Spice/PSpice (TF) option available.

SIMULATION TECHNIQUE TO OBTAIN THEVENIN/NORTON RESISTANCE

In the present work, the Thevenin resistance is obtained either by PROBE graphic or by PSpice Netlist run printout. Three types of sources are used in the transient analyses (with partial time scale used in time-domain). It is different from previous works:

- In reference [4], different Thevenin impedances from other circuits are transferred by a technique in the frequency domain using Spice program.
- In reference [5], DC option is used to obtain Thevenin resistance with polynomial sources.
- In reference [6], SPICE program is used to obtain two algebraic equations with solution in frequency domain to obtain Thevenin impedance.
- In the work described in reference [7], Thevenin impedance for coupled network for a non-linear device is obtained. The coupled network impedances are described by Laplace option of analog behavioral modeling of PSpice.

- In reference [8], the Thevenin resistance is obtained by dividing voltage by current using variant of substitution theorem of network theory. The PSpice/Spice transient analyses with polynomial sources are used for this purpose.

The network represented by Thevenin open circuit voltage (E_c) and Thevenin resistance (R_T) is connected to a load (R_L) as shown in Figure 1a. If Thevenin open circuit voltage ($E_c = 0$ V) then if the network is terminated by a current source of value (-1 A), the voltage across it gives Thevenin resistance (R_T), as shown in Figure 1b [9, 10].

The Norton equivalent circuit for a linear network(active/passive) with an arbitrary load, is shown in Figure 1c for the same network described before, whose Norton conductance (G_{NOR}) is to be determined between terminals C and D. If the short circuit current is made zero ($I_{sc} = 0$ A), then the current through 1V DC source (I_{kk}) gives Norton conductance (Figure 1d).

PRESENT SIMULATION USING TIME DOMAIN TO DETERMINE THEVENIN RESISTANCE

Energy sources in time domain (built-in models) like piece-wise linear, pulse is connected in a network with resistors and dependent energy sources (described in time domain) for which the Thevenin resistance is to be determined. These sources are switched ON/OFF by describing the model parameters in the desired time-interval where Thevenin resistance is required, and which is also DC Thevenin resistance. Figure 2a shows a network with voltage/current independent pulse, piece-wise linear time domain sources. The Thevenin resistance (across R, S terminals) of this circuit is 25 ohm as calculated by (TF) command of SPICE program as described by Table 1.

Figure 2b shows a different circuit where the Thevenin resistance 25 ohm should be incorporated. According to Figure 1b and 1d, when Thevenin voltage is zero the Thevenin resistance is the input impedance across R, S terminals. Tables 2 and 3 show the implementation results of Thevenin resistance using this principle in time domain with Spice/PSpice program.

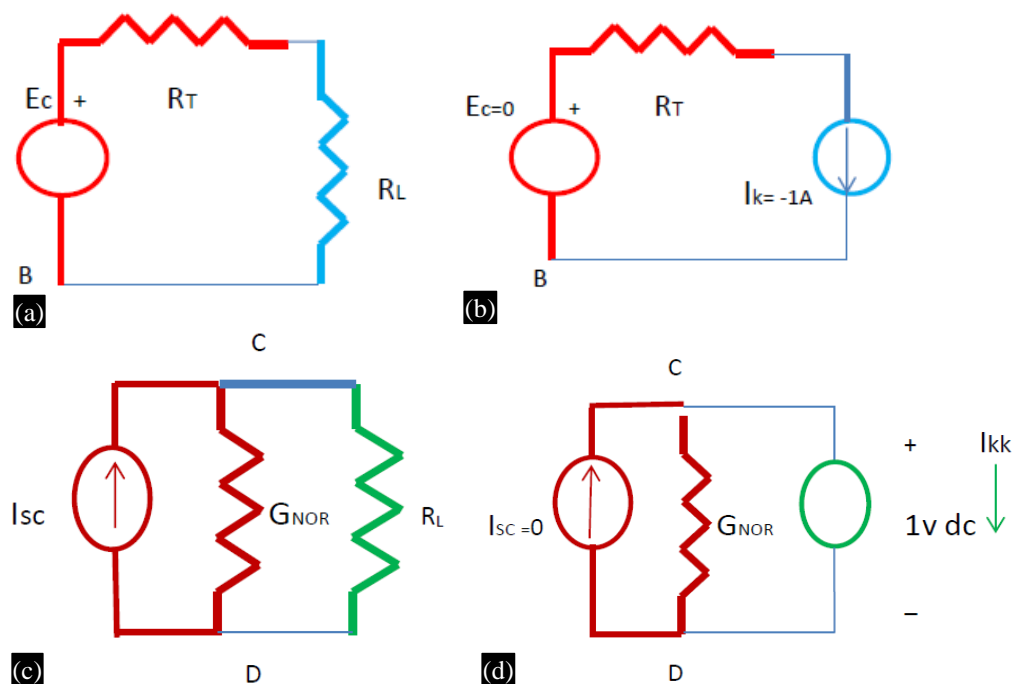

Figure 1. (a, b) Thevenin equivalent circuit with load R_L and Thevenin resistance measurement using a current source. (c, d) Norton equivalent circuit with load R_L and Norton conductance determination using a 1 V DC source.

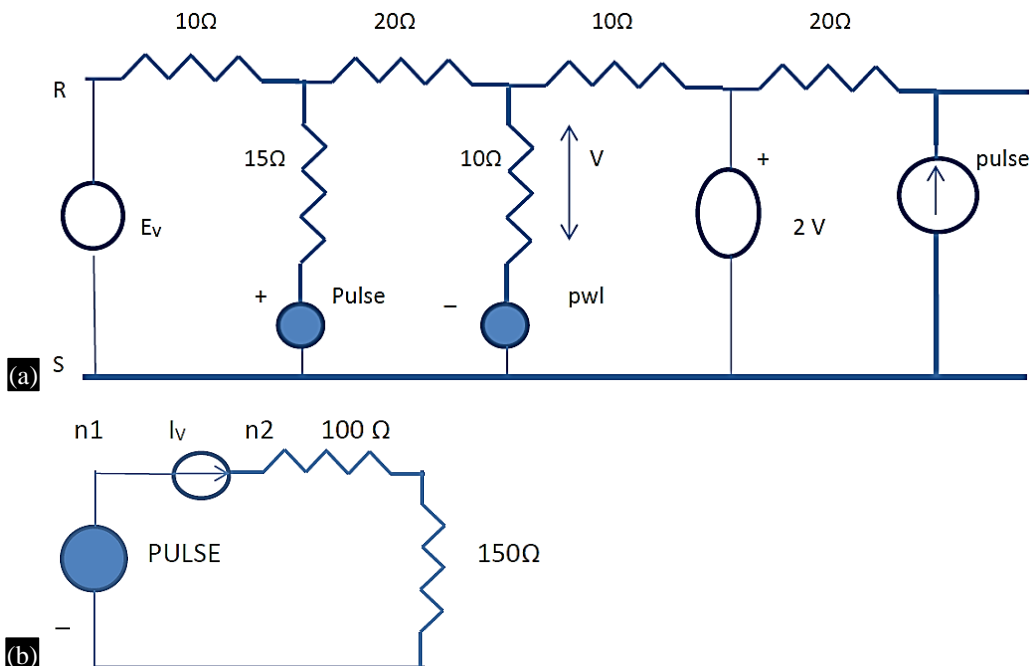

Figure 2. (a) Network whose Thevenin resistance (across R and S) is incorporated in Figure 2b. (b) A circuit where Thevenin resistance is between nodes (n1 and n2).

Table 1. Spice file to determine DC Thevenin resistance with TF command.

**** 11/27/24 13:09:12 ***** PSpice Lite (October 2012) ***** ID# 10813 ****
DC Thevenin Resistance Verified (TF) Command
**** Circuit Description

r12 1 2 10
r26 2 0 15
r23 2 3 20
r37 3 0 10
r45 4 5 20
R50 5 0 1E18
r34 3 4 10
e40 4 0 3 0 2
I01 0 1 DC 1
.TF V(1) I01
.op
.PROBE
.end
**** 11/27/24 13:09:12 ***** PSpice Lite (October 2012) ***** ID# 10813 ***
DC Thevenin Resistance Verified (Tf) Command
**** Small Signal Bias Solution Temperature = 27.000 DEG C

Node Voltage Node Voltage Node Voltage Node Voltage
(1) 25.0000 (2) 15.0000 (3) 15.0000 (4) 30.0000
(5) 30.0000
Voltage source currents

Name Current
Total Power Dissipation 0.00E+00 WATTS
**** 11/27/24 13:09:12 ***** PSpice Lite (October 2012) ***** ID# 10813 ****
DC Thevenin Resistance Verified (TF) Command
**** Operating Point Information Temperature = 27.000 DEG C

**** Voltage-Controlled Voltage Sources
Name e40
V-Source 3.000E+01
I-Source -1.500E+00
**** Small-Signal Characteristics
V(1)/I01 = 2.500E+01
Input Resistance At I01 = 2.500E+01
Output Resistance At V(1) = 2.500E+01
Job Concluded

Table 2. Spice file for Figure 2a and b implementing Thevenin resistance.

**** 11/27/24 12:49:52 ***** PSpice Lite (October 2012) ***** ID# 10813 ***
File for figure 2, thevenin resistance is across nodes (1)&(2)
**** Circuit Description

r12 1 2 10
r26 2 6 15
v60 6 0 pulse(0 1v 0 0 0 20us 40us)
r23 2 3 20
r37 3 7 10
r45 4 5 20
R50 5 0 1E18
v 0 7 pwl(0 0 10us 2 20us 0 40us 0 50us 2 60us 0)
r34 3 4 10
e40 4 0 3 7 2
i05 0 5 pulse(0 2 0 0 0 20us 40us)
Ei01 11 0 8 9 1
VIN 11 1
*Circuit With Thevenin Resistance Of Figure 2
VE 8 0 PULSE(0 2 0 0 0 40US 80US)
F89 8 9 VIN 1
R910 9 10 100
R100 10 0 150
.TRAN 5US 50US 10US
.PRINT TRAN V(10) V(9)
.op
*.PROBE
.end

The results obtained by running the code in Table 2 are given in Table 3. The Thevenin resistance 25 ohm (Figure 2a) is connected in the time period (20–40 μ s) across n1 and n2 in Figure 2b.

Table 3. Spice results for Figure 2b in time domain.

Time	V(10)	V(9)
1.000E-05	-1.091E+00	-1.818E+00
1.500E-05	-2.727E-01	-4.545E-01
2.000E-05	5.455E-01	9.091E-01
2.500E-05	5.455E-01	9.091E-01
3.000E-05	1.091E+00	1.818E+00
3.500E-05	1.091E+00	1.818E+00
4.000E-05	1.091E+00	1.818E+00
4.500E-05	-2.727E-01	-4.545E-01
5.000E-05	-2.182E+00	-3.636E+00

CONCLUSIONS

After running the SPICE/PSpice netlist file the Thevenin resistance is:

The Thevenin resistance is the input voltage as the energy sources are switched OFF in 20–40 μ s. It is true for piecewise linear and pulse sources. A common method is using TF analyses in DC option of SPICE computer program to determine Thevenin/Norton resistance. Also, how a different circuit into which Thevenin resistance from another circuit is to be incorporated is described in the required time scale. A different circuit where this Thevenin resistance is implemented in time-domain is also described with results. These results are also verified by connecting DC Thevenin resistance in that time scale (period).

The transient option of SPICE program can also be used to obtain Thevenin/Norton resistance/conductance for resistive circuits with both independent active sources replaced by small signal circuits and can be verified with other simulation software having only transient analyses computation facility. The results can be obtained as a graphical display (PROBE) for visual observation. A computer program to verify the above results using FORTRAN can also be written and extended to different networks/ circuits.

REFERENCES

1. Van Valkenburg ME. Network Analysis. 3rd edition. New York, Ny, USA: Prentice-Hall; 1976. Chapter IX, pp. 259–261.
2. Thomas RE, Rosa AJ, Toussaint GJ. The Analysis and Design of Linear Circuits. 8th edition. Hoboken, NJ, USA: John Wiley & Sons; 2015.
3. Nahvi M, Joseph A. Administer, Electric Circuits, Schaum's Outline Series. 4th edition. New York, NY, USA: McGraw Hill; 2003. Chapter IV, pp. 44–45.
4. Bharath Kumar K. Methods to obtain a new circuit whose Thevenin and Norton equivalents are functions of two different Thevenin and Norton circuit. *Electro Bits*. 2023; May: 37–44.
5. Bharath Kumar K. Using substitution theorem to derive Thevenin resistance values with SPICE. *EDN-Magazine*. September 10, 2021.
6. Bharath Kumar K. SPICE to derive Thevenin and Norton equivalent circuits. *EDN Magazine Online Edition*, February 14, 2022.
7. Bharath Kumar K. T- π network simulation and Thevenin-Norton equivalent circuit values from Laplace description using Pspice software. *J Semiconductor Devices Circuits*. 2022; 9 (2): 43–58.
8. Bharath Kumar K. Thevenin and Norton resistance using time domain analyses using SPICE simulations. *Curr Trends Signal Process*. 2023; 13 (2): 8–18.
9. Yang WY, Kim J, Park KW, Baek D, Lim S, Joung J, Park S, Lee HL, Choi WJ, Im T. *Electronic Circuits with MATLAB, PSpice, and Smith Chart*. Hoboken, NJ, USA: John Wiley & Sons; 2020.
10. Sun X, Lee YS, Xu D. Modeling, analysis, and implementation of parallel multi-inverter systems with instantaneous average-current-sharing scheme. *IEEE Trans Power Electron*. 2003; 18 (3): 844–856.