

## Low-cost Vehicle Data Acquisition System

Darshan Jogi<sup>1</sup>\*, K.P. Joshi<sup>2</sup>, Harsh Wankhade<sup>3</sup>, Aditya Tanpure<sup>4</sup>

### Abstract

*The Vehicle and Driver Data Acquisition System Kit is an integrated solution designed to capture, analyze, and store essential information related to both vehicles and their drivers. This comprehensive kit incorporates cutting-edge sensors, communication modules, and data processing capabilities to provide a robust platform for real-time monitoring and post-event analysis. In the domain of electric vehicles (EVs), the need for effective data collection systems has become increasingly crucial. The current technologies are encountering difficulties in terms of data precision, integration, and live monitoring. This kit presents a fresh solution that utilizes the ESP32, DHT11 sensor, ESP32-CAM module, and a driver heart rate sensor. Our innovation tackles these challenges by offering a comprehensive and integrated data collection system that improves data precision and enables real-time monitoring, thus ensuring safer and more efficient EV operations. The kit aims to provide a feasible and user-friendly solution, addressing the challenges associated with traditional data acquisition methods. The Vehicle and Driver Data Acquisition System Kit incorporates advanced sensors and communication modules to gather comprehensive data related to vehicle dynamics, engine performance, and driver behavior. The feasibility of the system is underscored by its adaptability to various vehicle models, making it a versatile solution for both personal and commercial applications.*

**Keywords:** Data acquisition, kit, Electric vehicle, ESP32, DHT11 sensor, ESP232-CAM module

### INTRODUCTION

**Background:** The automotive industry is witnessing a transformative phase with the integration of smart technologies to enhance the performance, safety, and efficiency of electric vehicles. Traditional vehicles have been equipped with various sensors and data acquisition systems, but the unique challenges and requirements of electric vehicles demand tailored solutions. The integration of ESP32 and ESP8266 microcontrollers, along with the DHT11, ESP cam module, and MAX 30100 sensor, offers a versatile platform for comprehensive data gathering. The "Low-Cost Vehicle Data Acquisition System" offers a cutting-edge method for utilizing reasonably priced technology to collect and analyze vital vehicle performance data. The goal of this system is to make full vehicle diagnostics and performance monitoring more widely available. Previously, these services were only available through pricey proprietary systems. The system allows for real-time monitoring and analysis of important metrics including engine performance, fuel efficiency, and vehicle dynamics by utilizing affordable

components and open-source software. This article examines the low-cost vehicle data acquisition system's design, implementation, and possible uses, emphasizing how it can improve fleet management operations, improve vehicle maintenance procedures, and support research in automotive engineering and transportation technology. This system is a desirable option for researchers, small businesses, and car enthusiasts who want to use data-driven insights to boost vehicle efficiency and performance because of its accessibility and affordability [4–7].

#### \*Author for Correspondence

Darshan Jogi  
E-mail: darshanjogi22@gmail.com

<sup>1-4</sup>Student, Department of Electronics & Telecommunication Engineering, Smt Kashibai Navale College of Engineering, Pune, Maharashtra, India

Received Date: July 12, 2024  
Accepted Date: July 22, 2024  
Published Date: August 14, 2024

**Citation:** Darshan Jogi, K.P. Joshi, Harsh Wankhade, Aditya Tanpure. Low-cost Vehicle Data Acquisition System. Journal of Microwave Engineering & Technologies.2024;11(2):9–14p.

---

The Vehicle and Driver Data gathering System Kit addresses the drawbacks of traditional data gathering methods by providing a workable and intuitive solution. The package facilitates comprehensive data collection on vehicle dynamics, engine performance, and driver behavior by integrating modern sensors and communication components. Because of its adaptability to various car models, it may be used for both personal and business purposes with ease. This technology claims to increase operational savings across a variety of applications and expedite vehicle monitoring in addition to improving data accessibility and accuracy [7–10].

*Relevance:* The relevance of this research lies in addressing the current gaps in data acquisition systems for electric vehicles. Existing solutions often focus on specific aspects, such as battery management or GPS tracking, but lack an integrated approach that considers both vehicle and driver parameters. Our proposed system aims to bridge this gap by providing a unified and efficient solution, contributing to the advancement of electric vehicle technology.

*Motivation:* The motivation behind this project stems from the need for a holistic understanding of electric vehicle performance and driver behavior. By creating a compact and versatile data acquisition kit, we aim to empower researchers, engineers, and manufacturers with a tool that can facilitate data-driven decision-making, optimize vehicle design, and enhance the overall electric vehicle experience. Electric vehicle safety extends beyond the mechanical components to include the behavior of the driver. Integrating the MAX 30100 sensor allows for real-time monitoring of the driver's health parameters, such as heart rate and oxygen levels. This unique feature adds an additional layer of safety by enabling early detection of driver fatigue or stress, ultimately contributing to safer and more efficient electric vehicle operation. This kit acts as a tool that empowers stakeholders with comprehensive insights, aiding in the optimization of electric vehicle design, performance, and user experience.

*Summary:* The development of the Vehicle and Driver Data Acquisition Kit System for electric vehicles is driven by a profound motivation to address the evolving needs and challenges within the electric mobility landscape. Unlike traditional data acquisition systems that often focus on specific facets of electric vehicles, such as battery performance, our system aims to offer a comprehensive solution that provides a holistic view of the entire electric vehicle ecosystem. By simultaneously capturing data on various parameters, the goal is to unravel the intricate interactions between components, optimizing overall performance and efficiency. Additionally, by developing an open and adaptable platform, we aim to encourage innovation and collaboration within the electric vehicle community. This collaborative approach is crucial for accelerating advancements in electric vehicle technology and collectively addressing emerging challenges.

## LITERATURE SURVEY

### Study of Research Paper 1

#### *Survey 1*

[1] Boddapati Venkata sai Padmaja, Venkata Ratnam Kolluru, and Syam Sai Kota [1] created an IoT-based vehicle monitoring and tracking system utilizing a Node MCU. This paper describes the implementation of vehicle monitoring and tracking systems that use the Blynk platform as a data transfer and visualization medium. The system is designed to detect a variety of vehicle and driver assistance metrics, including engine temperature, distance between vehicles, and tracking of the vehicle's current location.

#### *Survey 2*

[2] Alejandro Gonzalez, Jose Luis Olazagoitia, and Jordi Vinolas [3] present A Low-Cost Data Acquisition System for Automobile Dynamics Applications: The aim of this project is to design, develop, manufacture, and verify a low-cost Arduino-based data acquisition platform that can be used for <80 Hz data acquisition in vehicle dynamics using inexpensive accelerometers. This project addresses the need for the implementation of low-cost acquisition technology in the field of vehicle engineering. Additionally, a comparison between expensive systems and professional vibration

acquisition technologies is conducted, yielding optimal results with an error of 2.19% on road testing for low- and medium-frequency activities.

### Survey 3

[3] In their study, Agus Ulinuha and Ibnu S. Khak [2] developed an embedded instrumentation system for a BLDC-powered electric vehicle, focusing on data acquisition using Arduino and Raspberry Pi. This system monitors and processes various performance metrics in real-time, including speed, power, motor temperature, distance traveled, and estimated remaining distance based on battery capacity. The collected data is presented both graphically and numerically on the vehicle dashboard, facilitating efficient vehicle management. The system underwent testing in both laboratory and real-world conditions, demonstrating high accuracy with average deviations of 0.25 Volt, 0.03 Amp, and 0.43 Watt for voltage, current, and power measurements compared to standard meters. This instrumentation setup proves crucial for enhancing system efficiency and ensuring reliable performance monitoring in BLDC-powered electric vehicles.

## PROPOSED SYSTEM

### Flow of Proposed System

The primary goal of the suggested system (Figure 1) is to preserve the product's novelty by assisting the user in tracking vehicle performance and keeping an eye on driver conduct. Customers can utilize the system to follow a product's history from the beginning to the present usage of the vehicle. This product system is based on IoT, and embedded system is composed of three roles, data extraction, visualization and the safety. In this project customer enters the application. After launching the app, he/she receives vehicle details and various options to investigate. The home screen shows only basic vehicle information with buttons to access other parameters. To access other parameters consumer will have to toggle between different screens using buttons. Consumer will have access to location, temperature and driver heart beats for monitoring the vehicular as well as driver behavior for various track/road conditions. The system design of the proposed system is shown in Figure 2. Each block represents a key component of the system, detailed as follows:

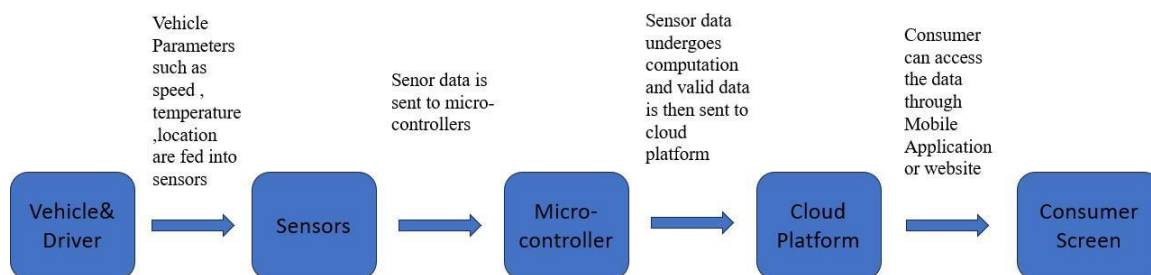
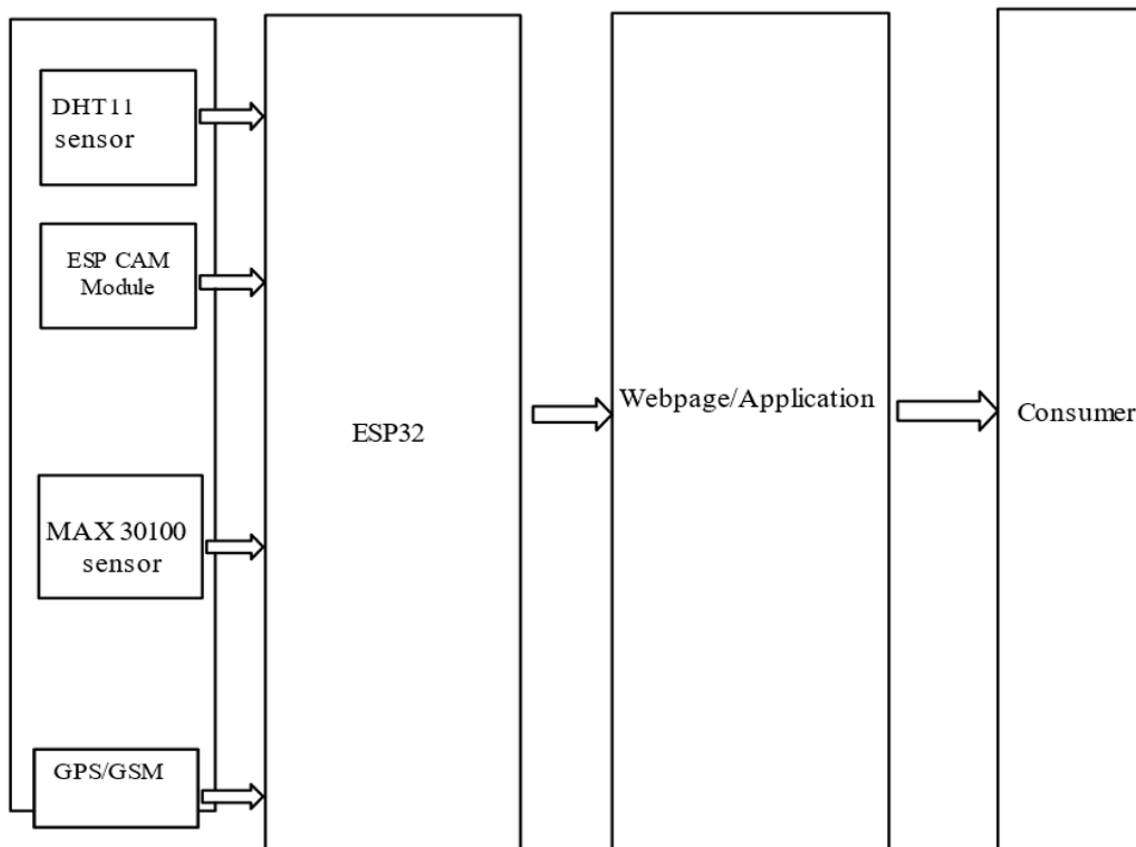

**Figure 1.** Vehicle and driver data acquisition.

1. DHT11 sensor
2. ESP CAM Module
3. MAX 30100 Sensor
4. GPS/GSM
5. ESP32
6. Webpage/Application
7. Consumer

In the "Low-Cost Vehicle Data Acquisition System," a holistic approach integrates multiple components to enhance vehicle monitoring and management. The DHT11 sensor monitors cabin temperature and humidity, ensuring passenger comfort and optimal electronics operation. The ESP CAM Module captures real-time visual data inside and outside the vehicle, crucial for security monitoring, driver behavior analysis, and accident detection. The MAX30100 Sensor tracks the driver's heart rate and blood oxygen levels, providing biometric insights into health status for enhanced safety.

GPS/GSM modules enable real-time vehicle tracking and remote monitoring, leveraging GPS for location data and GSM for status alerts and theft prevention. The ESP32 acts as the central processor, aggregating data from sensors and interfacing with the vehicle's OBD system if available, facilitating cloud or local server data transmission and analysis. A user-friendly Webpage/Application interface empowers vehicle owners and fleet managers to monitor comprehensive data in real-time, including temperature, humidity, visual feeds, driver biometrics, and GPS location, enabling proactive maintenance, improved safety measures, and operational cost reduction.



**Figure 2.** Design Flow of proposed system.

### Vehicle Parameters

Vehicle parameters are the parameters that need to be monitored to study and optimize vehicle performance. These parameters include Motor temperature, Speed, Location and driver data which includes driver heartrate. These parameters play a crucial role in vehicle performance and provides as overview how a vehicle operates at different conditions. The kit can be made accessible to any kind of vehicle, showcasing its flexibility in operating in various vehicles.

### Micro-controller

Micro-controller, specifically in this case ESP32 collects all sensory data and performs various computation to get useful information through them. This micro-controller also sends useful information to cloud platforms enabling wireless transmission of data. Along with their multi-functionality, these micro-controllers are energy efficient and require low power.

### Webpage/Application

Customers can get access to data through webpage or application. They can extract the data in the form of csv files or even just monitor the visualized data available on webpage. This webpage is easily accessible on google or mobile application, which is included in kit installation.

## Result

The implementation of the proposed Vehicle and Driver Data Acquisition Kit has yielded promising results, demonstrating its efficacy in capturing and analyzing critical data for electric vehicles. The integrated system, powered by ESP32 and ESP8266 microcontrollers, successfully monitored environmental conditions through the DHT11 sensor, captured visual data using the ESP Cam module, and monitored driver health parameters with the MAX 30100 sensor. The blockchain integration ensured the immutability and security of the acquired data. Real-time transmission and storage of data facilitated instantaneous access, contributing to informed decision-making processes. The analytics dashboard and user-friendly design provide a simple way to visualize and analyze the data that was gathered. Overall, the results showcase the kit's potential to enhance the safety, efficiency, and overall performance of electric vehicles while providing valuable insights for researchers, engineers, and manufacturers in the electric mobility sector.

## CONCLUSIONS

In conclusion, the development and implementation of the Vehicle and Driver Data Acquisition Kit for electric vehicles have proven to be a significant stride towards comprehensive and insightful data monitoring. The integration of ESP32, ESP8266, DHT11, ESP Cam module, and MAX 30100 sensor successfully addressed the intricate requirements of both vehicle and driver data acquisition. Real-time transmission, storage, and user-friendly interface contribute to practical usability. This kit not only advances the field of electric vehicles by optimizing performance and safety but also stands as a testament to the potential of integrated systems in fostering sustainable and intelligent transportation solutions.

## Acknowledgment

It gives us great pleasure in presenting the preliminary project report on '*Vehicle and Driver Data Acquisition System Kit*'. I would like to take this opportunity to thank my internal guide *Mrs. Kanchan Joshi* for giving me all the help and guidance I needed. I am really grateful to them for their kind support. Their valuable suggestions were very helpful. I am also grateful to HOD *Dr. S. K. Jagtap*, Head of the Electronics and Telecommunications Engineering Department, SKNCOE for her indispensable support, suggestions. We are also thankful to our Principal *Prof. Dr. A. V. Deshpande*, who provided his constant support and motivation that made a significant contribution to the success of this project.

## REFERENCES

1. Boddapati Venkata sai Padmaja, Venkata Ratnam Kolluru, Syam Sai Kota, " IoT based Implementation of Vehicle Monitoring and Tracking system using Node MCU", International Journal of Innovative Technology and Exploring Engineering (IJITEE) ISSN: 2278–3075, Volume-8 Issue-6, April 2019.
2. Ulinuha A, Khak IS. Embedded Instrumentation System Using Acquisition Mechanism for BLDC-Powered Electric Vehicle. *Jurnal Ilmiah Teknik Elektro Komputer dan Informatika*. 2022 Jul;8(2):235–48.
3. González A, Olazagoitia JL, Vinolas J. A low-cost data acquisition system for automobile dynamics applications. *Sensors*. 2018 Jan 27;18(2):366.
4. Bedretchuk JP, Arribas García S, Nogiri Igarashi T, Canal R, Wedderhoff Spengler A, Gracioli G. Low-cost data acquisition system for automotive electronic control units. *Sensors*. 2023 Feb 19;23(4):2319.
5. Ambrož M. Raspberry Pi as a low-cost data acquisition system for human powered vehicles. *Measurement*. 2017 Mar 1;100:7–18.
6. Liu Y, Le Clair A, Doude M, Burch VR. Development of a data acquisition system for autonomous vehicle systems. *International Journal of Vehicle Structures & Systems*. 2018 Oct 1;10(4):251–6.
7. Bari A, Bhandari S, Krishnan R, Pandharkar R. Ultra-low cost vehicle data acquisition and transfer system from analog and digital sensors to audio channel of a phone. In *16th International Conference on Advanced Communication Technology 2014 Feb 16 (pp. 698–704)*. IEEE.

- 
8. Sidik, M.A.B.; Arifin Rusli, M.Q.; Adzis, Z.; Buntat, Z.; Arief, Y.Z.; Shahroom, H.; Nawawi, Z.; Jambak, M.I. Arduino-Uno based mobile data logger with GPS feature. *Telkomnika Telecommun. Comput. Electron. Control* **2015**, *13*, 250–259
  9. Cervantes-Villanueva, J.; Carrillo-Zapata, D.; Terroso-Saenz, F.; Valdes-Vela, M.; Skarmeta, A.F. Vehicle maneuver detection with accelerometer-based classification. *Sensors* **2016**, *16*, 1618.
  10. Andria G, Attivissimo F, Di Nisio A, Lanzolla AM, Pellegrino A. Development of an automotive data acquisition platform for analysis of driving behavior. *Measurement*. 2016 Nov 1;93:278–87.