

Human–Machine Interaction in Advanced Driver Assistance Systems: Design and Evaluation

Shravani Akude^{1,*}, Tejas Bhete², Sayali Gaikwad³, Nilesh Bhaskar⁴

Abstract

An autonomous vehicle, also known as a self-driving car, is one that is equipped with sensors and cameras to monitor its environment and that can operate independently without the need for human intervention. It recognizes objects in the immediate environment, such as people, animals, and barriers, using a combination of cameras and sensors. reducing fuel waste, improving mobility, safety, and customer pleasure, among other things. Cost savings is one advantage of owning an autonomous vehicle. There will be fewer injuries and accidents as well as lower insurance costs as a result of the safety benefits. The primary objective of advanced driver assistance system (ADAS), a technological innovation in the automotive sector, is to enhance driving comfort and safety. Its primary goals are to assure uniform driving by recognizing lanes using computer vision, enhance traffic flow by detecting traffic signals, decrease crashes with radar and lidar-assisted protection, and promote cautious driving through detection. By fusing these functions, ADAS aims to revolutionize driving behavior, which will ultimately lower accident rates and make driving safer and more enjoyable. With the goal of having a major influence on the creation of intelligent and safe vehicles, ADAS has been positioned as a leader in the development of automotive technology.

Keywords: Traffic sign recognition, lidar, image processing, vehicle safety, driver assistance system

INTRODUCTION

An autonomous vehicle, sometimes referred to as a self-driving car, is one that runs on its own without the need for human assistance and has sensors and cameras to analyze its surroundings. It uses a mix of cameras and sensors to recognize items in the surrounding area, including pedestrians, animals, and barriers, thus lowering fuel waste, raising consumer satisfaction, safety, and mobility, among other things. One benefit of having an autonomous car is that it can reduce expenses. Because of the safety benefits, there will be fewer accidents, fewer injuries, and a reduction in insurance costs

[1]. By facilitating frequent travel, as well as providing transportation for the elderly, crippled, children, and the impoverished who are unable to work without it, driverless cars can reduce traffic. By transforming current automobiles into autonomous vehicles, travelers can lessen the stress of driving and navigational problems when visiting foreign cities, as well as lessen the demand for parking, fuel consumption, and crime. The areas in which semiconductor technology has been demonstrated to provide low-voltage drives are listed in this article. The study also identifies a number of areas that semiconductors in the automobile industry are facing serious hurdles, as well as various prospects for future innovation. The advantages of employing vehicle signaling

*Author for Correspondence

Shravani Akude
E-mail: shravani6akude@gmail.com

¹⁻³Students, Department of Electronics and Telecommunication Engineering, Sinhgad College of Engineering, Pune, Maharashtra, India

⁴Professor, Department of Electronics and Telecommunication Engineering, Sinhgad College of Engineering, Pune, Maharashtra, India

Received Date: May 01, 2024

Accepted Date: May 15, 2024

Published Date: May 28, 2024

Citation: Shravani Akude, Tejas Bhete, Sayali Gaikwad, Nilesh Bhaskar. Human–Machine Interaction in Advanced Driver Assistance Systems: Design and Evaluation. Journal of Microelectronics and Solid State Devices. 2024; 11(1): 1–8p.

algorithms as a crucial component of toll road traffic management are investigated in this work. The pictures were taken with an action camera that was mounted on the car's roof. Python 3 is a graphical programming language. It offers color space, texture selection, object recognition, and HOG (histogram of oriented gradients) methods [2, 3].

Deep learning–based autonomous vehicles are being actively promoted by researchers and developers in the automobile industry. Before neural networks are widely employed in cars, they must pass security testing. The possibilities and difficulties of using deep learning to driverless cars are covered in this paper. From motor vehicles to controlled vehicles, a wide range of vehicles are divided into different SAE (Society of Automotive Engineers) categories. We refer to these vehicles as semi-autonomous cars. These were developed prior to the introduction of complete automation. These are repeated procedures, like automating some parts of a vehicle that is semi-autonomous. Despite having some autonomous car characteristics, these semi-autonomous cars may still allow the driver to take control of the vehicle. Passengers can travel in fully automated cars since the majority of them use pre-programmed codes. Secondary data that needs to be processed are traffic lights and the instantaneous recognition of pedestrians on the road. When putting on a stop signal, certain people—including police officers—might find it difficult to distinguish between specific objects, like cars, garbage lights, or garbage cans. There is no way to avoid stones on the road because it is impossible to see them while driving. With their superior vehicle control and ability to see farther than humans, these cars may benefit from higher speed restrictions and improved ride comfort. Because there is less need to safely divide vehicles at high speeds, this expands the capacity of the road and lowers the number of traffic accidents [4].

At the moment, cars on the highway are 40 to 50 m (130–160 feet) apart from the car in front of them. One of the main reasons for accidents, especially in large cities where traffic congestion is heavier in some areas, may be this road's increased capacity. Whenever higher authorities try to regulate traffic, it usually results in more violence since they have access to more information and can forecast people's driving habits. We outline the autonomous system design utilized in driverless cars in this study. We also examine studies on comprehension and decision-making processes. Furthermore, we present a synopsis of the intelligent autonomous robot car (IARC) design, an autonomous vehicle created by the Federal University of Espirito Santo (UFES). Lastly, we include a summary of the most significant automotive research reports that have been released by technological corporations, academic institutions, and media outlets. The white line can be found using a variety of algorithms, such as ones that look for a self-driving car on the road. While numerous systems with different purposes for self-driving cars have been developed in the literature, no hardware-based microsystem is able to carry out all of these tasks [5–7].

OBJECTIVE

1. The goal of advanced driver assistance systems (ADAS) is to increase vehicle safety by offering the driver extra help and support in a variety of driving scenarios. The following are some of the primary objectives of ADAS.
2. *Accident prevention:* By alerting users or taking action when there are hazards, such as cars, pedestrians, or obstructions, ADAS systems help avoid or lessen the likelihood of accidents.
3. *Driver assistance:* By helping with tasks like parking, lane maintenance, cruise control, and traffic assistance, ADAS lessens the amount of time that drivers are occupied and fatigued. *Emergency response:* By delivering emergency notifications or putting safety precautions like braking or control safety in place, ADAS systems can help emergency services.
4. *Enhanced comfort and convenience:* By focusing on particular duties and lowering driving stress, ADAS features contribute to a more enjoyable and convenient driving experience.

LITERATURE REVIEW

1. In order to assess road risk, Jiménez et al. [1] proposed an integrated collision avoidance system that combines wireless communication, 3D laser scanning, and vision.

2. Anand et al. [2] examine how ADAS may affect upcoming cars and draw attention to the variations between systems utilized in India and other countries.
3. Wang et al. [3] provide an algorithm for image processing that makes use of the cone to enhance the color and depth of the image.
4. Kukkala et al. [4] explore the development of ADAS and emphasize how crucial it is for drivers to comprehend and have faith in these systems.
5. Road signs in particular can be used to solve the image capture problem using machine learning, according to Lghoul [6].

BLOCK DIAGRAM

Block diagram of the proposed system is shown in Figure 1.

METHODOLOGY

The groundbreaking advancement in automotive technology known as advanced driver assistance systems, or ADAS, aims to decrease accidents, increase driver comfort, and improve road safety. These systems let cars to be aware of their surroundings and make wise judgments while driving by utilizing cutting-edge technology like sensor fusion, computer vision, and machine learning. ADAS technology is a crucial link that offers insight into the future of transportation as the car industry makes the shift to autonomous driving.

This section outlines the methodology utilized in the development and deployment of ADAS. This method covers the development, testing, and use of intelligent systems in automobiles. In order to guarantee dependability, accuracy, and security, it entails the combination of hardware, software development, algorithm design, and rigorous testing processes.

Problem Definition and Needs Analysis

ADAS functions should be defined in accordance with business, security, and monitoring criteria. Analyze implementation plans thoroughly to find issues and constraints.

Sensor Integration

Utilize a variety of sensors, including lidar, radar, cameras, and ultrasonic sensors, to gather information about the environment around the vehicle in real time. For accuracy and dependability, synchronize and calibrate sensor data.

Data Collection and Description

Gather a number of datasets that represent a range of weather, driving circumstances, and environmental factors. Implement data gathering to build a database that will be used to train machine learning models.

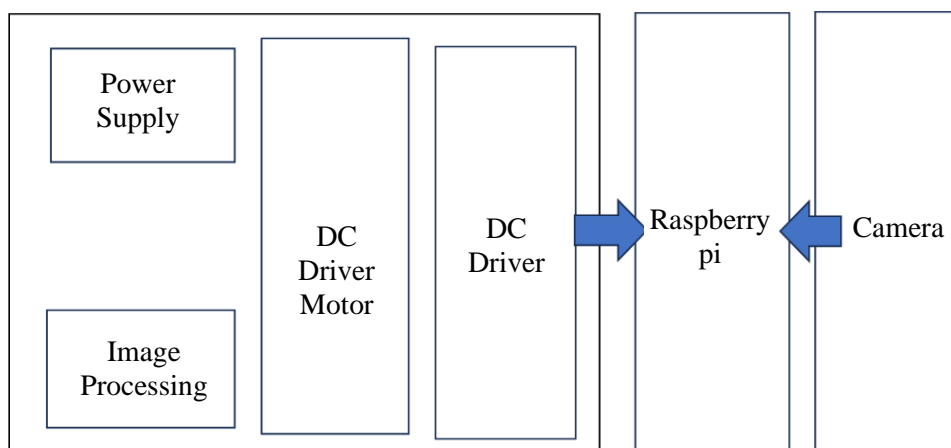

Figure 1. Block diagram of the proposed algorithm.

Algorithm Development

Create and use computer vision algorithms to applications including semantic classification, vehicle recognition, lane detection, and object detection. Utilize deep learning and other machine learning techniques to carry out difficult tasks like anomaly detection and behavior prediction.

Sensor Fusion and Sensing

Utilize sensor fusion algorithms to integrate sensor data and produce an accurate and thorough depiction of the vehicle's surroundings. Create cognitive algorithms that can recognize objects, lines, people, and other pertinent information by interpreting aggregated sensor data.

Software System Design of AI-based Advanced Driver Assistant System

Operating system (OS) layer

Memory and I/O interfaces are examples of hardware and control devices that microcontrollers have little effect on. Establish a development environment.

Drive system

The drive system offers drive software for hardware components such as toggle switches for servo motors, geared DC motors, and H-bridge DC motor drives.

System control

System control is in charge of anti-interference, sophisticated control, and algorithm adaptation for engine control, among other duties. Utilize sensing devices to ascertain the vehicle's behavior.

User interface layer

The user interface layer offers an intuitive user interface for the tool's interaction. the capacity to monitor sensor data, adjust vehicle movement, and get feedback. Python is used in software development, while Raspberry Pi libraries are used to power the sensor and actuator. Several open source libraries and scripts provide various iterations of the vehicle.

Raspberry Pi 3 Model B+

With a Broadcom BCM2837B0 Cortex-A53 64-bit SoC @ 1.4 GHz, 1 GB LPDDR2 SDRAM, 2.4 GHz and 5 GHz IEEE 802.11.b/g/n/ac wireless LAN, Bluetooth 4.2, BLE, and more, the Raspberry Pi 3 model B+ is the last iteration in the Raspberry Pi 3 line [8]. Raspberry Pi model is shown in Figure 2.

H- Bridge DC Motor Driver

The L298N Dual H-Bridge Motor Controller is a well-liked option for regulating the rotational direction and motor speed. Motors rated for 5 to 35 V can be powered by it up to 2 A [9]. Model of motor driver is shown in Figure 3.



Figure 2. Raspberry Pi.

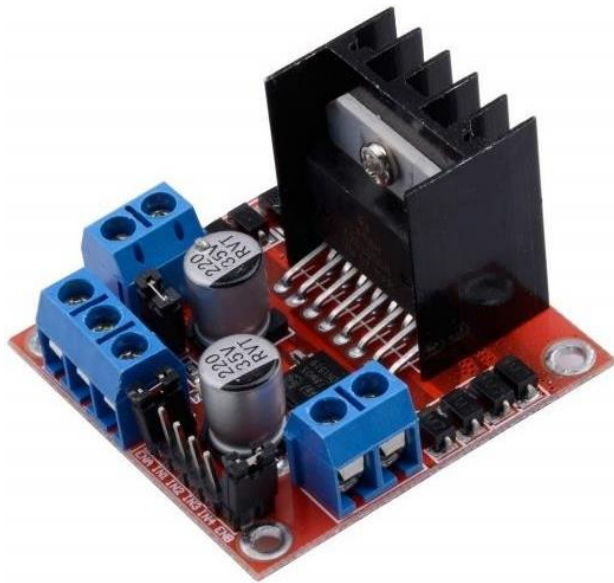

Figure 3. Motor driver.



Figure 4. Pi camera.



Figure 5. DC motor.

Pi Camera

With its compact form, the high-definition camera module offers low noise, low crosstalk, and high sensitivity picture capture for all Raspberry Pi models [10]. Pi Camera model is shown in Figure 4.

Geared DC Motor

A gearbox-equipped geared DC motor lowers speed and boosts torque output to provide a load more power. DC motor model is shown in Figure 5.

Car Chasis KiT

Using the chassis, wheels, and motor systems of a remote controlled (RC) car, a robot with movement and control capabilities can be constructed on top of an RC car chassis [11]. Car chassis kit model is shown in Figure 6.

Power Bank

Portable charging stations known as power banks are used to replenish USB-powered gadgets such as headphones, Bluetooth speakers, and cellphones. Power bank model is shown in Figure 7.



Figure 6. Car chassis kit.



Figure 7. Power bank.

APPLICATIONS

By enabling more efficient driving, ADAS promise to boost road safety, enhance autonomous driving, and benefit the environment. They can shorten travel times, lessen traffic, and enhance traffic management. Because of the economic effects, which include chances for skill and vehicle management improvement as well as job losses in the driving business, continuous safety monitoring is crucial.

RESULTS

The research's technique and focus will determine the particular findings of any given article. Several inferences or discoveries drawn from the given data could be:

1. Assess how well ADAS technologies like lane detection and traffic awareness contribute to increased comfort and safety when driving.
2. Learn about the advantages of driverless cars, such as decreased insurance costs, fewer accidents, better traffic, and more mobility for specific populations.
3. Talk about how semiconductor technology helps to make ADAS and autonomous driving a reality. Explore the challenges and safety considerations, as well as the application of deep learning techniques to driving-related tasks.
4. Examine the effects of varying degrees of vehicle autonomy (such as fully autonomous and semi-autonomous) on control and assistance for drivers.
5. Give an explanation of the development and design of the electronic systems used in autonomous cars, along with a brief history of science and technology.

CONCLUSION

To sum up, ADAS driven by artificial intelligence mark a significant advancement in automobile technology and have the potential to enhance driving and road safety. Parking assistance, driver recognition, semi-automated driving, collision avoidance, and driver monitoring are all made possible by artificial intelligence. By identifying the surroundings, alerting users to possible dangers, and even initiating corrective action, this technology employs artificial intelligence to lower the number of accidents caused by human mistake. The total performance of these systems is improved by combining various data types using artificial intelligence-based data fusion, underscoring the critical role that drivers play in enhancing safety and simplifying the future.

Acknowledgements

We express our gratitude to everyone who contributed to the success of the most advanced artificial intelligence-based driver assistance service. The success of this project would not have been possible without the cooperation, expertise and support of many people.

Special thanks to Professor N. G. Bhaskar for providing necessary resources and support. The dedication and hard work of the entire team helped turn the ideas into reality. We thank the experts and consultants for their valuable collaboration during planning and implementation.

REFERENCES

1. Jiménez F, Eugenio J, Anaya JJ, García F, Ponz A, Armingol JM. Advanced driver assistance system for road environments to improve safety and efficiency. *Transport Res Procedia*. 2016; 14: 2245–2254.
2. Anand A, Manoj Kumar A, Naresh K, Janakiraman G. Research study on advanced driver-assistance systems (ADAS) – global & Indian automotive scenario. *Int Res J Modern Eng Technol Sci*. 2021; 3 (11): 564–568.
3. Wang L, Sun P, Xie M, Ma S, Li B, Shi Y, Su Q. Advanced driver-assistance system (ADAS) for intelligent transportation based on the recognition of traffic cones. *Adv Civil Eng*. 2020; 2020: Article 8883639.
4. Kukkala VK, Tunnell J, Pasricha S, Bradley T. Advanced driver-assistance systems: a path toward autonomous vehicles. *IEEE Consumer Electron Mag*. 2018; 7 (5): 18–25. doi: 10.1109/MCE.2018.2828440.

-
5. Ziebinski A, Cupek R, Grzechca D, Chruszczyk L. Review of advanced driver assistance systems (ADAS). *AIP Conf Proc.* 2017; 1906: 120002. doi: 10.1063/1.5012394.
 6. Lghoul R, Advanced driver assistance systems using AI. In: *Proceedings of the 5th WSEAS International Conference on Signal Processing, Robotics and Automation (ISPRA)*, Madrid, Spain, February 15–17, 2006. pp. 295–300.
 7. Biondi FN, Getty D, McCarty MM, Goethe RM, Cooper JM, Strayer DL. The challenge of advanced driver assistance systems assessment: a scale for the assessment of the human–machine interface of advanced driver assistance technology. *Transport Res Rec.* 2018; 2672 (37): 113–122.
 8. Takada Y, Boer ER, Sawaragi T. Driver assist system for human–machine interaction. *Cognit Technol Work.* 2017; 19 (4): 819–836.
 9. Mendoza PA, Angelelli A, Lindgren A. Ecological interface design inspired human machine interface for advanced driver assistance systems. *IET Intell Transport Syst.* 2011; 5 (1): 53–59.
 10. Albers D, Radlmayr J, Loew A, Hergeth S, Naujoks F, Keinath A, Bengler K. Usability evaluation—advances in experimental design in the context of automated driving human–machine interfaces. *Information.* 2020; 11 (5): 240.
 11. Tan Z, Dai N, Su Y, Zhang R, Li Y, Wu D, Li S. Human–machine interaction in intelligent and connected vehicles: a review of status quo, issues, and opportunities. *IEEE Trans Intell Transport Syst.* 2021; 23 (9): 13954–13975.