

# Analysis of Thermal Performance Improvement of Engine Fins by Varying the Materials and Profiles Used at High Temperatures

Pallepogu Naveen<sup>1,\*</sup>, Sri. M. Kumara Swamy<sup>2</sup>

## Abstract

*In this study, we designed fins using various profiles and materials to identify the optimal combination for a 100cc engine. We also tested different fin materials to evaluate the heat efficiency of the engine. Our study involves a comparison between the optimized fins and the original aluminum fins currently used. To ensure the optimal performance of the 100cc engine, we utilized advanced analytical software to thoroughly analyze the results from our simulations. This analysis will help us identify the most efficient fin design for engine cooling, which will then be further optimized using ANSYS. A key focus of this study is to test and evaluate the performance of four different materials: Al 6082, magnesium alloy, Al + SiC-12, and Al 8011A. These materials were analyzed in combination with varying fin profiles and adjusting their shapes to enhance heat dissipation. The design phase of the single-cylinder block was conducted using CATIA, in which different fin arrangements were created. Subsequently, ANSYS was employed to perform a detailed analytical analysis, allowing us to assess the thermal performance of each design and material combination. This iterative process ensures that the most efficient configuration of materials and fin profiles is achieved, leading to an improved engine cooling efficiency.*

**Keywords:** Material comparison, single-cylinder block, thermal analysis, materials testing, engine cooling

## INTRODUCTION

In an internal combustion (IC) engine, combustion occurs at high temperatures, and as engine capacity increases, the piston may seize owing to excessive heat and pressure within the cylinder, leading to engine failure [1]. Higher engine temperatures can result in greater damage to the pistons, piston rings, and engine blocks. To prevent this, air cooling is used, particularly in small engines, by employing fins [2]. Air-cooled engines dissipate heat through forced convection by utilizing atmospheric temperatures. The rate of heat dissipation depends on the wind flow and the geometry of the cylinder fins.

### \*Author for Correspondence

Pallepogu Naveen

E-mail: itsmenaveenproject1999@gmail.com

<sup>1</sup>Student, Department of Mechanical Engineering, Thermal Engineering from Jawaharlal Nehru Technological University Kakinada, Andhra Pradesh, India

<sup>2</sup>Associate Professor, Department of Mechanical Engineering, Jawaharlal Nehru Technological University Kakinada, Andhra Pradesh, India

Received Date: August 07, 2024

Accepted Date: September 10, 2024

Published Date: September 14, 2024

**Citation:** Pallepogu Naveen, Sri. M. Kumara Swamy. Analysis of Thermal Performance Improvement of Engine Fins by Varying the Materials and Profiles Used at High Temperatures. International Journal of Energy and Thermal Applications. 2024; 2(1): 36–46p.

In this study, we focused on analyzing the engine fins mounted on the outer surface of the engine block. The analysis considered the internal engine temperature and external forced convection acting on cylinder fins. Many current engine designs are outdated and require improvement to meet modern environmental demands [3]. Research on current engines has revealed that most engines are manufactured using materials such as Al 360F, with some high-standard companies using Al 1100, Al 6061, and Al 6082 [4].

Our research will explore composite materials that can offer improved efficiency and thermal performance compared to previous materials. Additionally, we will investigate how altering the fin profiles of a single-cylinder engine without changing the cylinder dimensions can enhance performance [5, 6]. This approach aims to achieve better results for both the fin profiles and materials used in the project.

### **Natural Air Cooling**

Natural air-cooled engines are commonly used in smaller and lower-capacity engines, typically two-wheeler and three-wheeler vehicles [7]. In large engines, the power output is significantly higher, resulting in greater heat generation during combustion, which exceeds the normal atmospheric temperature [1]. The cooling method used in air-cooled engines is referred to as natural convection or air cooling [8]. Most engines currently in use rely on this air-cooling system. Engine fins play a crucial role in enhancing the rate of heat dissipation and are arranged on the surface of the cylinder block to facilitate this process [4, 9].

### **LITERATURE REVIEW**

Naman Sahu, Vishal Gupta, Pradeep Kr. Kurmi [1] has done research that focused on an engine cylinder and its components under high temperatures, where significant temperature fluctuations and thermal stress occur. In this study, cylinder fins were redesigned to enhance the heat transfer rate. Thermal analysis was employed to evaluate the results because this approach provides valuable insights into the performance of the cylinder and engine fins. This study draws upon previous studies to deepen the understanding of the heat transfer rate of engine fins, recognizing that the outcomes vary based on the different fin designs used. In this study, we aimed to determine the heat transfer rates of various fin materials and geometries under high-temperature conditions [1].

Mulukuntla Vidya Sagar and Nalla Suresh [2] have done research that focused on an engine cylinder to examine thermal stress and temperature variations. The primary objective of this study is to determine the thermal properties and heat flux distribution by altering the fin profiles using both circular and rectangular geometries and testing materials, such as aluminum and magnesium alloys. In addition, the thickness of the fins was modified using the SolidWorks software. Transient thermal analysis was performed to validate the results using ANSYS software [2].

Kumar Patel and Kumhar conducted research involving the analysis of an IC engine block using the ANSYS software. ANSYS was employed to simulate the operations and compare the thermal effects through a thermal analysis. CATIA software was used to design the IC engine model. The analysis focuses on the cylinder block by varying the fin cross-sections. Different fin profiles have been utilized to optimize and reduce the heat transfer rates [3].

Sachin Kumar Gupta, Harishchandra Thakur, and Divyank Dubey have done this study on the surveys of engine parameters by varying the materials used in engine manufacturing. Engine performance is largely influenced by the fins and materials employed. The primary objective of this study is to improve the thermal properties, such as the temperature distribution and heat flux, by adjusting the fin profiles and materials that affect these properties. A 3D model was created using the SolidWorks software, keeping the number and thickness of the fins constant while varying the slot sizes. Currently, Al A204 alloys are commonly used on the market. In this study, we optimized the material to include Al 6061, Al C443, and Al 2014 alloys. The results indicated that 75 mm slotted fins made of aluminum 2014 alloy achieved the highest heat transfer rate, whereas slot sizes above 75 mm resulted in a decrease in heat transfer efficiency [4].

### **PROBLEM STATEMENT**

Many motorcycles on Indian roads use air-cooled engines because of their low capacity, which makes them suitable for air cooling [10]. Although air-cooled engines have been successfully designed in the

past, they require significant improvements to meet modern temperature standards and ensure functionality for the next 20 years. A major issue is the change in geographical weather patterns, with notable temperature increases over the past 20–25 years. Future-proof engine designs must be able to address these evolving conditions. Figures 1–3 illustrate an analysis using various materials, including alloys and composites, to explore how they influence the performance.

### Design Images of the Project

Figures 1–3 illustrate three distinct models designed using CATIA software, where modifications were made to the fin profiles to improve the performance outcomes. In modified model 1, the fins were trimmed based on the heat dissipation patterns and heat evaporation results obtained from the original design. The trimming of the fins was aimed at enhancing the airflow directly toward the outer surface of the cylinder block, thereby allowing for more efficient cooling.

In model 2, a different approach was adopted by reshaping the rectangular fins into a circular form with a tapered trim extending from the top to the bottom portion of the fins. This tapering allowed the airflow to reach the outer surface of the cylinder block more effectively, facilitating a smoother passage of air and better heat dissipation. By modifying the fins in this manner, we aim to increase the contact area between the fins and surrounding air, thereby improving the overall cooling performance of the engine.

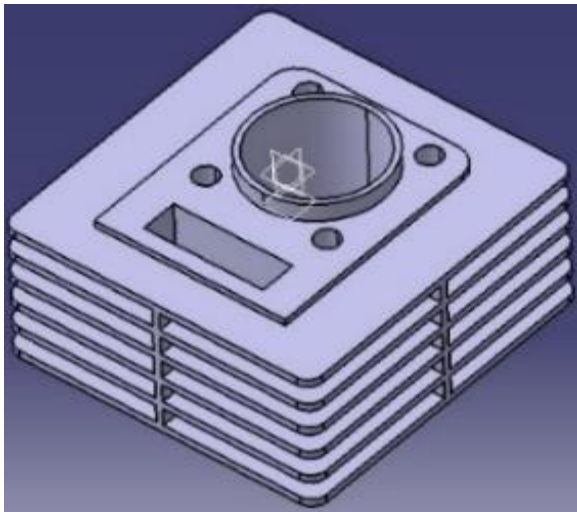

**Figure 1.** Original model.

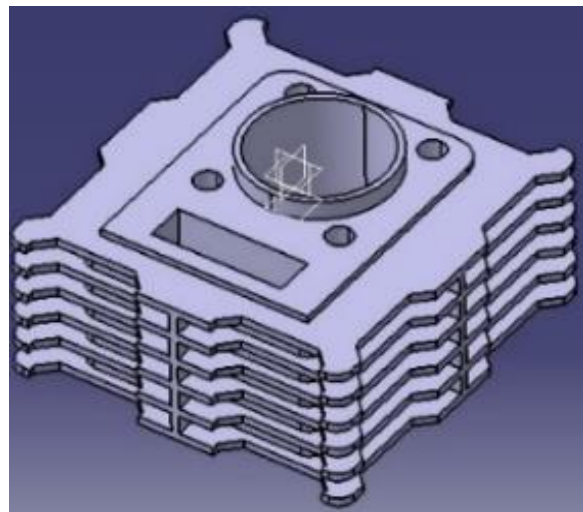

**Figure 2.** Modified 1 model.

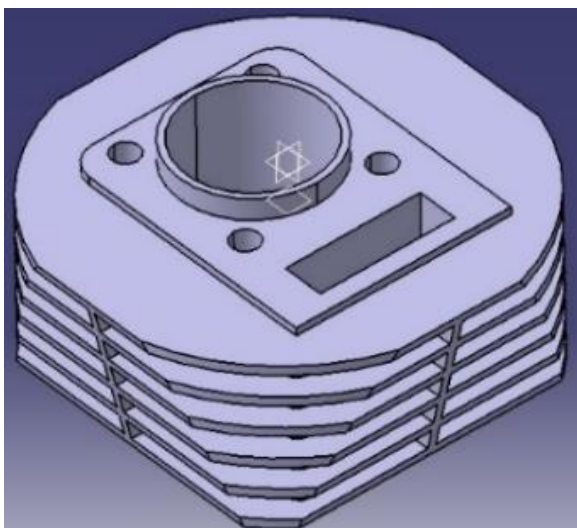

**Figure 3.** Modified 2 model.

These design variations are expected to enhance the thermal efficiency of the engine by optimizing the fin profiles to maximize airflow and heat transfer. Further analysis is required to compare the performance of these models under real-world conditions; however, the initial results suggest that these modifications could lead to significant improvements in cooling and engine longevity.

#### ANALYSIS OF ORIGINAL MODEL USING Al 6082 MATERIAL

Figure 4 illustrates the meshed model generated in the ANSYS software after completing the geometry step. In this process, the model is divided into smaller elements, which in turn creates numerous nodes and elements. The larger the number of nodes and elements, the more precise and accurate the results. Meshing plays a crucial role in the accuracy of simulation results by dividing the geometry into discrete sections. This process is generally performed using various methods, including quadrilateral, prism, triangular, and hexamesh techniques.

In our study, we specifically used the triangular meshing method. This choice was made to ensure that the results obtained were as accurate and detailed as possible, considering the complexity of the analyzed engine model. The triangular mesh is particularly effective in capturing finer details in the geometry and is well suited for curved or irregular surfaces, making it ideal for our analysis. As demonstrated in Figure 4, this method enhances the overall precision of the simulation, providing reliable data that will help us draw meaningful conclusions from thermal analysis. By focusing on a triangular mesh, we aimed to maximize the accuracy and effectiveness of our research outcomes.

Figure 5 illustrates the temperature distribution across the original geometry using Al 6082. Similarly, Figures 6 and 7 provide insights into the heat flux and directional distribution of the heat flux for the original geometry with Al 6082. Figures 5–7 collectively show how heat is managed and dispersed within the geometry, offering a comprehensive view of the thermal performance of the selected material.

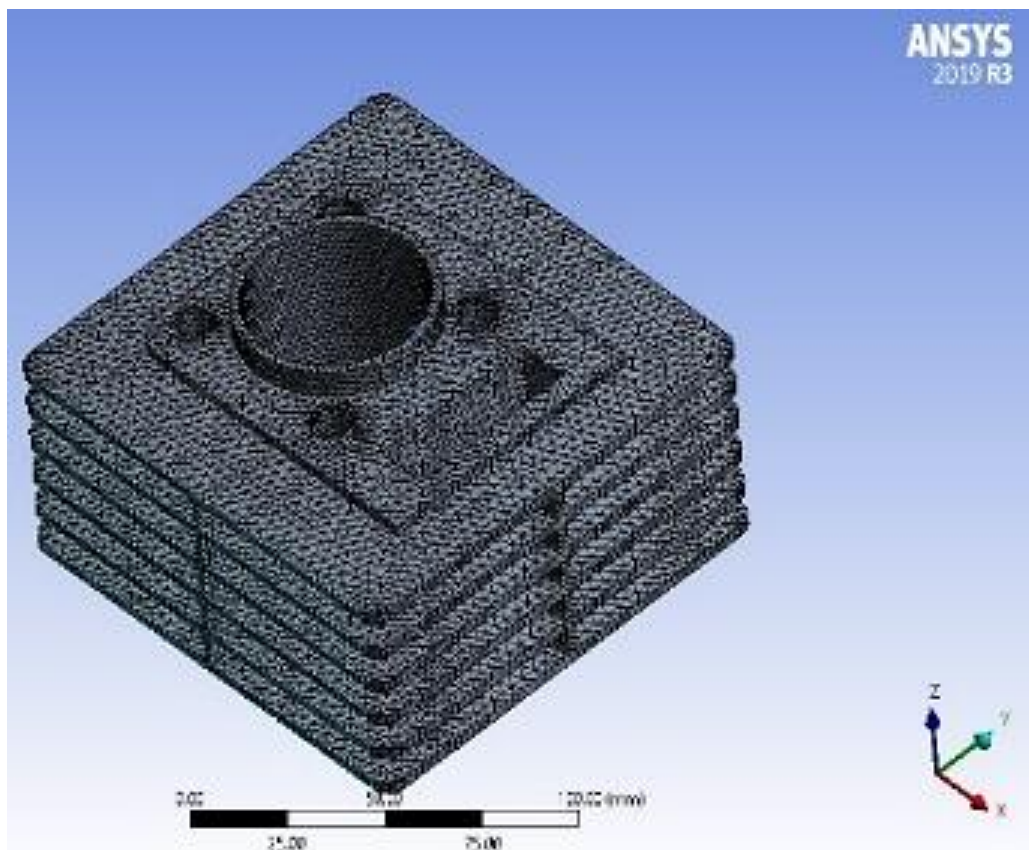

**Figure 4.** Original meshed file geometry using Al 6082.

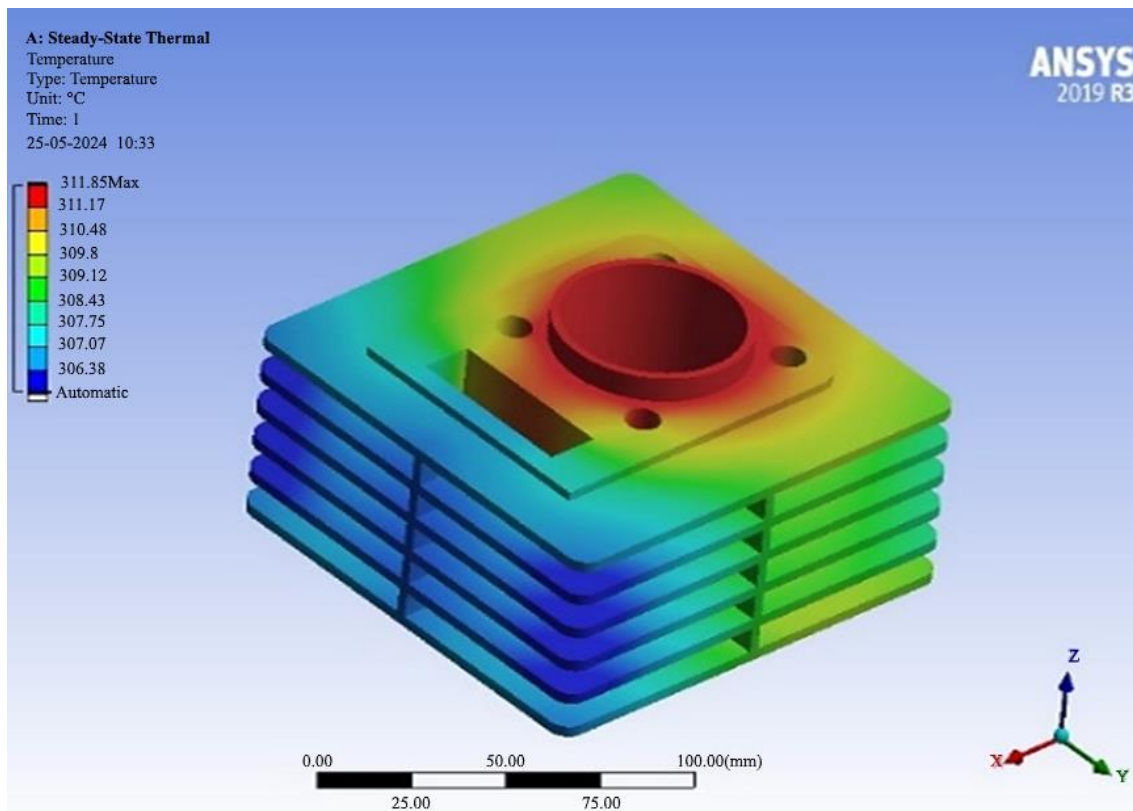

**Figure 5.** Temperature distribution across the original geometry using Al 6082.

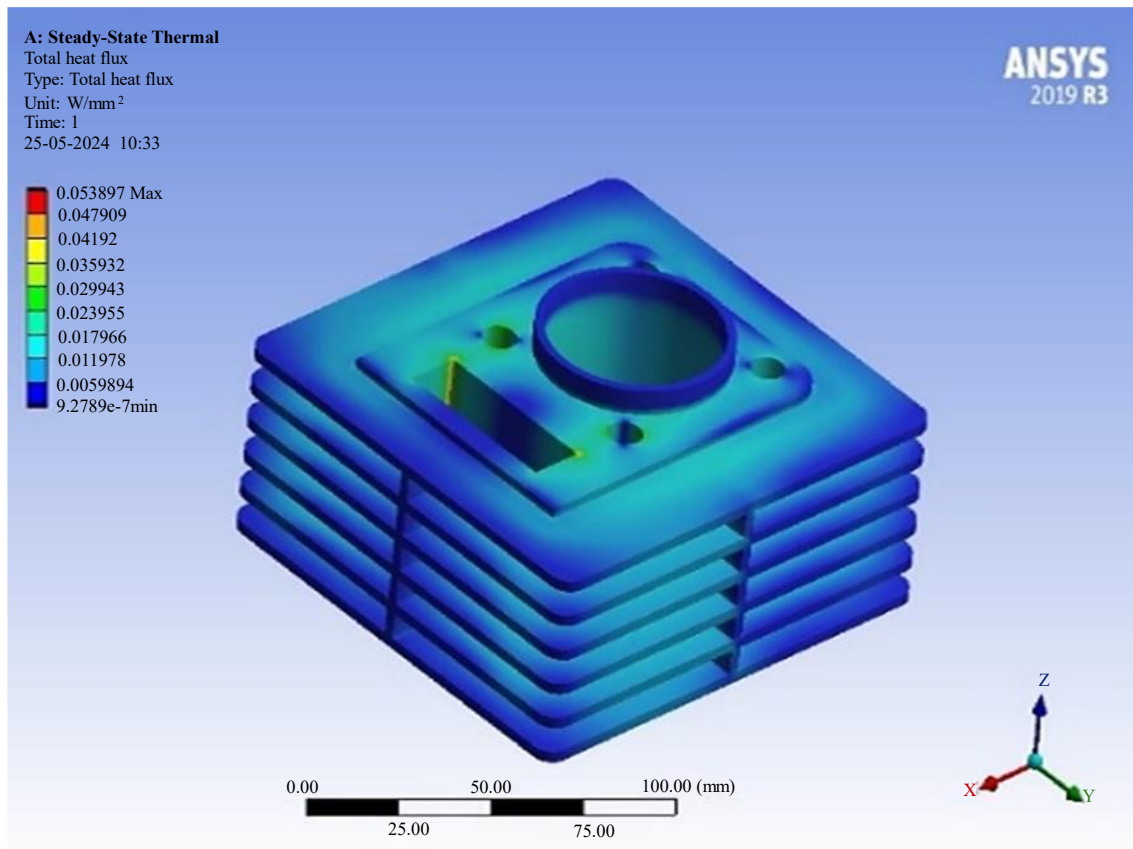

**Figure 6.** Total heat flux and directional distribution.

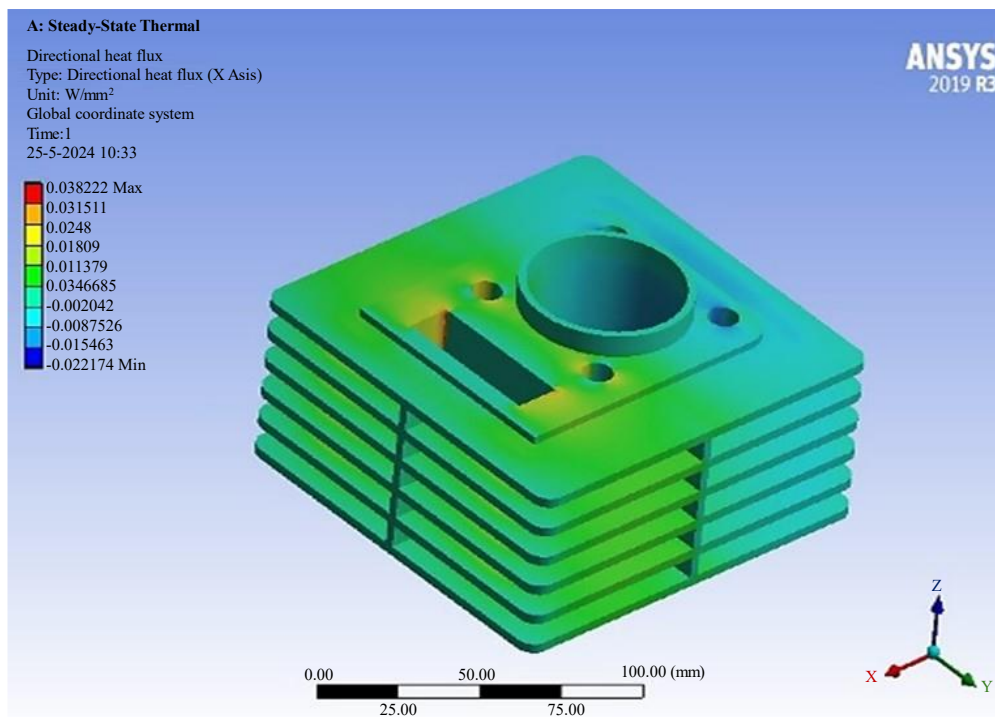

**Figure 7.** Directional heat flux and directional distribution.

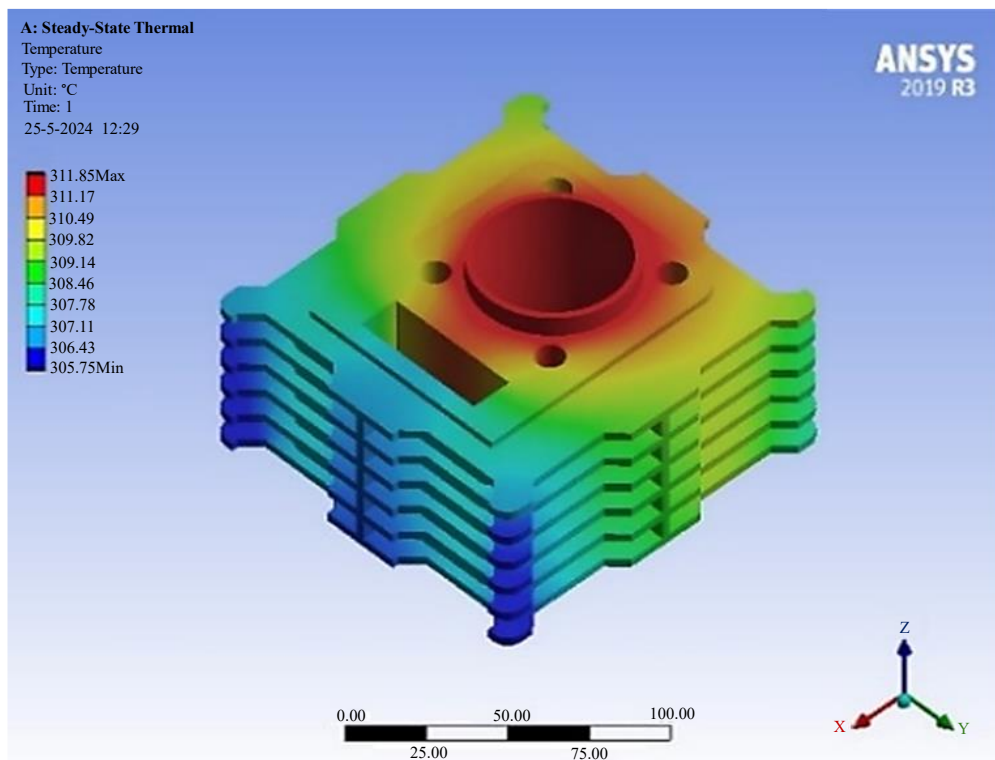
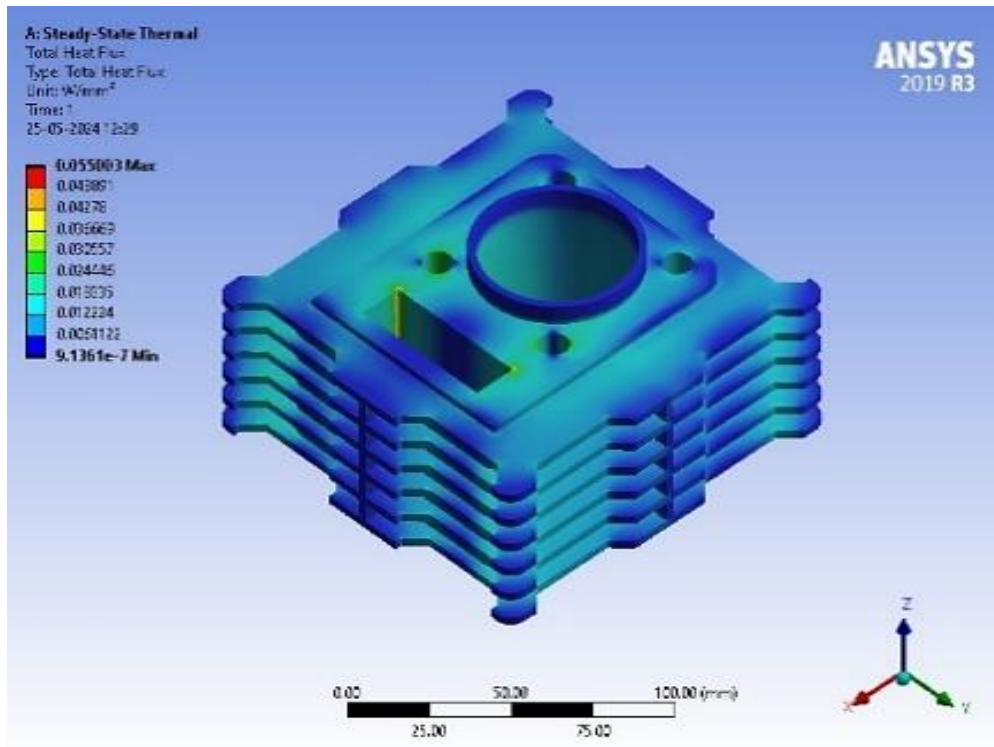

**Figure 8.** Temperature variation on blending of material.

**ANALYSIS OF MODIFIED MODEL-1 USING Al + SiC MATERIAL**

Figure 8 provides a detailed representation of the temperature distribution for the elliptical geometry when utilizing the material combination of Al 6082 and SiC. Figure 8 illustrates how the temperature varies throughout the geometry, highlighting the effectiveness of this material blend in managing the thermal conditions.

In addition, Figures 9 and 10 further elaborate on the thermal analysis by showing the heat flux and directional distribution of the heat flux within the elliptical geometry using the same material combination, Al 6082 and SiC. Figure 9 shows the overall heat flux, whereas Figure 10 provides insights into the directionality of the heat flux, revealing how heat is transferred across different regions of the geometry. Together, Figures 9 and 10 offer a comprehensive understanding of the thermal performance and distribution characteristics of the elliptical geometry with the specified materials.



**Figure 9.** Total heat flux distribution of the elliptical geometry materials.

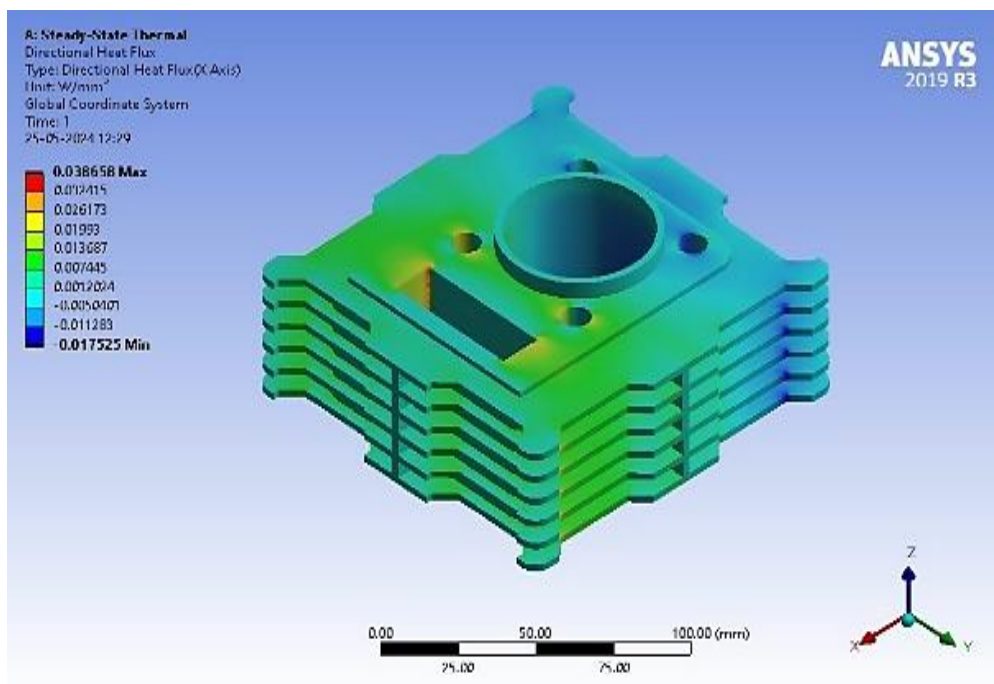
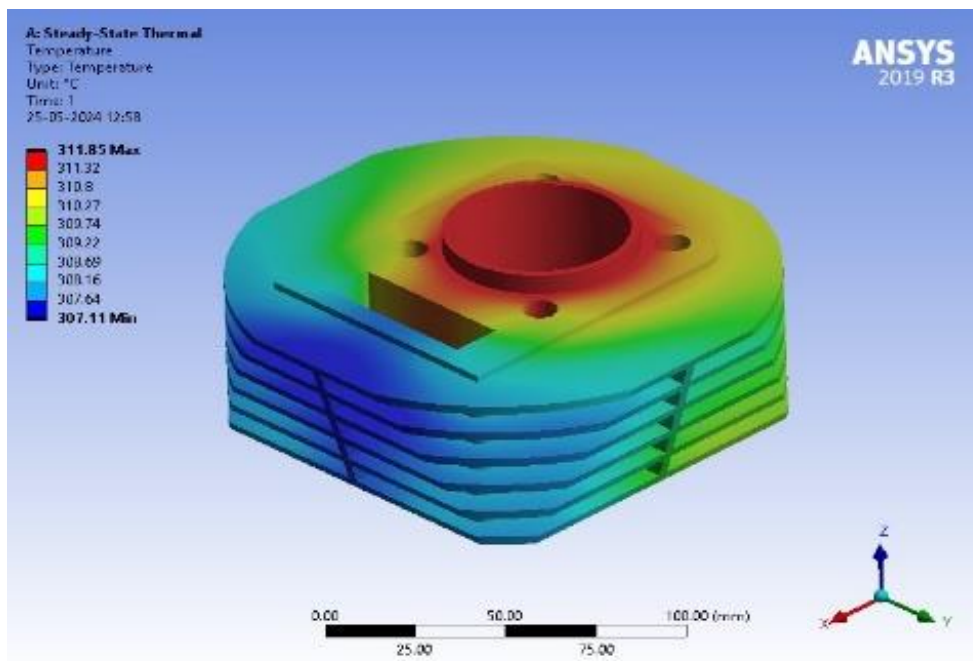

**Figure 10.** Directional heat flux of the elliptical geometry materials.

### ANALYSIS OF MODIFIED MODEL-2 USING AL 8011A MATERIAL

Figure 11 provides an in-depth view of the temperature distribution within the groove cut geometry when utilizing the Al 8011A. Figure 11 shows how the temperature varies across different areas of the groove cut geometry, demonstrating the thermal behavior and performance of this material.

Additionally, Figures 12 and 13 offer further insights into the thermal characteristics of the groove cut geometry with Al 8011A. Figure 12 illustrates the overall heat flux and Figure 13 shows the directional distribution of the heat flux. Figures 12 and 13 collectively enhance our understanding of how heat is transferred and distributed across the groove cut geometry, thereby providing valuable information on the effectiveness of Al 8011A in managing thermal conditions.



**Figure 11.** Temperature variation on the behaviour and performance of material.

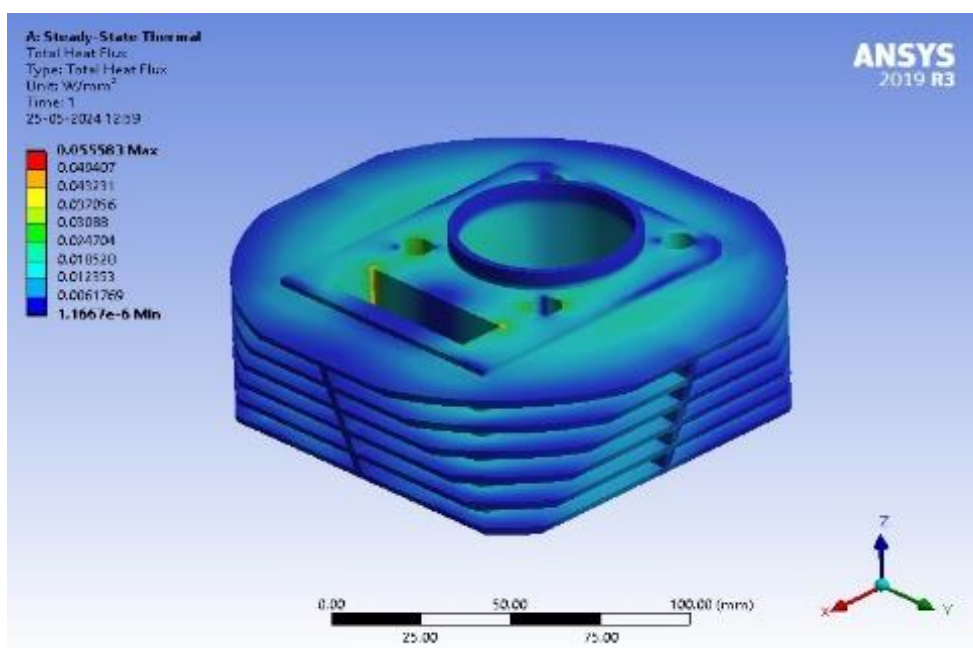

**Figure 12.** Total heat flux.

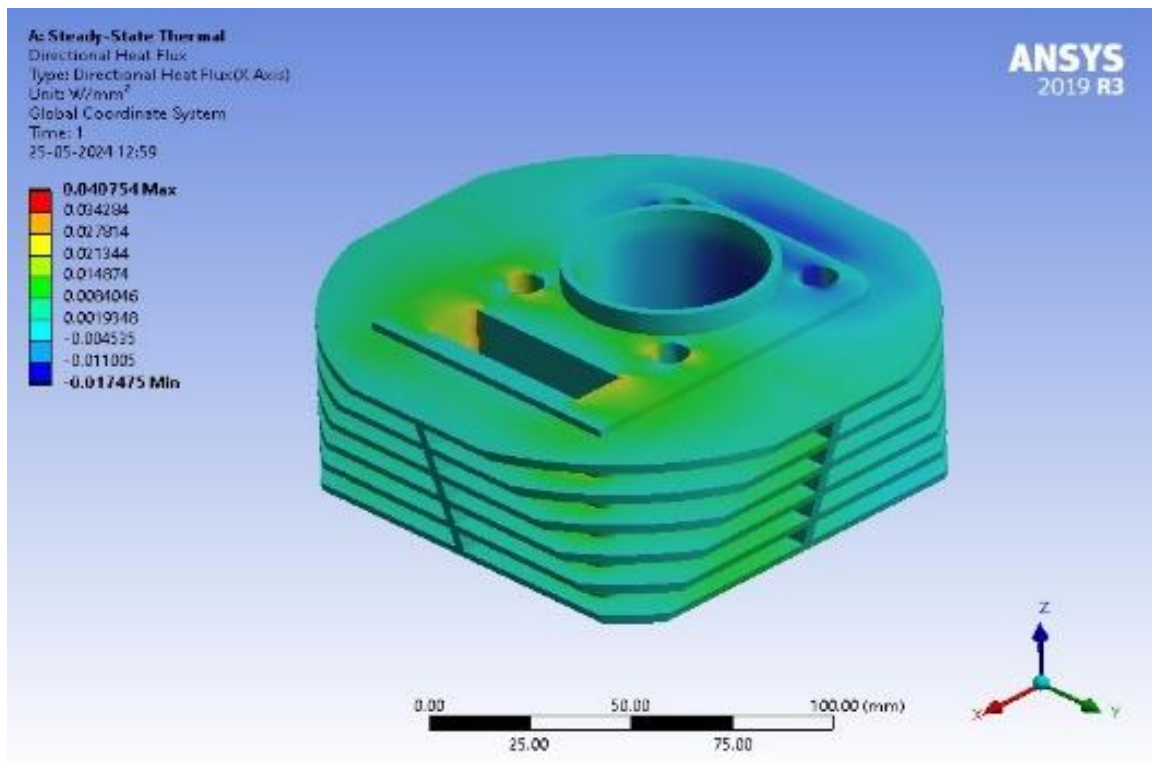

**Figure 13.** Directional heat flux.

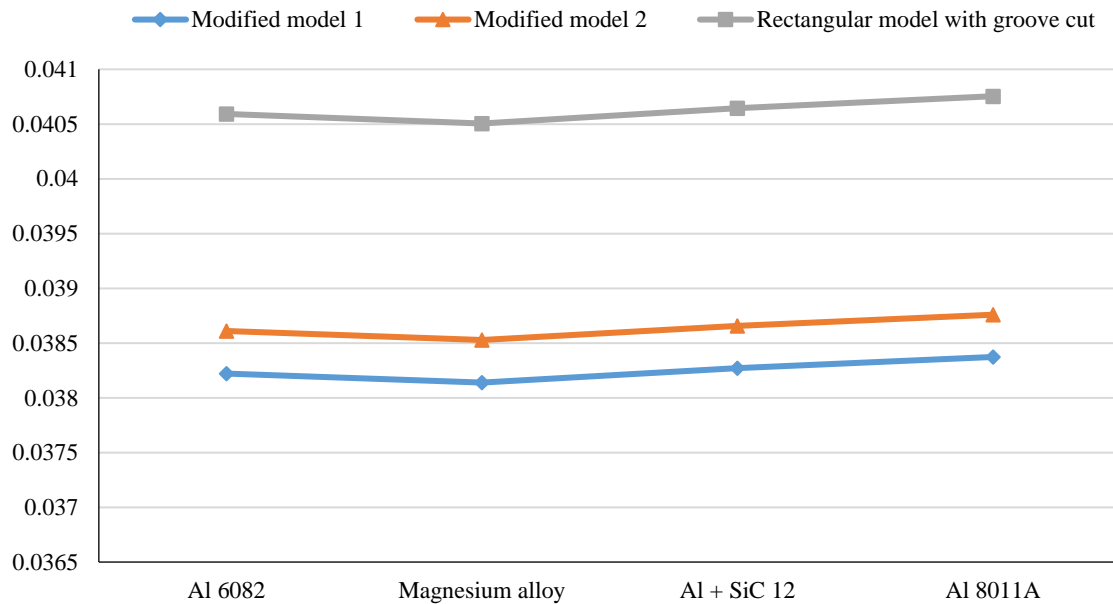
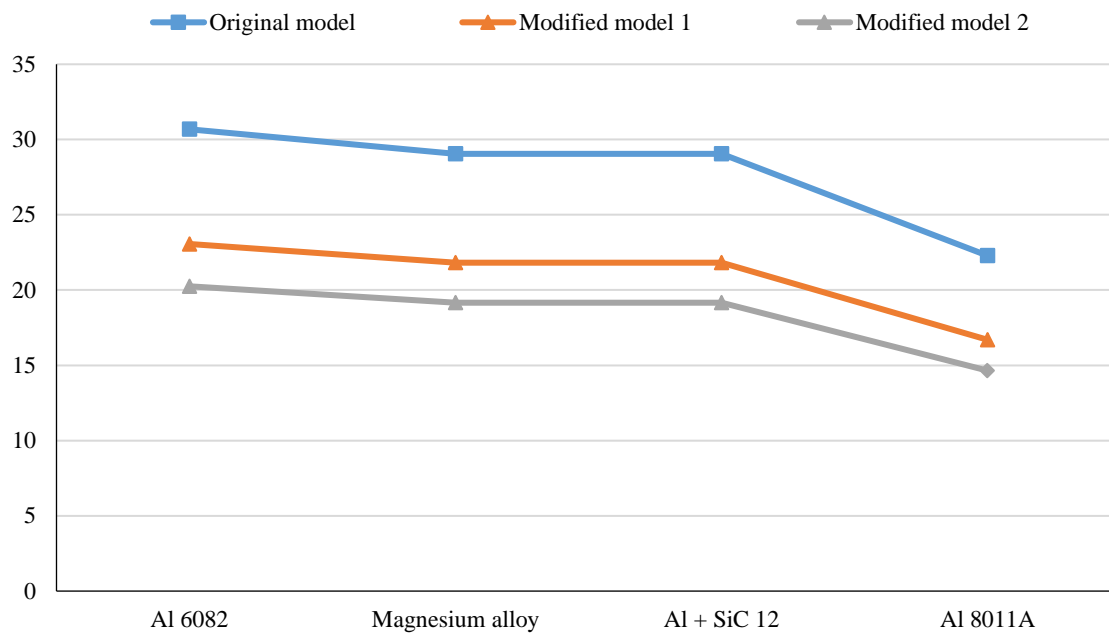

**Figure 14.** Heat flux variation.

## RESULTS AND DISCUSSIONS

The heat flux variation in Figure 14 illustrates the changes in the heat flux across the surface or the region under analysis. It provides insights into the distribution and intensity of the thermal energy flow, helping to assess the effectiveness of heat dissipation.

The directional heat flux variation in Figure 15 illustrates the changes in the heat flow direction and magnitude across the model.



**Figure 15.** Directional heat flux variation.

## CONCLUSION

In our study, we plan to design engine fins with various profiles and materials to identify the most effective combination for optimizing the performance of a 100cc engine. Our goal is to determine the material and design profile that best enhance the heat efficiency of the engine. We also tested different materials for the fins to evaluate their impact on engine performance.

To achieve this, we compared our optimized designs with the original aluminum fins that are currently in use. By analyzing the results obtained from the analytical software, we identified the best-performing model using the results from the ANSYS software. The materials under consideration were Al 6082, magnesium alloy, Al + SiC-12, and Al 8011A, and the fin profiles were optimized by varying their shapes and arrangements.

The results of our analysis are presented in both table and graph formats. Our observations indicate that the heat flux is most effectively optimized with the modified rectangular fin model using Al 8011A compared with other materials and profiles. The directional heat flux results further validate the optimal performance of the model. We also evaluated the temperature drop for all materials and found that the drop was nearly identical for both the original and optimized materials in the modified models. Based on this comprehensive analysis, the modified rectangular model using Al 8011A emerged as the most suitable choice for current conditions.

## REFERENCES

1. Sahu N, Gupta V, Kurmi PK. Thermal analysis of engine fins by using FEM: a review. *Int J Tech Innov Mod Eng Sci.* 2018;4(8):711-8.
2. Sagar MV, Suresh N. Thermal analysis of engine cylinder with fins by using ANSYS Workbench. *Int J Eng Res Technol.* 2017;6(6):502-14.
3. Patel PK, Kumhar V. Thermal analysis of piston block using finite element analysis. *Int J Innov Res Eng Multidiscip Phys Sci.* 2018;6(5):1-5.
4. Gupta SK, Thakur H, Dubey D. Analyzing thermal properties of an engine cylinder fins by varying slot sizes and material. *HCTL Open Int J Technol Innov Res.* 2015;14:1-9.
5. Sagar P, Teotia P, Sahlot AD, Thakur HC. Heat transfer analysis and optimization of engine fins of varying geometry. *Mater Today Proc.* 2017;4(8):8558-64. doi: 10.1016/j.matpr.2017.07.202.

6. Dineshan V, Pratik P, Hiren D, Raj R, Khalasi B. Design, modification and analysis of air-cooled engine fins. *Iconic Res Eng J.* 2019;2(9):144-6.
7. Patel S, Agrawal AB. Thermal analysis of engine cylinder block with fins using FEM. *Int Res J Eng Technol.* 2021;8.
8. Chaitanya PS, Rani BS, Kumar KV. Thermal Analysis of Engine Cylinder Fin by Varying Its Geometry and Material. *IOSR J Mech Civ Eng.* 2014;11:37-44. doi:10.9790/1684-11613744.
9. Wikipedia Contributors (2023). AlSiC. [online] Wikipedia. Available at: <https://en.wikipedia.org/wiki/AlSiC>
10. Chao Y, Qin S, Liu Y, Chai B. Heat exchange performance optimization of a wheel loader cooling system based on computational fluid dynamic simulation. *Adv Mech Eng.* 2018;10:1-13.