

# Exploring Robotic Arm Fabrication: An In-depth Review of Current Trends

Vikas Ranjan<sup>1\*</sup>, Vullingala Dinesh Sai Kumar<sup>2</sup>, Polamarasetti Sasi Kumar<sup>3</sup>,  
Gunupuru Krishna Kanth<sup>4</sup>, Tompa Mohan<sup>5</sup>

## Abstract

*Robotic arms have emerged as indispensable tools across a myriad of industries, revolutionizing manufacturing processes, medical procedures, and even everyday tasks. This comprehensive review explores the recent advancements in robotic arm technology, focusing on key developments in design, control, sensing, and applications. The review begins by examining the evolution of robotic arm design, highlighting innovations in materials, actuators, and kinematic configurations that have enhanced the performance, versatility, and dexterity of robotic arms. It then delves into the advancements in control algorithms and software frameworks, showcasing how adaptive control, machine learning, and artificial intelligence have enabled robotic arms to operate autonomously, learn from experience, and collaborate seamlessly with humans. Furthermore, the review discusses the integration of advanced sensing technologies, including vision systems, tactile sensors, and force feedback mechanisms, which have empowered robotic arms with enhanced perception and interaction capabilities. These sensing capabilities enable robotic arms to adapt to dynamic environments, detect and handle delicate objects, and ensure safe human-robot interaction. Moreover, the review explores the diverse applications of robotic arms across industries such as manufacturing, healthcare, agriculture, and space exploration. It highlights operations and examples of how robotic arms are transforming production processes, enabling minimally invasive surgeries, optimizing agricultural operations, and advancing space exploration missions. Finally, the review identifies emerging trends and future directions in robotic arm technology, including the integration of soft robotics, swarm robotics, and bio-inspired designs. It concludes by emphasizing the transformative potential of robotic arms in addressing societal challenges, enhancing productivity, and shaping the future of automation. Overall, this review provides a comprehensive overview of the recent advancements in robotic arm technology, highlighting their transformative impact on various industries and envisioning their continued evolution towards more capable, adaptable, and intelligent robotic systems.*

**Keywords:** Kinematic configuration, actuators, robot, challenges, evolution

### \*Author for Correspondence

Vikas Ranjan  
E-mail: [Vikasranjan7@gmail.com](mailto:Vikasranjan7@gmail.com)

<sup>1</sup>Assistant Professor, Department of Mechanical Engineering, Baba Institute of Technology and Sciences, Visakhapatnam, Andhra Pradesh, India

<sup>2-5</sup>Student, Department of Mechanical Engineering, Baba Institute of Technology and Sciences, Visakhapatnam, Andhra Pradesh, India

Receiving Date: August 10, 2024

Accepted Date: August 25, 2024

Published Date: September 18, 2024

**Citation:** Vikas Ranjan, Vullingala Dinesh Sai Kumar, Polamarasetti Sasi Kumar, Gunupuru Krishna Kanth, Tompa Mohan. Exploring Robotic Arm Fabrication: An In-depth Review of Current Trends. Journal of Control & Instrumentation. 2024; 15(3): 28–41p.

## INTRODUCTION

A robotic arm is a mechanical device, typically programmable, that is designed to manipulate objects or perform tasks with precision, flexibility, and often in a repetitive manner. It mimics the function of a human arm, consisting of multiple segments (links) connected by joints. These joints allow the arm to move in various directions, such as rotation, extension, and flexion [1]. Robotic arms are commonly used in industrial settings for tasks such as assembly, welding, painting, and material handling. They are also utilized in a wide range of other applications, including medical surgery, space exploration, agriculture, and household chores.

---

Modern robotic arms are often equipped with sensors, cameras, and other technologies to enable advanced functionalities such as object recognition, force feedback, and autonomous operation. They can be controlled manually by an operator or programmed to perform tasks autonomously using computer algorithms or predefined instructions [2].

In addition to their versatility and precision, robotic arms offer several advantages over human labor in various industries. They can operate in hazardous environments, such as those with extreme temperatures, high levels of radiation, or toxic substances, reducing the risk of injury or exposure to workers. Robotic arms can also work continuously without fatigue, leading to increased productivity and efficiency in manufacturing processes. Furthermore, their programmable nature allows for quick reconfiguration and adaptation to different tasks, making them highly flexible and suitable for environments where production needs may change frequently. As technology advances, robotic arms are becoming increasingly sophisticated, with the integration of artificial intelligence and machine learning enabling them to learn from experience and optimize their performance over time. These advancements continue to expand the potential applications of robotic arms across various industries, revolutionizing the way tasks are accomplished and driving innovation in automation [3].

### **NEED OF ROBOTIC ARM**

A machine that resembles a human in both appearance and operation is referred to as a robot. Automation is quickly replacing manual system control in the modern industry in an effort to boost output and provide higher-quality goods. Although they may be used to increase productivity and quality, computer-based solutions are very expensive and difficult to operate with. As a result, automated systems for carrying out industrial operations were quickly adopted. One important industrial operation is moving and picking up objects from one location to another. Automation of pick-and-place operations contributes to increased system performance and efficiency.

The need for robotic arms stems from the desire to automate tasks that are either too repetitive, dangerous, or precise for humans to perform efficiently or safely. Here are some key reasons for the use of robotic arms:

1. *Automation in manufacturing*: Robotic arms are extensively used in manufacturing industries to automate tasks such as assembly, welding, painting, and material handling. They can work continuously without breaks, leading to increased productivity and cost-effectiveness [4].
2. *Precision and accuracy*: Robotic arms can perform highly precise and repetitive tasks with consistency and accuracy, ensuring high-quality output. This is particularly crucial in industries like electronics and pharmaceuticals where even minor errors can have significant consequences.
3. *Enhanced safety*: By taking over tasks that are hazardous for humans, such as working in extreme temperatures, handling toxic materials, or operating in confined spaces, robotic arms help improve workplace safety and reduce the risk of accidents and injuries.
4. *Increased efficiency*: Robotic arms can work at a constant pace without fatigue, leading to improved efficiency and throughput in manufacturing processes. They can also operate 24/7, leading to round-the-clock production capabilities.
5. *Flexibility and adaptability*: Many robotic arms are designed to be easily reprogrammable and can adapt to different tasks and environments. This flexibility makes them suitable for use in various industries and allows manufacturers to quickly reconfigure their production lines in response to changing demands [5].
6. *Space exploration and research*: In environments like space where human presence is limited or not feasible, robotic arms play a crucial role in conducting experiments, collecting samples, and performing maintenance tasks on spacecraft, rovers, and space stations.
7. *Medical applications*: Robotic arms are used in minimally invasive surgery, allowing surgeons to perform complex procedures with greater precision and control, leading to reduced patient trauma, shorter recovery times, and improved surgical outcomes.

Overall, the need for robotic arms arises from the desire to improve efficiency, safety, and productivity across various industries while also enabling advancements in technology and exploration beyond limits.

## LITERATURE REVIEW

Krishnaraj Rao and colleagues [1] suggested using machine learning to show how to develop and operate an automated robotic arm. For item identification, detection, and traversal, the work employs a machine learning approach that is combined with the Tensor Flow package to produce more precise and reliable results [1]. Shah and Pandey [2] created a flexible, inexpensive robotic arm that may be used in any industry to solve the issue of manufacturing speed in order to meet client demands. Usman [3] reported on the design and fabrication of a programmable autonomous robotic arm with five degrees of freedom. The focus of Polygerinos et al. [6] was on elastomeric robots that are inherently soft and propelled by fluidic pressurization. A particularly appealing class of soft actuators powered by pressurized fluids was reviewed by Gorissen et al. [5]. Recently, these actuators have become more popular due to a combination of market pull from applications and technological push from new manufacturing technologies and improved modelling tools. They provide a summary of the many advanced soft actuator configurations, including information on how they are made, designed, and used [5]. A unique soft inflatable arm for telepresence robots has been proposed by Qi et al. [7]. The newly suggested arm structure is incredibly light, weighing only roughly 50 g, and was made possible by a highly popular and inexpensive inflatable polymer [7]. Preliminary findings on the simultaneous control of position and stiffness for a soft robot operated by pneumatics were presented by Gillespie et al. [8]. They demonstrate that we can increase our average rise time by up to 137%, settling time by 119%, and overshoot by 853% by using the pressure in our soft robot actuation chambers as state variables. The user can now concurrently manage stiffness and joint position in addition to these enhancements. The use of enhanced dynamic soft robot models in conjunction with model predictive control operating at 300 Hz is what improves performance [8]. The design of a novel long-range robotic arm built on an inflatable construction was presented by Voisembert et al. [9]. Improved huge payload-to-weight ratios, safe collisions, and inspection in regions off-limits to humans, including nuclear reactors, are among the potential uses for inflatable robotics [9]. Many of the issues related to creating soft, pneumatically-actuated, inflated robots that require good control were identified by Hyatt et al. [10], who also suggested a method for resolving a portion of these issues.

## WORKING MECHANISM

The work of the project involves the integration of mechanical and electrical components to create an automated robotic manipulator (ARM). Here is a step-by-step overview of how the project operates:

The robotic arm is designed with mechanical components that allow for a wide range of motion, The placement of servo motors strategically allows for rotational movement, enhancing the arm's flexibility.

The heart of the project is the electrical control unit. Arduino Uno microcontroller as a central processing unit. It receives commands and translates them into electrical signals for the servo motors for moment of arm.

The mechanical design, coupled with the electrical control, allows the robotic arm to move in all directions, covering a complete 360-degree spectrum. The primary function of the ARM system is pick-and-place operations, where it can grasp, lift, and release objects in a controlled manner. The user can specify the location and movement required for the arm to perform these tasks.

Detail description about individual components which is being used in the arm mechanism:

- Aurdino Uno
- Servo motors
- Servo motor driver

- Bluetooth
- Buck converter
- Jumper wires
- Bread board
- Lithium-polymer (LiPo) battery

## COMPONENTS AND THEIR FUNCTIONS

### Arduino Uno

Arduino Uno is a popular microcontroller board used in many electronic projects. It is based on the ATmega328P microcontroller and has digital input/output pins, analog inputs, a USB connection, a power jack, and a reset button. Arduino Uno is shown in Figure 1.

The digital pins can be used for tasks like turning an LED on or off, reading a sensor, or controlling other devices. The analog pins can read analog signals from sensors like light sensors, temperature sensors, etc. Arduino Uno can be programmed using the Arduino IDE (integrated development environment) where you can write code in C/C++ to control the board's functions. It is widely used in DIY (do it yourself) projects, robotics, automation, and many other applications due to its ease of use and versatility.

### Servo Motor Driver

A servo motor driver is a device that is used to control the movement and position of a servo motor. It acts as an interface between the microcontroller or control system and the servo motor. The servo motor driver receives signals from the controller and amplifies them to provide the necessary power to the servo motor for precise movement. A servo motor driver is shown in Figure 2.

Servo motor drivers typically have features like pulse-width modulation (PWM) input, which is a common way to control servo motors, as well as other control options such as position control, speed control, and torque control. They help in converting the control signals from the microcontroller into the appropriate signals required by the servo motor to move to the desired position accurately.

### Servo Motor

Servo motors are precise motors used for accurate position control in robotics and automation. They consist of a DC motor, gearbox, and control circuit, allowing them to move to specific angles based on PWM signals. These motors are popular in projects like remote controlled vehicles, robotic arms, and drones due to their high torque, responsiveness, and reliability. Servo motors come in various sizes, torque ratings, and can be continuous rotation or limited angle. They are efficient, quiet, and have smooth operation, making them ideal for tasks requiring precision. A servo motor shown in Figure 3. With feedback mechanisms for accuracy, servo motors are easy to control, affordable, and commonly interfaced with microcontrollers like Arduino. Overall, servo motors are versatile components essential in many DIY projects and various industries.

### Bluetooth

The HC-05 Bluetooth module is a popular Bluetooth module used for wireless communication in electronic projects. It is commonly used to enable Bluetooth connectivity between devices like Arduino boards and smartphones or other Bluetooth-enabled devices. A Bluetooth module is shown in Figure 4. The HC-05 module allows for serial communication over Bluetooth, making it easy to establish a wireless connection between devices. It operates on the Bluetooth 2.0 standard and supports a range of up to 10 meters. The HC-05 module can be configured as a master or slave device, depending on the application requirements. It is widely used in projects like home automation, robotics, and remote-control systems where wireless communication is needed. The module can be easily interfaced with microcontrollers like Arduino for seamless integration into various projects.

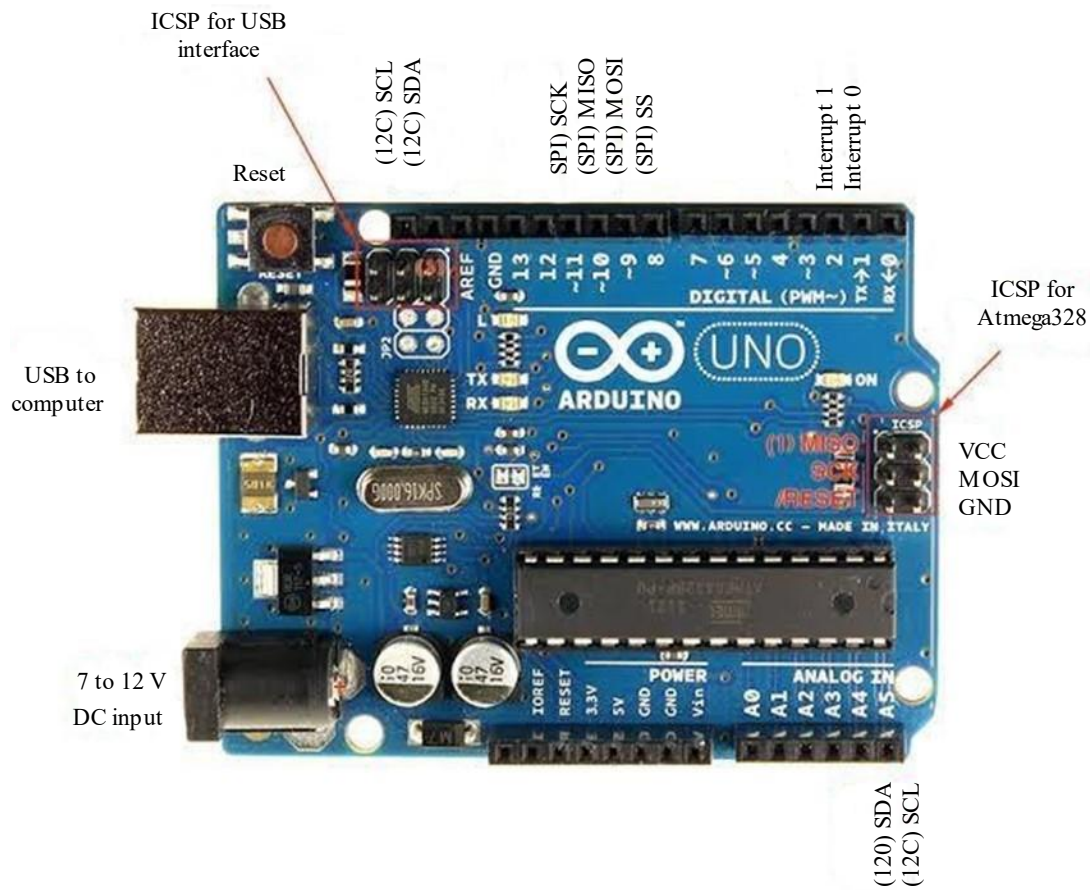

Figure 1. Arduino Uno.



Figure 2. Servo motor driver.



**Figure 3.** Servo motor.

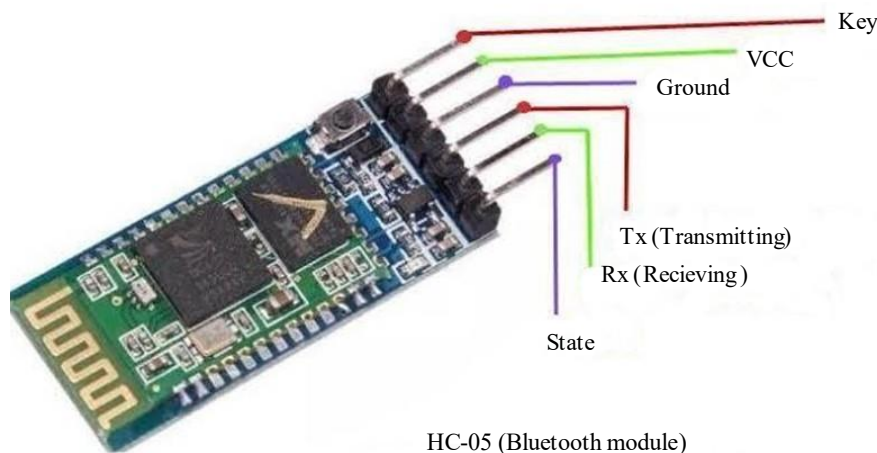

HC-05 (Bluetooth module)

**Figure 4.** Bluetooth module.

### Buck Converter

In a robotic arm, a buck converter serves the function of regulating the voltage supplied to various components of the arm, typically motors and actuators, in order to efficiently manage power consumption and control the speed and torque of these components. Here is how a buck converter functions within the context of a robotic arm. Robotic arms often use DC motors or servo motors for actuation. These motors typically require a specific voltage to operate efficiently. A buck converter is shown in Figure 5. A buck converter takes a higher input voltage, commonly from a power source such as a battery or an external power supply, and converts it to a lower, regulated voltage suitable for the motors. Buck converters are known for their high efficiency in converting one voltage level to another. By stepping down the voltage using PWM techniques, a buck converter can minimize power losses and heat dissipation, making it an energy-efficient solution for powering the motors in a robotic arm. Controlling the voltage supplied to the motors allows precise control over their speed and torque. By adjusting the duty cycle of the PWM signal generated by the buck converter, the effective voltage applied to the motors can be varied, thereby controlling their rotational speed and the amount of torque they produce. Buck converters often include features such as overvoltage protection, undervoltage protection, and current limiting to protect the motors and other components of the robotic arm from damage due to electrical faults or sudden changes in load conditions. Buck converters can be designed to be compact and lightweight, making them suitable for integration into the limited space available within the structure of a robotic arm. Their modular design also allows for easy scalability and integration with other electronic components.

### Jumper Wires

In a robotic arm, a jumper wire serves as a means of electrical connection between components or circuits. The function of a jumper wire in a robotic arm can vary depending on the specific design and configuration of the arm, but here are some common functions it may serve. Jumper wires can be used to route electrical signals or power between different components or sections of the robotic arm's control system. This allows for the creation of specific electrical pathways to ensure proper operation of the arm. In cases where there are breaks or interruptions in a circuit, jumper wires can be used to bridge these gaps and restore the flow of electrical signals. This ensures that control signals, sensor data, or power are transmitted effectively throughout the robotic arm's system. Jumper wires can be employed as a temporary or permanent solution to address faults or defects in wiring. Jumper wires are shown in Figure 6. For example, if there is a damaged wire or connector in the arm's electrical system, a jumper wire can be used to bypass the faulty component and restore functionality. Jumper wires can be used during prototyping, testing, or modifications of the robotic arm's electronics. They allow for flexibility in experimenting with different configurations or adding new features without the need for extensive rewiring. Jumper wires may also be used to connect the robotic arm to external devices or peripherals, such as sensors, actuators, or communication modules. This facilitates integration with other systems or enables additional functionalities. Overall, jumper wires play a crucial role in ensuring proper electrical connectivity and functionality within a robotic arm's control system. They provide a versatile and efficient way to establish connections, troubleshoot issues, and customize the arm's electronics to meet specific requirements.



**Figure 5.** Buck converter.



**Figure 6.** Jumper wires.

---

## **Breadboard**

In the context of a robotic arm, a breadboard typically serves as a prototyping platform for connecting and testing electronic components such as sensors, actuators, microcontrollers, and other modules before integrating them into the final circuitry of the robotic arm. The function of a breadboard in a robotic arm can be included. Breadboards allow engineers and roboticists to quickly prototype and test different electronic circuits and components without the need for soldering. A breadboard is shown in Figure 7. This is particularly useful during the development phase of the robotic arm when experimenting with various sensors, motors, and control systems. Breadboard provides a convenient way to connect and interface various electronic components, such as sensors for detecting position, force, or proximity, as well as actuators like motors or servos for controlling movement. Breadboard offers flexibility in designing and modifying circuits by allowing components to be easily inserted, removed, and repositioned. This flexibility is essential for iterating on the design of the robotic arm and adjusting based on testing results. Breadboards facilitate troubleshooting of electronic circuits by enabling easy access to individual components and connections. Engineers can visually inspect the circuit layout, identify potential issues, and make necessary modifications to ensure proper functionality. Breadboards are commonly used in educational settings to teach students about electronics, circuit design, and prototyping. In the context of a robotic arm project, breadboards can help students understand the electronic components and principals involved in building and controlling robotic systems. During the development phase of a robotic arm, the design of the electronic circuitry may undergo multiple revisions. Breadboard provides a means to quickly assemble and test temporary circuits before finalizing the design and implementing it on a more permanent circuit board. Overall, the function of a breadboard in a robotic arm project is to facilitate the rapid prototyping, testing, and iteration of electronic circuits and components, ultimately contributing to the development of a functional and reliable robotic arm system. Once the design is finalized and tested, the circuitry can be transitioned from the breadboard to custom PCBs (printed circuit boards) for integration into the robotic arm.

## **Lithium-polymer Battery**

Lithium-polymer (LiPo) batteries can serve several important functions in a robotic arm. Lithium polymer batteries are lightweight and have a high energy density, making them an ideal power source for mobile robotic applications. In a robotic arm, LiPo batteries can provide the necessary electrical energy to drive motors, actuators, sensors, and control systems. Robotic arms often need to be mobile and portable, especially in applications such as field robotics, search and rescue operations, or unmanned aerial vehicles (UAVs). LiPo batteries offer a compact and lightweight power solution, allowing the robotic arm to operate autonomously without being tethered to a power source. LiPo batteries can store a significant amount of energy relative to their size and weight, enabling the robotic arm to perform tasks for extended periods before needing recharging or replacement. This is particularly important in applications where continuous operation is required, such as in industrial automation or surveillance. A lithium-polymer battery is shown in Figure 8. LiPo batteries typically provide a stable voltage output, which is essential for ensuring consistent performance of the robotic arm's electrical components. Voltage regulation circuits can be integrated into the robotic arm's power management system to maintain a steady supply of power to motors, controllers, and other electronics. LiPo batteries are rechargeable, allowing them to be reused multiple times without significant degradation in performance. This is advantageous for robotic arms that undergo frequent use or operate in remote locations where access to power outlets may be limited. Modern LiPo batteries often include built-in safety features such as overcharge protection, over-discharge protection, and short circuit protection. These safety mechanisms help prevent damage to the battery and ensure safe operation of the robotic arm, reducing the risk of accidents or malfunctions. Overall, LiPo batteries play a crucial role in providing power, portability, and reliability to robotic arms, enabling them to perform a wide range of tasks efficiently and autonomously.

## **CHALLENGES AND FUTURE DIRECTIONS**

This sections deals with addressing challenges such as scalability, adaptability, reliability, and cost-effectiveness.

---

Ethical and societal implications of widespread robotic arm deployment, including job displacement and safety concerns. Potential future directions in robotic arm research and development, including soft robotics, bioinspired designs, and swarm robotics.

A comprehensive literature review on robotic arms would draw upon a diverse range of academic journals, conference proceedings, books, and technical reports from disciplines such as robotics, mechanical engineering, computer science, and biomedical engineering. Evolution in the design of robotic arm over decades is shown in Figure 9.



**Figure 7.** Breadboard.



**Figure 8.** Lithium-polymer battery.

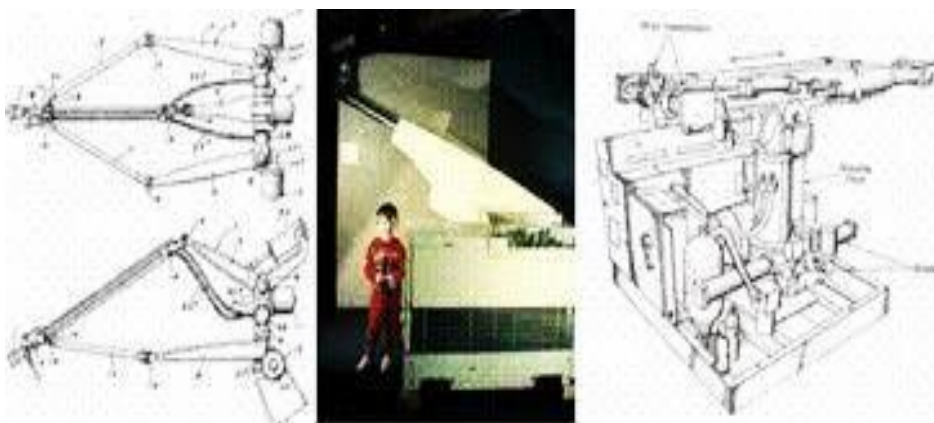

**Figure 9.** Evolution in the design of robotic arm over decades.

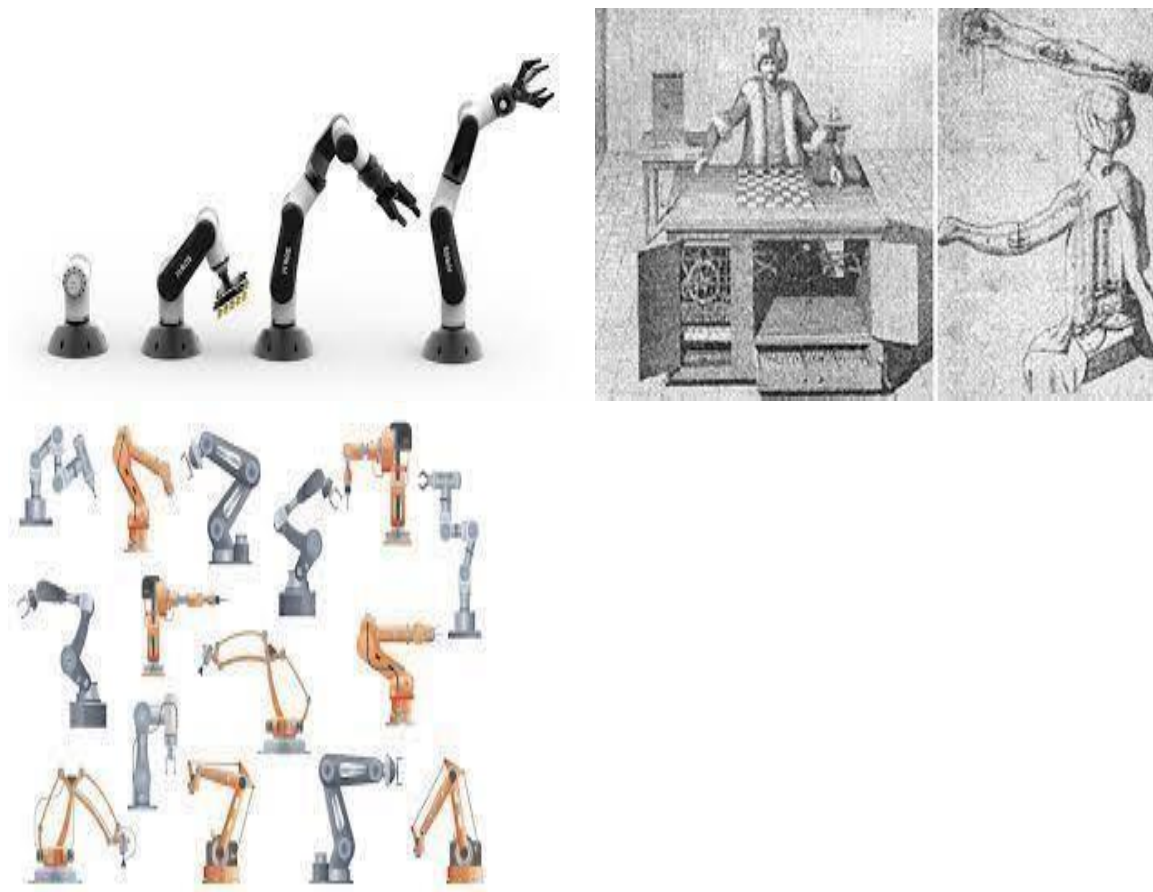

**Figure 10.** Fabrication of robotic arm.

The fabrication of a robotic arm involves several stages, each requiring a combination of mechanical, electrical, and sometimes software engineering. Here is an overview of the typical steps involved. Fabrication of robotic arm is shown in Figure 10.

### **Design Phase**

This phase involves conceptualizing the robotic arm's specifications, including its size, shape, range of motion, payload capacity, and intended applications. Engineers use computer-aided design (CAD) software to create detailed 3D models of the robotic arm, taking into account factors such as stress analysis, material selection, and assembly considerations.

### **Component Selection**

Once the design is finalized, engineers select the necessary components for the robotic arm, such as motors, gears, actuators, sensors, and structural materials. These components are chosen based on factors such as performance requirements, cost-effectiveness, and compatibility with the design specifications.

### **Manufacturing**

The components are fabricated using various manufacturing processes, including machining, casting, 3D printing, and molding. Precision is crucial during this stage to ensure that the parts meet the required tolerances and specifications.

### **Assembly**

The fabricated components are assembled according to the design specifications. This involves connecting the various parts together using fasteners, adhesives, and mechanical joints. During assembly, engineers must ensure proper alignment, fit, and functionality of each component.

### **Electrical Integration**

Electrical components such as motors, sensors, and controllers are integrated into the robotic arm assembly. This includes wiring, soldering, and connecting electronic components to power sources and control interfaces.

### **Programming and Calibration**

Once the mechanical and electrical components are assembled, the robotic arm is programmed to perform specific tasks. This programming may involve writing code for the arm's control system, implementing algorithms for motion planning and trajectory generation, and integrating sensor feedback for closed-loop control. Calibration is also performed to ensure the accuracy and precision of the arm's movements.

### **Testing and Iteration**

The fabricated robotic arm undergoes rigorous testing to evaluate its performance, reliability, and safety. This may involve conducting functional tests, stress tests, and real-world simulations to validate the arm's capabilities and identify any design flaws or performance issues. Based on the test results, iterative improvements may be made to refine the design and optimize the arm's performance.

### **Deployment and Maintenance**

Once the robotic arm is successfully fabricated and tested, it is deployed for its intended applications. Regular maintenance and upkeep are essential to ensure the arm's continued operation and longevity, including monitoring for wear and tear, replacing worn-out components, and updating software as needed.

Overall, the fabrication of a robotic arm requires interdisciplinary collaboration between mechanical engineers, electrical engineers, software developers, and other experts to design, build, and deploy a functional and reliable robotic system.

### **Maintenance**

Maintenance of a robotic arm is essential to ensure its optimal performance, reliability, and longevity. Here are some key aspects of robotic arm maintenance:

1. *Regular inspection:* Conduct routine visual inspections of the robotic arm components, including mechanical parts, electrical connections, and sensors. Look for signs of wear, damage, or misalignment that may affect the arm's operation.
2. *Cleaning:* Keep the robotic arm clean and free from debris, dust, or foreign particles that could interfere with its movement or sensors. Use appropriate cleaning methods and materials to avoid damaging sensitive components.
3. *Lubrication:* Lubricate moving parts and joints as recommended by the manufacturer to reduce friction, prevent wear, and ensure smooth operation. Use lubricants that are compatible with the materials and environments in which the robotic arm operates.
4. *Tightening and adjustment:* Periodically check and tighten fasteners, bolts, and mechanical connections to prevent loosening or detachment during operation. Perform any necessary adjustments to maintain proper alignment and functionality of the arm.
5. *Calibration:* Regularly calibrate the robotic arm to ensure accuracy, precision, and repeatability in its movements. This may involve adjusting motor parameters, fine-tuning control algorithms, and verifying sensor readings.
6. *Software updates:* Keep the robotic arm's control software up to date with the latest firmware and software patches provided by the manufacturer. Software updates may include bug fixes, performance enhancements, and new features that improve the arm's functionality.
7. *Backup and data management:* Implement a backup system to store important data, such as configuration settings, calibration parameters, and motion trajectories. Regularly back up this data to prevent loss in case of system failures or hardware malfunctions.

8. *Training and documentation:* Train personnel responsible for maintaining the robotic arm on proper maintenance procedures, safety protocols, and troubleshooting techniques. Keep comprehensive documentation, including maintenance schedules, logs, and manuals, readily available for reference.
9. *Safety checks:* Conduct safety checks to ensure that the robotic arm complies with relevant safety standards and regulations. Inspect safety features such as emergency stop buttons, protective covers, and collision detection systems to prevent accidents and injuries.
10. *Professional service:* When necessary, engage qualified technicians or service professionals to perform specialized maintenance tasks, repairs, or upgrades. Follow the manufacturer's recommendations for service intervals and procedures to maintain warranty coverage and ensure the continued reliability of the robotic arm.

By following these maintenance practices, you can maximize the performance, reliability, and lifespan of your robotic arm, minimizing downtime and ensuring consistent operation in various industrial and commercial applications.

### Applications

Robotic arms find applications across a wide range of industries and domains due to their versatility, precision, and ability to perform repetitive tasks with consistency. Here are some common applications of robotic arms:

1. *Manufacturing and assembly:* Robotic arms are extensively used in manufacturing industries for tasks such as assembly, welding, painting, pick-and-place operations, and material handling. They can work continuously with high speed and precision, leading to increased productivity and efficiency on production lines.
2. *Automotive industry:* Robotic arms play a crucial role in automobile manufacturing, performing tasks such as welding car bodies, assembling components, painting vehicles, and handling heavy materials. They contribute to streamlining production processes, improving quality control, and reducing labor costs.
3. *Medical surgery:* In the field of medicine, robotic arms are employed in minimally invasive surgeries such as laparoscopic procedures and robot-assisted surgeries. Surgeons use robotic arms equipped with miniature instruments and cameras to perform precise movements with enhanced dexterity, leading to improved surgical outcomes and reduced patient trauma.
4. *Space exploration:* Robotic arms are used in space missions for various tasks, including capturing and docking spacecraft, deploying payloads, conducting repairs and maintenance on satellites and space stations, and collecting samples from celestial bodies. They enable astronauts to perform tasks safely and efficiently in the harsh environment of space.
5. *Logistics and warehousing:* In logistics and warehousing operations, robotic arms are utilized for tasks such as palletizing, sorting, packing, and stacking goods in warehouses and distribution centers. They enhance order fulfillment processes, optimize inventory management, and reduce manual labor in logistics operations.
6. *Food processing:* Robotic arms are employed in the food industry for tasks such as packaging, sorting, slicing, and handling food products. They ensure consistent quality and hygiene standards, improve food safety, and increase productivity in food processing facilities.
7. *Agriculture:* In agriculture, robotic arms are used for tasks such as planting, harvesting, pruning, and sorting crops. They help automate labor-intensive agricultural processes, optimize resource usage, and increase yields in farming operations.
8. *Construction and demolition:* Robotic arms are utilized in construction and demolition projects for tasks such as bricklaying, concrete pouring, demolition, and debris removal. They improve safety, speed up construction processes, and enable precise execution of complex building tasks.
9. *Entertainment and gaming:* Robotic arms are incorporated into amusement park rides, simulators, and interactive exhibits for entertainment purposes. They provide thrilling experiences, realistic simulations, and immersive gameplay in entertainment venues and gaming centers.

10. *Research and education:* Robotic arms are used in research laboratories and educational institutions for experimentation, prototyping, and teaching purposes. They enable students and researchers to explore robotics concepts, develop new technologies, and gain practical experience in robotics engineering and programming.

These are just a few examples of the diverse applications of robotic arms, highlighting their importance and impact across various industries and domains. As technology continues to advance, the potential applications of robotic arms are expected to expand further, driving innovation and automation in numerous fields.

## **FUTURE SCOPE**

The future scope of robotic arms is broad and promising, with advancements expected in various areas of technology, application, and research. Some key aspects of the future scope of robotic arms include the following.

### **Advanced Materials and Manufacturing Techniques**

Future robotic arms are likely to benefit from the use of advanced materials such as carbon fibre composites, shape memory alloys, and 3D-printed components. These materials offer advantages such as reduced weight, increased strength, and enhanced flexibility, allowing for more agile and efficient robotic arm designs.

The development of soft robotics and bio-inspired designs is opening up new possibilities for robotic arm functionality and versatility. Soft robotic actuators and grippers mimic the flexibility and dexterity of biological limbs, enabling safer interactions with humans and delicate objects, as well as enhanced adaptability to complex environments. Integration of artificial intelligence and machine learning techniques into robotic arm control systems will enable more autonomous and adaptive behavior. AI algorithms can optimize motion planning, trajectory generation, and task execution, while machine learning algorithms can learn from experience to improve performance, adapt to changing conditions, and handle uncertainty more effectively. The future of robotic arms involves closer collaboration between humans and robots in shared workspaces. Collaborative robotic arms equipped with advanced sensors and safety features will be capable of working alongside humans more safely and efficiently, enhancing productivity in manufacturing, healthcare, and other industries. Advances in miniaturization and micro-robotics will enable the development of smaller, more agile robotic arms suitable for applications in fields such as medicine, electronics manufacturing, and nanotechnology. These miniature robotic arms could perform tasks with unprecedented precision at the micro scale, opening up new possibilities for manipulation and assembly in confined spaces. Future robotic arms may operate as part of larger multi-agent systems or swarms, collaborating with other robots to perform complex tasks collectively. Swarm robotics enables distributed coordination and task partitioning among multiple robotic arms, leading to enhanced scalability, fault tolerance, and adaptability in dynamic environments.

*Sustainability and environmental applications:* Robotic arms will play a role in addressing global challenges such as environmental sustainability and climate change. In sectors like agriculture and renewable energy, robotic arms can be used for precision farming, environmental monitoring, and maintenance of green technologies, contributing to more efficient resource utilization and reduced environmental impact. As humanity expands its presence in space, robotic arms will be indispensable for activities such as satellite servicing, planetary exploration, and construction of space habitats. Future robotic arms designed for space applications will need to withstand harsh environmental conditions, operate autonomously over long distances, and adapt to low-gravity environments.

Overall, the future scope of robotic arms is characterized by innovation, integration, and collaboration across multiple disciplines, paving the way for transformative advancements in technology, industry, and society.

## CONCLUSION

In conclusion, robotic arms represent a pivotal advancement in automation technology, offering unprecedented capabilities for precision manipulation, task automation, and human augmentation across various industries and applications. Throughout their evolution, robotic arms have transformed manufacturing processes, medical procedures, space exploration, and numerous other fields, revolutionizing the way tasks are performed and expanding the boundaries of what is possible. The versatility and adaptability of robotic arms continue to drive innovation and research, leading to advancements in materials, control systems, artificial intelligence, and human-robot interaction. From the integration of advanced materials and soft robotics to the emergence of collaborative and autonomous systems, the future of robotic arms holds immense promise for enhancing productivity, safety, and efficiency in diverse domains. As robotic arms become more sophisticated and accessible, they will play an increasingly vital role in addressing global challenges such as sustainability, healthcare, and space exploration. Moreover, the continued convergence of robotics with other emerging technologies, such as 5G connectivity, edge computing, and augmented reality, will further expand the capabilities and applications of robotic arms, unlocking new opportunities for innovation and societal impact. In summary, robotic arms represent a cornerstone of the ongoing technological revolution, offering boundless potential to shape the future of work, industry, and human-machine interaction. With ongoing research, development, and collaboration, robotic arms will continue to evolve, empower, and inspire as we embark on the journey towards a more automated, interconnected, and resilient world.

## REFERENCES

1. Krishnaraj Rao NS, Avinash NJ, Rama Moorthy H, Karthik K, Rao S, Santosh S. An automated robotic arm: a machine learning approach. arXiv. arXiv:2201.07882. Available at <https://arxiv.org/abs/2201.07882>
2. Shah R, Pandey AB. Concept for automated sorting robotic arm. *Procedia Manuf.* 2018; 20: 400–405.
3. Usman Z. Design and fabrication of a programmable 5-DOF autonomous robotic arm. In: *Proceedings of the 6th WSEAS International Conference on Systems Theory & Scientific Computation*, Elounda, Greece, August 21–23, 2006. pp. 167–173.
4. Gaiser I, Wiegand R, Ivlev O, Andrés A, Breitwieser H, Schulz S, Bretthauer G. Compliant robotics and automation with flexible fluidic actuators and inflatable structures. In: Berselli G, Verthey R, Vassura G, editors. *Smart Actuation and Sensing Systems – Recent Advances and Future Challenges*. London, UK: IntechOpen; 2012. pp. 567–608. doi: 10.5772/51866.
5. Gorissen B, Reynaerts D, Konishi S, Yoshida K, Kim J-W, De Volder M. Elastic inflatable actuators for soft robotic applications *Adv Mater.* 2017; 29 (43): 1604977.
6. Polygerinos P, Correll N, Morin SA, Mosadegh B, Onal CD, Petersen K, Cianchetti M, Tolley MT, Shepherd RF. Soft robotics: review of fluid-driven intrinsically soft devices; manufacturing, sensing, control, and applications in human-robot interaction. *Adv Eng Mater.* 2017; 19 (12): 1700016. doi: 10.1002/adem.201700016.
7. Qi R, Khajepour A, Melek WW, Lam TL, Xu Y. Design, kinematics, and control of a multijoint soft inflatable arm for human-safe interaction. *IEEE Trans Robotics.* 2017; 33 (3): 594–609. doi: 10.1109/TRO.2016.2647231.
8. Gillespie MT, Best CM, Killpack MD. Simultaneous position and stiffness control for an inflatable soft robot. In: *2016 IEEE International Conference on Robotics and Automation (ICRA)*, Stockholm, Sweden, March 16–21, 2016. pp. 1095–1101. doi: 10.1109/ICRA.2016.7487240.
9. Voisembert S, Mechbal N, Riwan A, Aoussat A. Design of a novel long-range inflatable robotic arm: manufacturing and numerical evaluation of the joints and actuation. *J Mechanisms Robotics.* 2013; 5 (4): 045001.
10. Hyatt P, Kraus D, Sherrod V, Rupert L, Day N, Killpack MD. Configuration estimation for accurate position control of large-scale soft robots. *IEEE/ASME Trans Mechatronics.* 2019; 24 (1): 88–99. doi: 10.1109/TMECH.2018.2878228.